



Compressor Nebulizer

Model UN-019

Instruction Manual
Original

ENGLISH

Manuel d'instructions
Traduction

FRANÇAIS

Manual de Instrucciones
Traducción

ESPAÑOL

Manuale di Istruzioni
Traduzione

ITALIANO

Bedienungsanleitung
Übersetzung

DEUTSCH

CONTENTS

1. DEAR CUSTOMERS	Page 2
2. PRELIMINARY REMARKS	Page 2
3. SYMBOLS.....	Page 2
4. IMPORTANT SAFEGUARDS	Page 3
5. INTRODUCTION.....	Page 5
6. SPECIFICATIONS	Page 5
7. PARTS IDENTIFICATION.....	Page 6
8. OPERATING INSTRUCTIONS	Page 7
9. CLEANING.....	Page 8
10. MAINTENANCE.....	Page 8
11. TROUBLESHOOTING	Page 9
12. TECHNICAL DATA	Page 10
13. EMD TECHNICAL DATA	Page 10
14. CORRECT DISPOSAL OF THIS PRODUCT (WASTE ELECTRICAL & ELECTRONIC EQUIPMENT).....	Page 13

1. DEAR CUSTOMERS

Thank you for purchasing the UN-019 Compressor Nebulizer.

This device is a compact medical device designed to deliver the medication prescribed by your doctor.

The compressor creates a stream of air that travels through the clear tubing to the nebulizer which generates a mist of medicinal particles small enough to reach the furthest parts of your lungs to provide maximum benefit for the treatment of asthma, allergies and other respiratory disorders.











This device should be used only as directed. Do not use this device for anything other than as prescribed by your doctor.

Before use, read this instruction manual thoroughly.

2. PRELIMINARY REMARKS

This device conforms to the European Directive 93/42 EEC for Medical Products. This is proved the CE conformity marking CE1639. (1639: The identification number of the Notified Body.)

3. SYMBOLS

Symbols	Meaning
	Caution Attention or Consult accompanying documents
	Type BF Equipment
	Alternating Current
	Double Insulation
	Indoor use only
	Manufacturer
	Refer to instruction manual
	WEEE label
	EU-representative
	EC directive medical device label

4. IMPORTANT SAFEGUARDS

CAUTION:

1. Federal Law restricts the sale or use of this device to an order by a physician.
2. Follow the instructions of your physician when operating this device.
3. This device is a nebulizer for the inhalation of medical aerosols and is suitable for solutions used by children. Use only the type and amount of medication prescribed by the patient's doctor.
4. This device is intended for aerosol therapy only. Any other use is not recommended.
5. Do not twist the air tube during operation.
6. Do not pour more than 6ml of solution into the device.

DANGER: Risk of electrocution.

7. Always disconnect the power cord from the electrical outlet immediately after using.
8. Do not use while bathing.
9. Do not place or store the unit where it can fall or be pulled into a tub or sink.
10. Do not place or drop the device into water or other liquid.
11. Do not reach for a product that has fallen into water. Disconnect the power cord from the electrical outlet immediately.

 WARNING: Risk of burns, electrocution, fire or injury

1. Electrical Shock Hazard: Do not remove the cabinet or open the cover.
2. Disconnect the power cord from the electrical outlet before cleaning or servicing.
3. Do not place this device near hot, sparking or burning objects.
4. Do not use oil or grease on or near this device.
5. Turn the unit off when it is not in use.
6. Keep the cord away from HEATED or HOT surfaces.
7. NEVER drop or insert any object into any opening.
8. NEVER block the air openings of the product or place it on a soft surface, such as a bed or couch, where the air openings may be blocked.
9. Avoid operating in wet or damp locations.
10. Disconnect the power cord from the electrical outlet before filling the nebulizer cup.
11. When using this device near TVs, microwave ovens, pulse telephones, X-rays, or other strong electric field, there may be electrical interference. It is recommended to be far away from these devices when using this device.

 WARNING: Risk of infection

1. This device is intended for both adult and pediatric patient use.
2. Cleaning of the device is recommended after each aerosol treatment. Disinfecting is recommended once a day. Please follow cleaning and disinfecting instructions in this manual.

This device is not suitable for use in anesthetics breathing systems.

This device is not suitable for solutions in suspension or high viscosity liquids. In such cases information should be sought from the drug supplier.

5. INTRODUCTION

This compressor nebulizer is designed to deliver a prescribed medication solution to treat patient respiratory disorders, such as asthma, allergies and bronchitis. The device converts the medication solution into an aerosolized mist which is inhaled by the patient through the mouthpiece or nosepiece or mask. Read this manual thoroughly before using the device and store it for future reference.

6. SPECIFICATIONS

Electrical Requirements	230 V / 50 Hz
Power Consumption	Below 60 W
Rated Current	Below 0.70 A
Dimensions	Length 250mm × Width 118mm × Height 175mm
Weight	1.4kg(3.09lbs)
Sound Pressure Level	55 dBA
Max. Compression Pressure	35 psi to 50 psi (241 kPa to 345 kPa)
Neb. Operating Pressure	9-16 psi (62 kPa to 110 kPa)
Liter Flow Range	5-8 L/min
Average Nebulization Rate:	Approx. 0.33 ml/min (6 ml medicine can be nebulized within 18 minutes)
Maximum nebulizer solution capacity	6 ml
Maximum residual medicine volume	0.5 ml
Particle size (MMAD)	Approximately 3 µm
Operating Temperature/Humidity	+10°C to + 40°C, 30% RH to 85% RH
Storage/Transport Temperature Range/ Humidity	- 20°C to + 70°C, 10% RH to 95% RH
Operating and Storage/Transport Atmospheric Pressure	700 hPa to 1,060 hPa

Protection against electric shock



- Classified as Type



- Type BF applied parts: Mouthpiece, nosepiece, masks

Degree of safety in the presence of flammable anesthetics or oxygen —

No AP/APG (not suitable for use in the presence of flammable anesthetics or oxygen)

Mode of operation — Continuous

IP21 — Protection against harmful ingress of water is Ordinary.





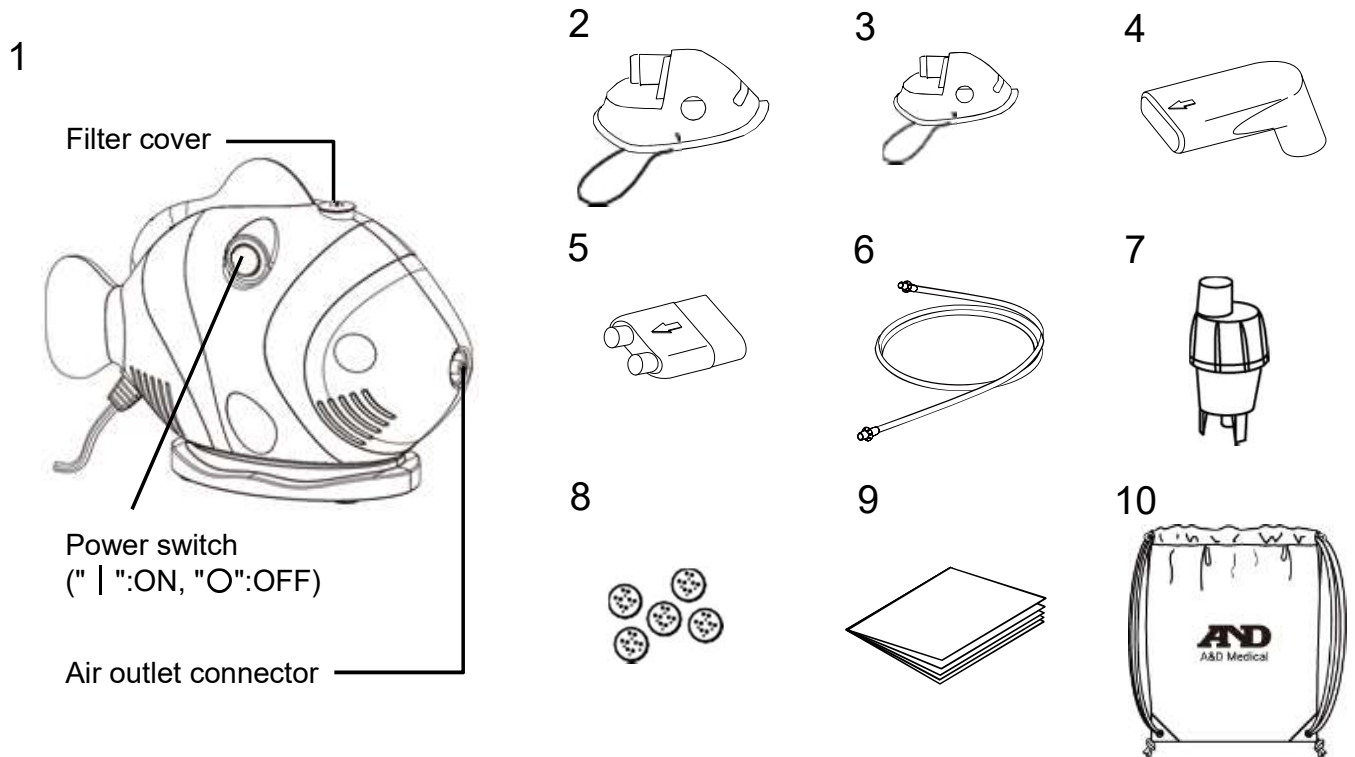

7. PARTS IDENTIFICATION

1. Main unit
2. Adult mask
3. Child mask
4. Mouthpiece
5. Nosepiece
6. Air tube
7. Nebulizer cup
8. Air filters
9. Instruction manual
10. Carrying pouch

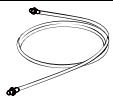

(Plug shape) C-plug: UN-019A-EC1B, BF-plug: UN-019A-EC2B

Replacement parts list

Appearance	Part name	Part code	Qty	Material
	Adult mask	UNB-014A-01EC	1	PVC
	Child mask	UNB-014A-02EC	1	PVC
	Air tube	UNB-014A-03EC	1	PVC
	Air filter	UNB-014A-04EC	5	urethane sponge
	Nebulizer cup	UNB-014A-05EC	1	PP, SAN
	Mouthpiece + Nosepiece	UNB-014A-11EC	1	PP

8. OPERATING INSTRUCTIONS

1. Place the device on a stable, sturdy and flat surface so that the device can be easily reached when you are seated.
2. Make sure that the device is in the "Off" (O) position by pressing on the upper side of switch.
3. Plug power cord into a wall outlet.
4. Connect one end of the air tube into the air outlet connector on the device.
5. Add the prescribed solution through the opening on the cup using an eye dropper or pre-measured dose container.
The "6cc" marking on the nebulizer cup is the maximum level.
Medication cannot be filled beyond the maximum level.
6. Insert the mouthpiece into the top of the nebulizer cup.
If nosepiece is used, insert it into the mouthpiece.
If a mask is used, connect the bottom of the mask to the top of the nebulizer cup.
7. Connect another end of the air tube to nebulizer air inlet connector on the bottom of the nebulizer cup.
8. Turn the power on to start the unit.
9. Initiate the treatment by placing the mouthpiece between the teeth.
Inhale through the mouthpiece and exhale through your nose.
If nosepiece is used, inhale through the nosepiece and exhale your mouth.
10. If a mask is used, place the mask over the mouth and nose.

9. CLEANING

1. Turn the power off and unplug from the wall outlet.
2. Remove the air tube from the air inlet connectors.
3. **TO CLEAN:** Remove the mouthpiece, nosepiece, mask, and disassemble the nebulizer cup (cup, cap, and baffle), and wash these items in hot water with dish-washing detergent. Rinse these items thoroughly to remove the detergent and air dry.
4. **TO DISINFECT:** Mix one part of white vinegar with 3 parts hot water in a clean container. Submerge mouthpiece, nosepiece, mask, and parts of nebulizer cup for half an hour in the solution. Remove from solution and let air dry.
5. There is no need to clean the tube. If necessary wipe the surface regularly.

Note:

- Replace the nebulizer accessories including adult mask, child mask, mouthpiece, nosepiece, nebulizer cup, Air tube after using 6 months.
- Replace the filter every 30 days or if the filter turns grey.

 **CAUTION: The device must be changed if it becomes clogged.**

 **CAUTION: The device and accessories must not be boiled.**

10. MAINTENANCE

1. The air filter should be replaced when it turns gray. Additional filters can be procured from your dealer.
2. Only authorized personnel shall make repairs to this device.

 **CAUTION: The device may be damaged if used with a dirty filter or if the air filter is replaced by some other material such as cotton. Do NOT operate without the dedicated air filter.**

11. TROUBLESHOOTING

Check the following if the device should fail during operation. You can also refer to the pages of this manual for complete instructions.

Problem	Cause	Remedy
Nothing happens when the power switch is pressed.	The power cord is not connected correctly to the electrical outlet.	Check that the plug is inserted in an electrical outlet. Unplug then reinsert the plug if necessary.
No nebulization or low nebulization rate when the power is on.	There is no medication in the nebulizer cup.	Add the correct amount of medication to the nebulizer cup.
	There is too much/little medication in the nebulizer cup.	
	The cap of nebulizer cup is missing or not assembled correctly.	Attach the cap of nebulizer cup correctly.
	The accessory for inhale is not assembled correctly.	Assemble the accessory for inhale correctly.
	The nozzle of nebulizer cup is blocked.	Make sure that the nozzle is free of blockages.
	The nebulizer cup is tilted at a sharp angle.	Make sure that the nebulizer kit is not tilted at an angle of more than 45 degrees.
	The air tube is not connected correctly.	Make sure that the air tube is correctly connected to the compressor and accessory for inhale.
	The air tube is folded or damaged.	Make sure that the air tube does not contain kinks.
	The air tube is blocked.	Make sure that the air tube is free of blockages.
The air filter is dirty.	Replace the air filter with a new one.	
The device is abnormally loud.	The air filter cover is not attached correctly.	Attach the air filter cover correctly.
The device is very hot.	The device is covered by something.	Do not cover the device with any type of cover during use.
	The device was operated continuously for over 20 minutes.	Limit use to 20 minutes at a time, and allow a 40 minute rest interval before using the device again.

NOTE: If the suggested remedy does not solve the problem, do not try to repair the device. No parts of the unit are user serviceable. Return the unit to an authorized retail outlet or distributor.

12. TECHNICAL DATA

Particle Size: **MMAD** approximately 3 μm

Appropriate Medication Quantities: 2 ml minimum – 6 ml maximum

Nebulization rate: 0.33 ml/min (by weight loss)

Aerosol Output: **0.33 ml** (2 ml, 1%NaF)

Aerosol Output Rate: **0.06 ml/min** (2ml, 1%NaF)

Result of cascade impactor **measurements** for particle size

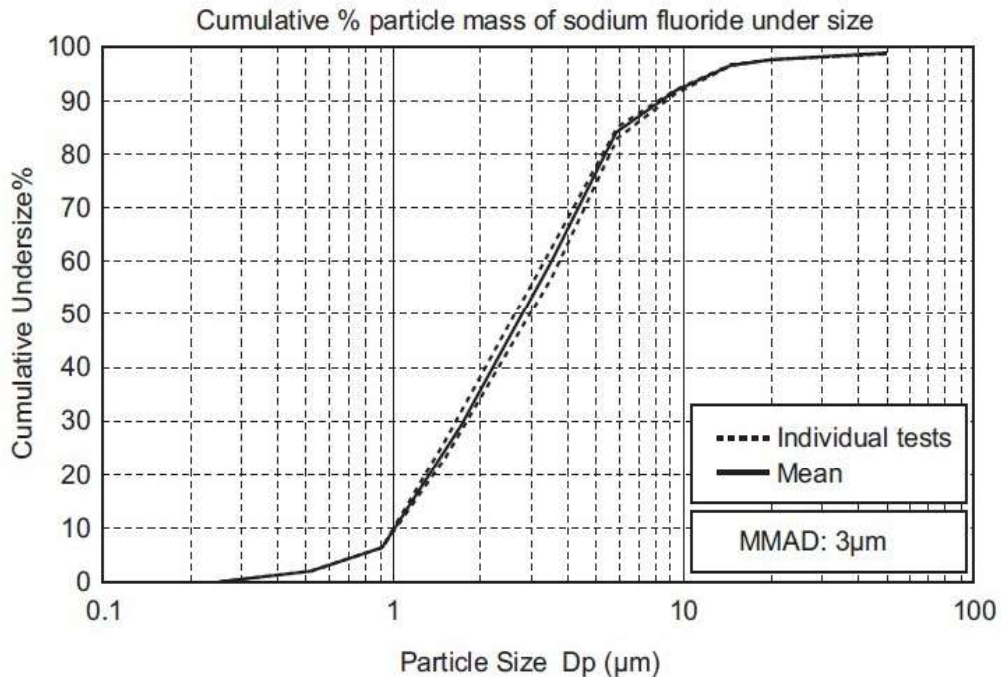

MMAD = Mass Median Aerodynamic Diameter

13. EMD TECHNICAL DATA

Medical Electrical Equipment needs special precautions regarding EMD and needs to be installed and put into service according to the EMD information provided in the following.

Portable and mobile RF communication equipment (e.g. cell phones) can affect Medical Electrical Equipment. The use of accessories and cables other than those specified may result in increased emissions or decreased immunity of the unit.

Table 1 - EMISSION Limits -

Phenomenon	Compliance
Conducted and radiated RF EMISSION CISPR 11	Group 1、 Class B
Harmonic distortion IEC 61000-3-2	Class A
Voltage fluctuations and flicker IEC 61000-3-3	Compliance

Table 2 - IMMUNITY TEST LEVELS : Enclosure Port -

Phenomenon	IMMUNITY TEST LEVELS
Electrostatic discharge IEC 61000-4-2	±8 kV contact ±2 kV, ±4 kV, ±8 kV, ±15 kV air
Radiated RF EM fields IEC 61000-4-3	10 V/m 80 MHz - 2.7 GHz 80 % AM at 1 kHz
Proximity fields from RF wireless communications equipment IEC 61000-4-3	See table 4
Rated power frequency magnetic fields IEC 61000-4-8	30 A/m 50 Hz or 60 Hz

Table 3 - IMMUNITY TEST LEVELS : Input a.c. power Port -

Phenomenon	IMMUNITY TEST LEVELS
Electrical fast transients / bursts IEC 61000-4-4	±2 kV 100 kHz repetition frequency
Surges Line-to-line IEC 61000-4-5	±0.5 kV, ±1 kV
Conducted disturbances induced by RF fields IEC 61000-4-6	3 V 0.15 MHz - 80 MHz 6 V in ISM and amateur radio bands between 0.15 MHz and 80 MHz 80 % AM at 1 kHz
Voltage dips IEC 61000-4-11	0 % U_T ; 0.5 cycle At 0°, 45°, 90°, 135°, 180°, 225°, 270°, and 315°
	0 % U_T ; 1 cycle And 70 % U_T ; 25/30 cycle Single phase: at 0°
Voltage interruption IEC 61000-4-11	0% U_T ; 250/300 cycle
NOTE U_T is the AC mains voltage prior to application of the test level.	

Table 4 - Test specifications for ENCLOSURE PORT IMMUNITY to RF wireless communications equipment -

Test frequency (MHz)	Band (MHz)	Service	Modulation	Maximum power (W)	Distance (m)	IMMUNITY TEST LEVEL (V/m)
385	380 - 390	TETRA 400	Pulse modulation 18 Hz	1.8	0.3	27
450	430 - 470	GMRS 460 FRS 460	FM ±5 kHz deviation 1 kHz sine	2	0.3	28
710	704 - 787	LTE Band 13,17	Pulse modulation 217 Hz	0.2	0.3	9
745						
780						
810	800 - 960	GSM 800/900 TETRA 800 iDEN 820 CDMA 850 LTE Band 5	Pulse modulation 18 Hz	2	0.3	28
870						
930						
1720	1700 -1990	GSM 1800 CDMA 1900 GSM 1900 DECT LTE Band 1,3,4,25 UMTS	Pulse modulation 217 Hz	2	0.3	28
1845						
1970						
2450	2400 - 2570	Bluetooth WLAN 802.11 b/g/n RFID 2450 LTE Band 7	Pulse modulation 217 Hz	2	0.3	28
5240	5100 - 5800	WLAN 802.11 a/n	Pulse modulation 217 Hz	0.2	0.3	9
5500						
5785						

14. CORRECT DISPOSAL OF THIS PRODUCT (WASTE ELECTRICAL & ELECTRONIC EQUIPMENT)

This marking  shown on this product and its literature, indicates that it should not be disposed of with other household wastes at the end of its working life. To prevent possible harm to the environment or human health from uncontrolled waste disposal, please separate this from other types of wastes and recycle it responsibly to promote the sustainable reuse of material resources.

Household users should contact either the retailer where they purchased this product, or their local government office for details of where and how they can dispose this item for environmentally safe recycling.

This device does not contain any hazardous substances.

MEMO



A&D Company, Ltd.

1-243 Asahi , Kitamoto-shi, Saitama 364-8585, JAPAN
Telephone: [81] (48) 593-1111 Fax: [81] (48) 593-1119



Shenzhen Bi-rich Medical Devices Co.Ltd,

The 1st Building of No. 10, Xinqiao GangZai Road, Xinqiao Street, Bao'An District ,518125,
Shenzhen City,Guangdong Province, P. R. China



SUNGO Cert GmbH

Lindenstraße 48-52, 40233 Dusseldorf, Germany

A&D INSTRUMENTS LIMITED

Unit 24/26 Blacklands Way, Abingdon Business Park, Abingdon, Oxfordshire OX14
1DY United Kingdom
Telephone: [44] (1235) 550420 Fax: [44] (1235) 550485

A&D ENGINEERING, INC.

4622 Runway Boulevard, Ann Arbor, MI 48108 USA
Telephone: [1] (888) 726-9966

A&D AUSTRALASIA PTY LTD

32 Dew Street, Thebarton, South Australia 5031, AUSTRALIA
Telephone: [61] (8) 8301-8100 Fax: [61] (8) 8352-7409

ООО A&D RUS ООО "ЭЙ энд ДИ РУС"

121357, Российская Федерация, г.Москва, ул. Вереysкая, дом 17
(Business-Center "Vereyskaya Plaza-2" 121357, Russian Federation, Moscow,
Vereyskaya Street 17)
тел.: [7] (495) 937-33-44 факс: [7] (495) 937-55-66

A&D Technology Trading(Shanghai) Co.Ltd 爱安德技研贸易(上海)有限公司

中国 上海市自由贸易试验区浦东南路855号世界广场32楼C,D室 邮编200120
(32CD, World Plaza, No.855 South Pudong Road,China (Shanghai) Pilot
Free Trade Zone, 200120, China)
电话: [86] (21) 3393-2340 传真: [86] (21) 3393-2347

A&D INSTRUMENTS INDIA PRIVATE LIMITED

ऐ&डी इन्स्ट्रूमेन्ट्स इण्डिया प्रा० लिमिटेड

509, उद्योग विहार , फेस -5, गुडगांव - 122016, हरियाणा , भारत
(509, Udyog Vihar, Phase-V, Gurgaon - 122 016, Haryana, India)
फोन : 91-124-4715555 फैक्स : 91-124-4715599