

**TM-2560G / TM-2564G**  
**TM-2560GP / TM-2564GP**

**VITAL SENSOR**  
**GRAPHIC MODEL**

**INSTRUCTION MANUAL**



**WM+PD4000753**

© 2004 A&D Company Ltd. All rights reserved.

No part of this publication may be reproduced, transmitted, transcribed, or translated into any language in any form by any means without the written permission of A&D Company Ltd.

The contents of this manual and the specifications of the instrument covered by this manual are subject to change for improvement without notice.

# Compliance

## Compliance with FCC Rules

This device complies with Part 15 of the FCC Rules. Operation is subject to the following two conditions: (1) This device may not cause harmful interference, and (2) this device must accept any interference received, including interference that may cause undesired operation.

(FCC = Federal Communications Commission in the U.S.A.)

## Compliance with European Directive 93/42 EEC for Medical Products

This device conforms to European Directive 93/42 EEC for Medical Products. This is evidenced by the CE mark of conformity accompanied by the reference number of a designated authority.

# Warning Definitions

The warnings described in this manual have the following meanings:



**Warning**

**Disregarding the warning could result in bodily injury or damage to the instrument.**



**Caution**

**Disregarding the caution could result in loss of important user data or damage to the instrument.**

### **Note**

Provides information useful for the user to operate the instrument.

In addition to these shown above, there are more precautions specific to each section. Read the manual carefully and observe the precautions.

# General Precautions

To handle the instrument properly and safely, read the instruction manual thoroughly and be fully knowledgeable about the instrument before use.

The following are general precautions on handling the instrument safely and safety of patients and operators. Precautions specific to the instrument will appear in the relevant pages.

## **The following points should be considered when you install or store the instrument.**

- Install or store the instrument away from moisture.
- Install or store the instrument in an environment where the instrument is not badly affected by extreme temperature, humidity, atmospheric pressure, direct sunlight, draft, dust, salinity or sulfur content in the air.
- Install or store the instrument in a secure and stable location.
- Do not install or store the instrument where chemicals, and corrosive or explosive gases are stored or present.
- Install the instrument where a 3-pin electrical outlet adequate to the instrument is provided.
- This instrument is not of the explosion-proof type. Do not use the instrument where flammable materials, such as a flammable anesthetic, are used.

## **The following points should be considered before use**

- Check to make sure the instrument operates safely and accurately.
- Check all hoses and cables for proper connection and deterioration.
- When the instrument is used in combination with other instruments, pay extra attention to avoid mis-diagnosis or other problems especially leakage current. Check all connections to make sure they do not interfere with each other.
- When other telemeters are used, check that mutual interference will not cause a problem.
- When the instrument is operated using batteries, check that the specified batteries are used and they are installed properly and in good conditions.
- Use the AC adapter provided with the instrument.
- Use the specified sensors.

## **The following points should be considered during use.**

- The instrument should be used only during the time required for diagnosis and medical treatment.
- Check the patient and the instrument during use.  
If medical or operational problems are found in the instrument or the patient, stop using the instrument immediately, check the status of the patient and take proper actions.
- Do not allow a patient to touch or operate the instrument.
- Do not use the instrument where strong magnetic or electrical field exists.
- Do not use the instrument on a patient using a heart-lung machine.

- High frequency interference by electrosurgery or energy discharged by a defibrillator may damage the instrument. Follow the precautions described in the manual for each device.  
(The instrument is protected against the energy discharged by a defibrillator only when the accessory ECG extension cable is used.)
- During electrosurgery, do not connect the ECG electrodes to the patient. (They may cause the patient to be burned.)
- Do not use a cellular telephone near the instrument. It could affect the instrument's operation.

**The following points should be considered after use.**

- Follow a predetermined procedure to return the operation switches to their original positions, and then turn off the power.
- Do not forcibly pull out the cables and hoses.
- Keep the instrument clean and in proper operating condition so that it can be used without problem during the next operation.
- Clean the accessories and arrange them before storage.

**Perform the following when the instrument malfunctions.**

- Secure the patient's or operator's safety.
- Turn the power off and disconnect the power cable from the outlet.
- Affix a notice such as "Out of Order" and "Do Not Use" on the device. Ask the nearest dealer for services.

**Do not disassemble or modify the device.**

**Perform regular maintenance and inspection of the instrument.**

- This is a precision instrument. Please check all functions and cables periodically.
- If the instrument is used for the first time after an extended period of storage, check it for proper operation.
- Use a soft, dry cloth for removing stains from the instrument. Do not use solvents such as thinner or benzine.

**Strong electromagnetic waves may affect the instrument performance.**

When the instrument is used near a strong electromagnetic field, it may malfunction and noises occur in the waveform. If the instrument malfunctions unpredictably, check the environment for electromagnetic fields and take adequate measures.

The following are typical causes of electromagnetic fields and measures against them.

- Cellular telephones  
Electric waves transmitted by a cellular telephone can cause the instrument to malfunction.
  - Turn off cellular telephones and other radio devices in medical facilities.

- High-frequency noises from other devices through the electrical outlet
  - Locates the noise source and eliminate its route using adequate measures such as a noise elimination device.
  - Turn off the device that serves as a noise source, if possible.
  - Use another electrical outlet.
- Static electricity discharged by the instrument or the environment
  - Discharge static electricity fully from the operator and the patient before use.
  - Humidify the room.
- Lightening
 

Lightening occurring nearby may induce great amount of voltage to the instrument. Under such a condition, operate the instrument as follows:

  - Disconnect the power cable from the electrical outlet and use the battery.
  - Use the uninterruptible power system that complies with IEC60601-1.
- When using the instrument cause noise to the receiver such as a TV or radio, locate those receivers away from the instrument.

#### **Environmental protection**

- Remove the built-in lithium battery from the instrument when the instrument is to be disposed of.

# Safety Precautions

The following are the cautions on measurements and sensors.

## Blood pressure measurement



- Warning**
- Blood pressure may not be measured when noise, such as consecutive irregular heart rhythm and physical movement, is present. Check the reliability of the measured value by displaying or printing the pulse graph.
  - The instrument takes preventive measures against artifact and shock. However, if you have some doubts about the measured values, check the blood pressure by other methods.
  - Position the cuff at the same height as the patient's heart. Otherwise, a measurement error may occur.
  - Use the cuff appropriate to the patient's arm circumference. Otherwise, a measurement error may occur.
  - The maximum length of the hose is 3.5 (2 m + 1.5 m) meters long. Using a longer hose may lower the amplitude level of the detected pulse and affect the measurement.
  - Do not use a twisted or tangled hose as it is. The air may be trapped in the cuff and cause peripheral circulation disorder by stopping the blood circulation in the arm.
  - Measuring the blood pressure may cause minor hemorrhaging beneath the skin. The hemorrhage is temporary and disappears with time.
  - Do not attach the cuff on a scar. The scar may worsen and cause infection.
  - Do not attach the cuff on an arm where intravenous drip or blood transfusion is performed.

## Cuff



- Warning**
- The cuff contains dry natural rubber. Natural rubber can cause allergic reactions such as itching, redness, hives, swelling, fever, breathing difficulty, asthmatic reactions, blood pressure drop and shock. If the patient exhibits such a symptom, stop using the instrument immediately and seek medical treatment.

### Heart rate/pulse rate measurement



#### Warning

- Monitor a patient using a pacemaker closely while measuring the heart rate.
- Do not diagnose arrhythmia other than bradycardia or tachycardia by using the pulse rate displayed and detected by the instrument.



#### Caution

- The instrument employs three types of heart rate/pulse rate detection methods.
  - Heart rate by QRS detection from the ECG waveform (Only for models with ECG)  
(The value is displayed in green.)
  - Pulse rate by arterial oxygen saturation (SpO<sub>2</sub>) measurement  
(The value is displayed in blue.)
  - Pulse rate by blood pressure measurement  
(The value is displayed in yellow.)

### Transcutaneous arterial oxygen saturation measurement



#### Warning

- Correct measurements may not be performed in the following cases:
  - When pigment is introduced into the blood vessel
  - When nails are coated with nail polish
  - When physical movement is present
  - When the sensor is firmly tightened.
  - When carboxyhemoglobin and/or methemoglobin concentration cannot be ignored.
  - During electrosurgery
  - During CPR
  - When measured on the body part where venous pulsations exist
  - When the pulse wave is small
  - When the patient has low perfusion
  - When the sensor temperature is out of the range of 28°C to 42°C.
- When not in use, disconnect the cable from the instrument. Noise may enter an unused sensor, causing an erroneous display.
- Always monitor the SpO<sub>2</sub> plethysmograph and pulse wave bar graph to check against bad blood circulation.
- Excessive light may cause inaccurate measurements. In such cases, cover the sensor with an opaque material.
- Use the specified SpO<sub>2</sub> sensor for accurate measurement.
- If the sensor is wrapped too tightly or supplemental tape is applied, venous pulsations may lead to inaccurate saturation measurements.



## SpO<sub>2</sub> sensor

Use a Nellcor sensor listed in the following table.

Type	Disposable						Reusable				
Model	OXISENSOR										
Parts #	MAX A	MAX AL	MAX P	MAX I	MAX N	MAX R	DURA-Y	DS100A	RS10	OXI-A/N	OXI-P/1
Compatibility	Yes	Yes	Yes	Yes	No	Yes	Yes	Yes	No	Yes	Yes

**Read the instruction manual supplied for the sensor carefully before use.**



### Warning

- Finger clip type sensor
  - Use only for adult fingers. Do not use the sensor on other body parts.
  - For short term monitoring. If the sensor is to be used for 4 hours or longer, alternate fingers used. For extended monitoring, use a flex type sensor.
  - Do not affix the sensor to the finger with tape. This may cause congestion or edema, resulting in skin damage.
  - When cleaning the sensor, clean with a cloth moistened with 70% alcohol or other disinfectant.
- Flex type / Disposable sensor
  - Though the sensor is suitable for long term monitoring, check the skin and sensor mount at fixed intervals (every 8 hours). If a change or discoloration in skin is detected, move the sensor to another area.
  - If strong light affects the sensor, cover it with an opaque material.
  - When securing the sensor with tape, avoid tightening too strongly to prevent congestion and edema.
  - If the patients exhibit allergic reactions to the adhesive tape, stop using the sensor. Care must be taken while peeling off adhesive tape.
- The temperature on the body part where the SpO<sub>2</sub> sensor is attached rises by 2°C to 3°C, that may cause compression necrosis or burns. If the patient has a fever or suffers from peripheral circulation disorder, change the sensor site frequently.



### Caution

- The disposable sensor is sterilized for single use on a single patient. Do not re-use it on another patient.

### Note

- Refer to the manual of each sensor for details.

# Unpacking / Inspection



**Caution**

**This is a precision instrument. Handle it with care. Strong shock may cause failure.**

## Note

This instrument is delivered in a packing box designed to prevent damage during normal transportation. When unpacking the instrument, check it for damage. If your instrument has been damaged, contact the agent you purchased it from. Retain the packing materials, which are required to transport this instrument.

Check that the following articles are included when you unpack the instrument.

	TM-2560G	TM-2564G	TM-2560GP	TM-2564GP
Main unit	✓	✓	✓	✓
Instruction manual	✓	✓	✓	✓
Adult cuff with 2-meter hose	✓	✓	✓	✓
1.5-meter hose	✓	✓	✓	✓
SpO <sub>2</sub> extension cable	✓	✓	✓	✓
ECG extension cable		✓		✓
ECG patient cable		✓		✓
AC adapter	✓	✓	✓	✓
Power cable	✓	✓	✓	✓
Printer paper (white) 5 rolls			✓	
Printer paper (graph) 2 rolls				✓
SpO <sub>2</sub> sensor pack (with instruction manual)	✓	✓	✓	✓
Battery	✓	✓	✓	✓

✓ = Available

TM-2560G/TM-2564G

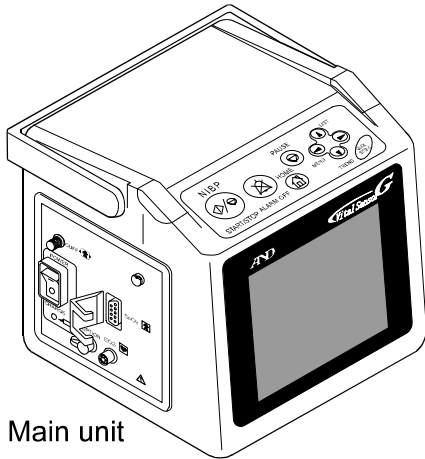

Main unit

TM-2560GP/TM-2564GP

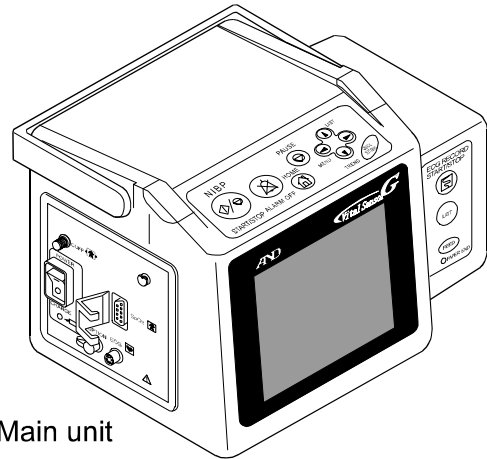

Main unit

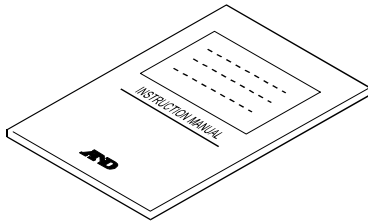

Instruction manual

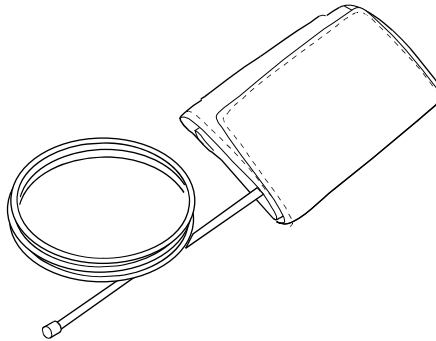

Adult cuff with 2-meter hose

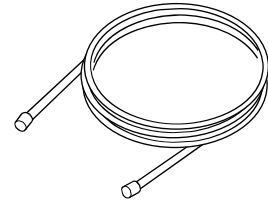

1.5-meter hose

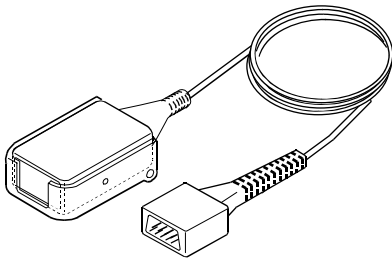

SpO<sub>2</sub> extension cable



SpO<sub>2</sub> sensor pack  
(with instruction manual)

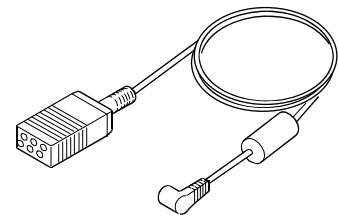

ECG extension cable

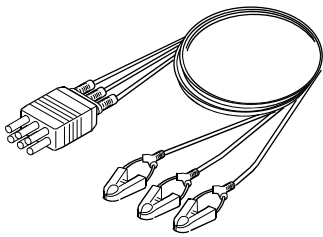

ECG patient cable

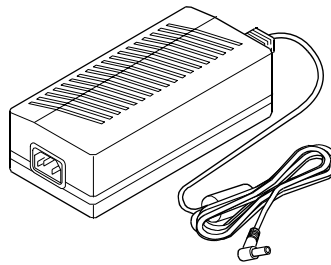

AC adapter

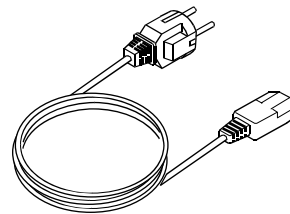

Power cable

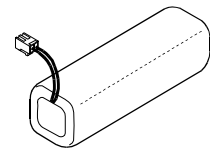

Battery

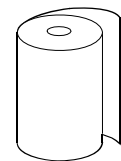

Printer paper

# Contents

<b>Compliance</b> .....	<b>i</b>
<b>Warning Definitions</b> .....	<b>i</b>
<b>General Precautions</b> .....	<b>ii</b>
<b>Safety Precautions</b> .....	<b>v</b>
<b>Unpacking / Inspection</b> .....	<b>viii</b>
<b>1. Introduction</b> .....	<b>3</b>
1-1 Features .....	3
<b>2. Specifications</b> .....	<b>4</b>
2-1 Models .....	4
2-2 Main Unit .....	4
2-3 Measurement .....	5
<b>3. Part Names</b> .....	<b>6</b>
3-1 TM-2560G/TM-2564G .....	6
3-2 TM-2560GP/TM-2564GP .....	7
3-3 Top Operation Panel.....	8
3-4 Printer Keys.....	9
3-5 Symbols.....	9
<b>4. Preparation Before Use</b> .....	<b>10</b>
4-1 Installation Site .....	10
4-2 Power Supply .....	10
4-3 Installation Procedure.....	13
4-4 Printer Paper Loading Procedure.....	13
<b>5. Displays</b> .....	<b>14</b>
5-1 Home Display .....	14
5-2 List Display .....	20
5-3 Trend Display .....	21
5-4 Pause Display .....	22
5-5 Setting Mode Display .....	23
5-6 Quick Setting Window .....	24
<b>6. Operation</b> .....	<b>25</b>
6-1 Turning on the POWER switch.....	25
6-2 Attaching the Cuff/ECG Electrodes/SpO <sub>2</sub> Sensor .....	25
6-3 Setting Mode .....	28
6-4 Quick Setting Mode.....	31
6-5 Measuring the Blood Pressure.....	32

6-6 Measuring the ECG .....	33
6-7 Measuring the SpO <sub>2</sub> .....	34
6-8 Measuring the Temperature (Optional) .....	34
6-9 Measuring the Heart Rate/Pulse Rate .....	34
6-10 Alarm Function .....	35
6-11 Storing/Deleting Data.....	35
6-12 Power Supply .....	37
6-13 Printing the Measurement Data .....	37
6-14 Function Setting .....	40
<b>7. Maintenance .....</b>	<b>42</b>
7-1 Cleaning .....	42
7-2 Calibration .....	43
7-3 Assembling the Cuff .....	44
7-4 Disposing of the Instrument .....	44
7-5 Before Asking for a Repair .....	44
7-6 Error Codes .....	45
<b>8. Accessories/Options .....</b>	<b>46</b>
<b>Appendix A: Measuring Principle .....</b>	<b>47</b>
A-1 Blood Pressure .....	47
A-2 SpO <sub>2</sub> .....	49
<b>Appendix B: External Dimensions .....</b>	<b>51</b>

# 1. Introduction

Thank you for purchasing Vital Sensor Graphic Model from A&D. This manual was written for the TM-256XG series. Available functions depend on the model.

Please read the manual carefully before using the instrument in order to ensure a sufficient understanding of the TM-256XG series and provide proper use. Store the manual in a readily available location.

## 1-1 Features

---

- All-in-one monitor instrument allows measurement of blood pressure, arterial oxygen saturation (SpO<sub>2</sub>), and heart rate by the ECG. (Monitors vital signs information of general ward inpatients.)
- TFT color LCD for easy recognition of measurement values and waveform.
- The oscillometric method is used for blood pressure measurement.
- The automatic pressurization function pressurizes to an optimum pressure according to the patient's blood pressure to prevent excessive pressurization.
- The interval measurement is an exact-time measurement synchronized with the built-in clock, allowing the patient record and anesthesia data to be recorded.
- In the interval measurement mode, the quick systolic blood pressure detection function displays the predicted systolic blood pressure value.
- The pulse oximeter is provided with a function to compensate for variations in the quantity of light transmitted according to the tissue density and skin coloration at the measurement site.
- An optional temperature receiver unit is available for monitoring the temperature continuously.
- An optional extension box is available for selecting various types of communications functions.
- A rechargeable battery is available for using the instrument during transportation or where there is no AC power supply.
- The instrument is lightweight, compact and easy to carry.

## 2. Specifications

### 2-1 Models

	TM-2560G	TM-2564G	TM-2560GP	TM-2564GP
Blood pressure measurement	✓	✓	✓	✓
ECG measurement		✓		✓
SpO <sub>2</sub> measurement	✓	✓	✓	✓
Limit function	✓	✓	✓	✓
Interval measurement	✓	✓	✓	✓
Printing function			✓	✓

### 2-2 Main Unit

External dimensions	Without printer: 160 (W) x 143 (H) x 138 (D) mm With printer: 205 (W) x 143 (H) x 138 (D) mm Excluding the rubber feet and handle
Mass	Without printer: Approx. 1.2 kg With printer: Approx. 1.4 kg Excluding the battery and printer paper
Power supply	AC adapter (TB223) Input: 100-240 VAC, 50-60 Hz, 65-86 VA Output: 15 VDC, 2A
	Battery (AX-HHR-21HL24G1) Type: Nickel-metal-hydride Operating hours: Approx. 1.5 hours when a new battery is used with 5-minute interval and without printing
Protection against electrical shock	On AC adapter: Class 1
	On battery: Internally powered equipment
Limit function	Systolic blood pressure, diastolic blood pressure, heart rate (pulse rate), SpO <sub>2</sub> , and temperature* Flashes value and alarm lamp, and sounds alarm in an emergency
Display	Backlit TFT color LCD (5 inches, 320 x 234 dots)
Displaying function	Waveform: ECG waveform, plethysmograph Number of waveforms: Maximum 2 traces Waveform display method: Stationary trace Values: Systolic, diastolic, mean, heart rate (pulse rate), SpO <sub>2</sub> , temperature* List: Systolic, diastolic, heart rate (pulse rate), SpO <sub>2</sub> , temperature* Trend: Systolic, diastolic, heart rate (pulse rate), SpO <sub>2</sub> , temperature* Pause: ECG waveform, plethysmograph
Printer	Thermal line printer Paper width: 58 mm
Printing function	Waveform printing: ECG waveform (16 seconds) Graph, list, trend printing: Systolic, diastolic, heart rate (pulse rate), SpO <sub>2</sub> , and temperature*
Memory function	Number of memory data: 400 Storage cycle: 1, 2, 2.5, 3, 5, 10, 15 minutes
Backup function	Time: Built-in lithium battery Memory data: Non-volatile memory
Operating temperature/humidity	+10°C to +40°C, 85%RH or less
Storing temperature/humidity	-20°C to +55°C, 95%RH or less
Operating atmospheric pressure	70 to 106 kPa

\* Available only when the optional thermometer and temperature receiver unit are connected.

## 2-3 Measurement

Blood pressure	<p>Measurement method: Oscillometric method            Pressure detection method: Semiconductor pressure sensor            Pressure range: 0 - 300 mmHg            Pressure accuracy: <math>\pm 3</math> mmHg            Measurement range: Blood pressure: 10 - 280 mmHg            Pulse rate: 30 - 200 bpm (Neonate: 30 - 240 bpm)            Pressurizing method: Diaphragm pump            Pressure control method: ECEV            Rapid air exhaust system: Electromagnetic valve            Safety mechanism: The electromagnetic valve opens when approx. 320 mmHg or greater is detected.            For neonates, the electromagnetic valve opens when 160 mmHg is detected.            Degree of protection against electrical shock: Type BF</p>
Blood pressure interval measurement	<p>Intervals: CON, 2.5, 3, 5, 10, 15, 20, 30, 60, 90, 120 min.            Maximum length of CON measurement is 5 minutes. After five minutes, the interval is switched to 5-min interval automatically.</p>
SpO <sub>2</sub>	<p>Measurement method: 2-wavelength pulse oximetry            Measurement range: 40 - 100%            Accuracy: <math>\pm 3</math> % (70-100%)            Pulse rate measurement range: 30 - 250 bpm            Degree of protection against electrical shock: Type BF</p>
ECG	<p>Patient input            Lead: 3-lead (Lead I, II, III)            Input impedance: 5 M<math>\Omega</math> or greater            Input circuit current: 10<sup>-7</sup> A or less            Differential dynamic range: <math>\pm 300</math> mV            Degree of protection against electrical shock: Type CF</p>
	<p>Measurement            Frequency characteristics: 0.3 - 60 Hz (when 0.5 second of time constant is selected)            0.05 - 200 Hz (when 3.2 seconds of time constant is selected)            Hum elimination: 50/60 Hz            Measurement range: 20 - 300 bpm</p>



### Caution

For safety and best performance, use the specified accessories and options.

If ECG electrodes other than specified are used, use much care. A great offset may occur.



# 3. Part Names

## 3-1 TM-2560G/TM-2564G

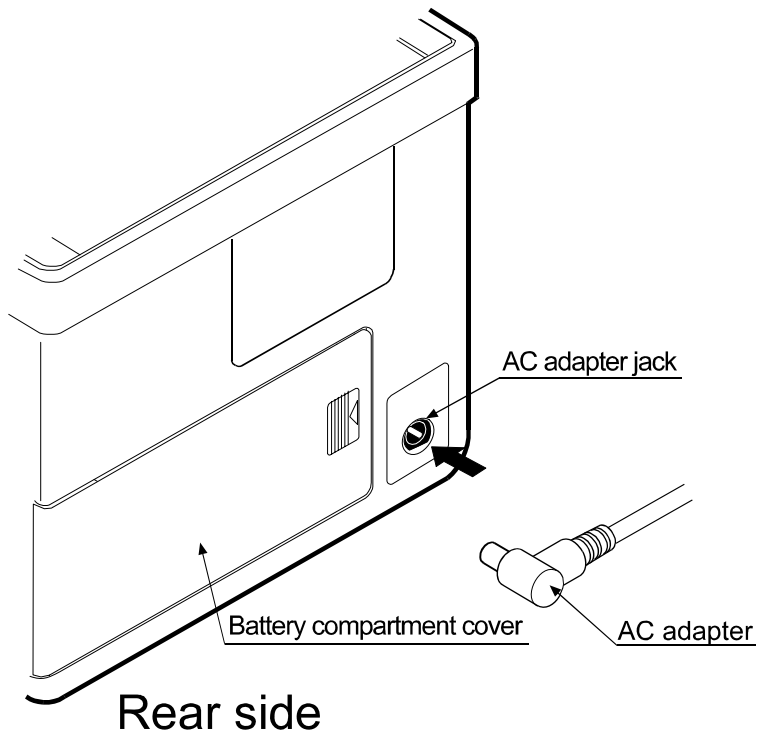
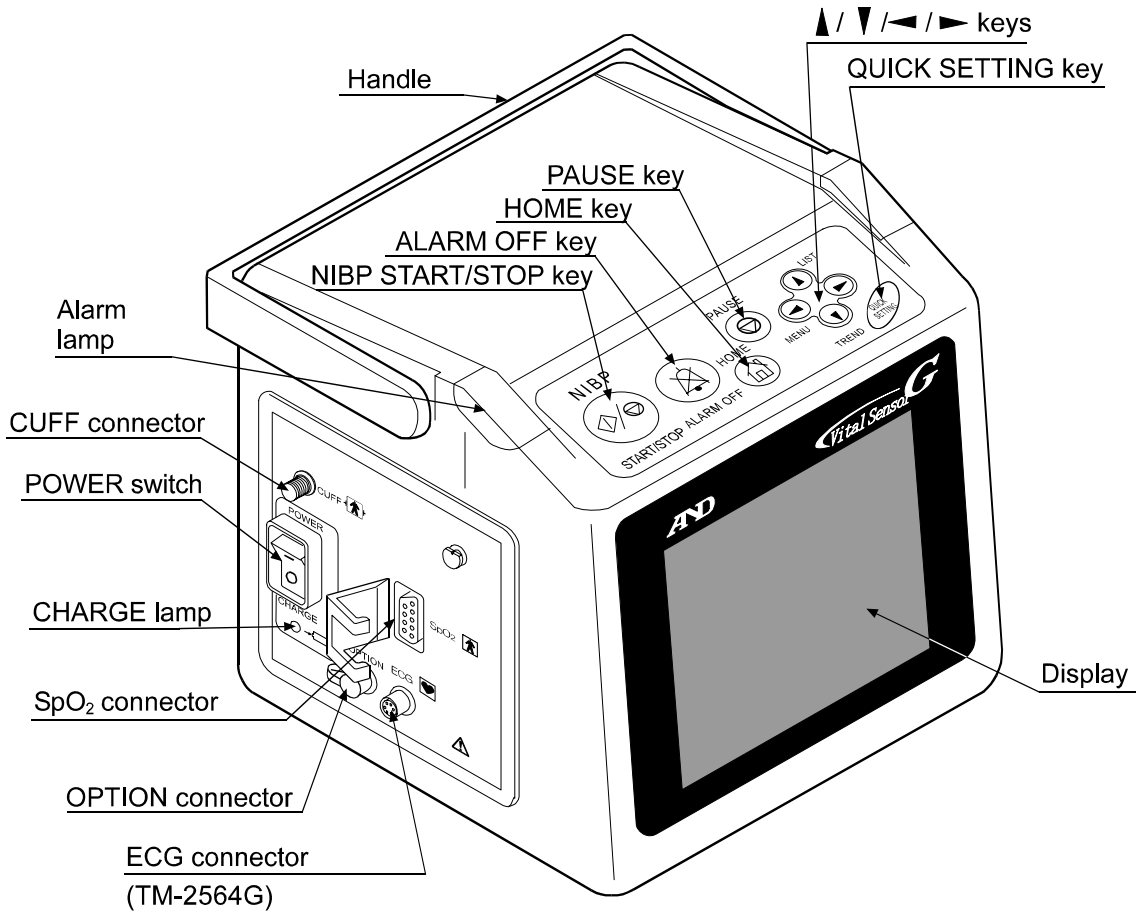

### 3-2 TM-2560GP/TM-2564GP

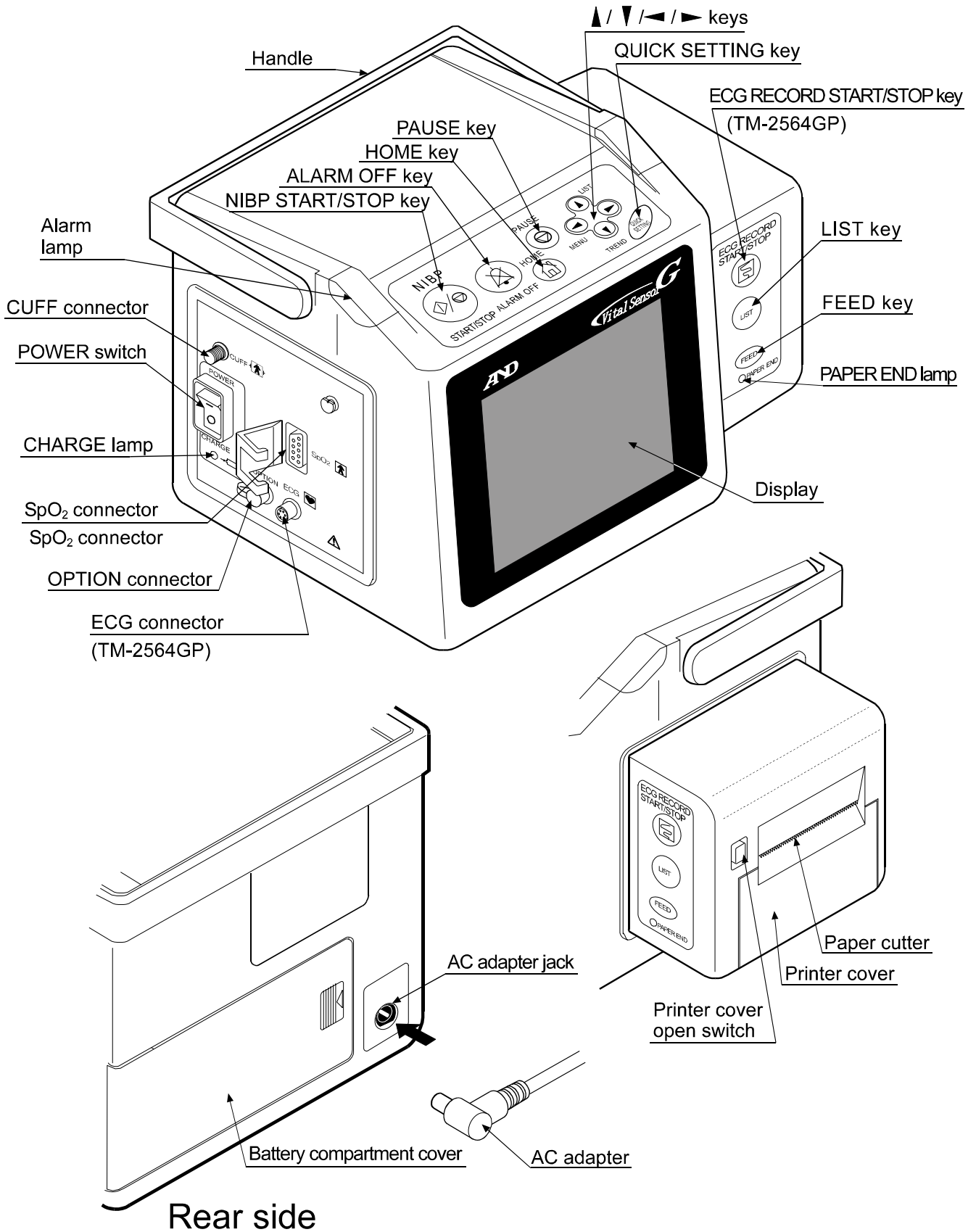

### 3-3 Top Operation Panel

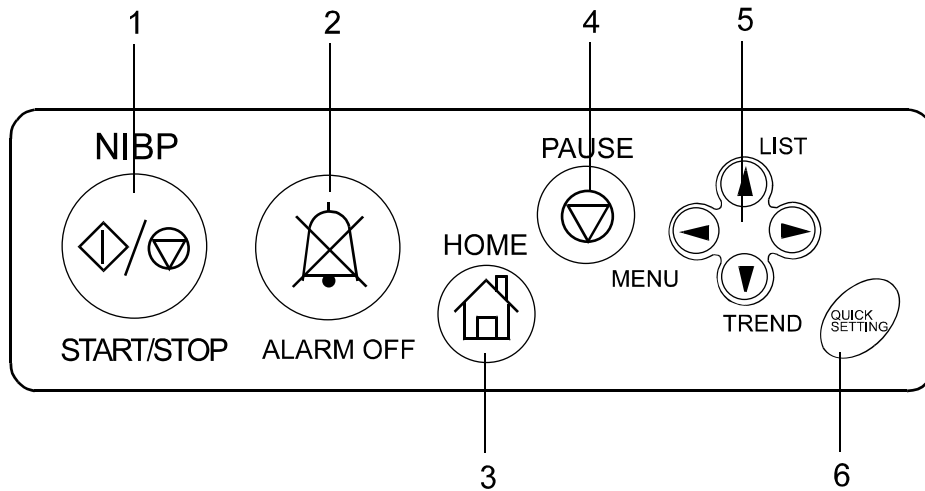

	Name	Function
1	NIBP START/STOP key	Starts or stops the blood pressure measurement.
2	ALARM OFF key	Stops the alarm buzzer. (Refer to "6-10 Alarm function".)
3	HOME key	Selects a home display to be displayed. Returns to the home display when the list, trend or setting mode is displayed.
4	PAUSE key	Pauses the ECG waveform or plethysmograph. Returns to the previous home display when pressed again.
5	▲ / ▼ / ◀ / ▶ keys	Goes to the following display from the home display. ◀ key: Goes to the setting mode display. ▲ key: Goes to the list display. ▼ key: Goes to the trend display. In a display other than the home display, each key functions as described in the key function guidance at the bottom of the display.
6	QUICK SETTING key	Opens the quick setting window. (Refer to "5-6 Setting Mode Display" and "6-4 Quick Setting Window".)

### 3-4 Printer Keys

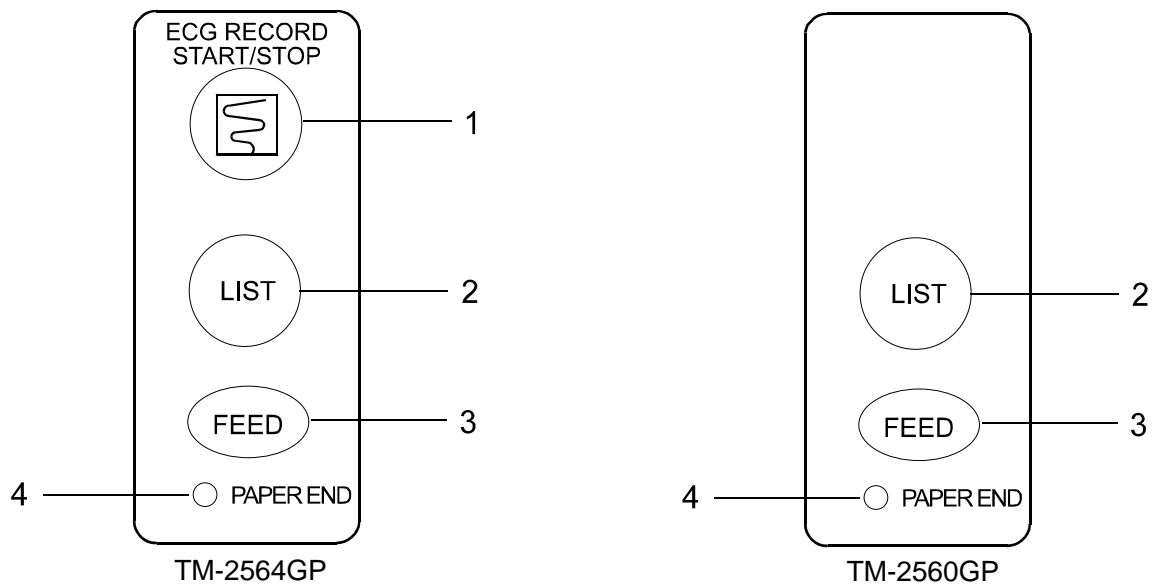

	Name	Function
1	ECG RECORD START/STOP key	Prints the ECG waveform. Functions as the PAUSE key when the waveform is printed.
2	LIST key	Prints the memory data in tabular form. (Refer to "6-13 Printing the Measurement Data")
3	FEED key	Feeds the paper.
4	PAPER END lamp	Illuminates when paper runs out or the printer case is open.

### 3-5 Symbols

Symbol	Description
	Indicates to refer to the instruction manual.
	Indicates that the POWER switch is "ON".
	Indicates that the POWER switch is "OFF".
	Indicates that the degree of protection against electrical shock is type BF. (Applicable to the SpO <sub>2</sub> sensor)
	Indicates that the degree of protection against electrical shock is type CF. (Applicable to the ECG patient cable)
	Indicates that the degree of protection against electrical shock is type BF. (Defibrillator protection) (Applicable to the cuff)
	Indicates that the degree of protection against electrical shock is type CF. (Defibrillator protection) (Applicable to the ECG patient cable when used with the AX-KO1839 extension cable)
	Indicates that the battery is being charged.

## 4. Preparation Before Use

### 4-1 Installation Site

When installing the instrument, consider "General Precautions" appearing in an earlier part of the instruction manual.

### 4-2 Power Supply

The instrument can be operated using an AC adapter or battery.

#### When an AC adapter is used:

1. Connect the supplied power cable to the AC adapter. Insert the plug on the other end of the power cable into an electrical outlet.

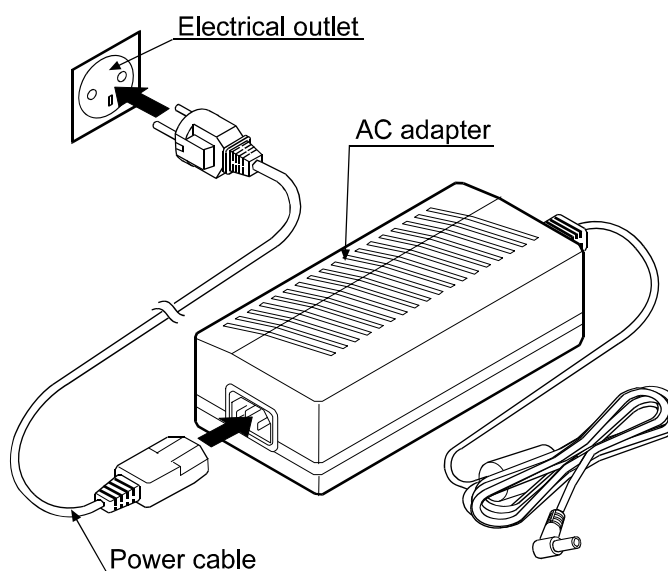

2. Insert the AC adapter cable into the AC adapter jack on the rear of the instrument.

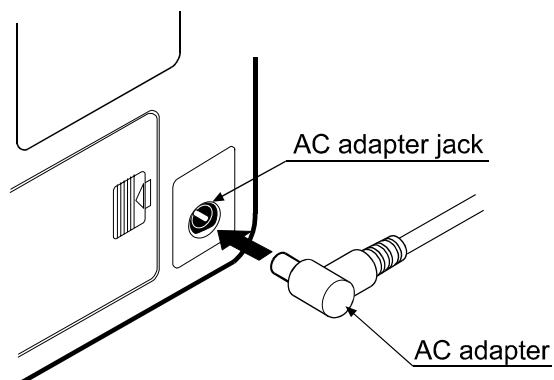

Use the specified power cable and AC adapter only.

## When the battery is used:

1. Remove the power cable from the electrical outlet.
2. Remove the screw from the battery compartment cover on the rear of the instrument.
3. Slide the cover to remove it.

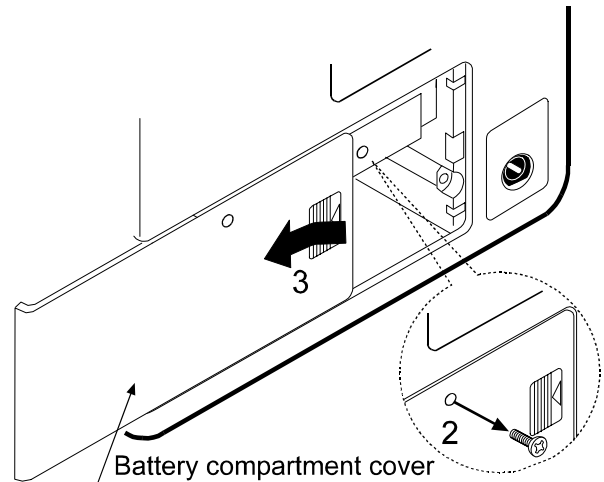

4. Insert the battery connector into the connector port of the battery compartment as shown in the illustration.
5. Install the battery as shown in the illustration, using much care to avoid damaging the cables. Mate the portion that the cables come out to the groove of the battery compartment.
6. Slide the cover to install it.
7. Screw the cover.

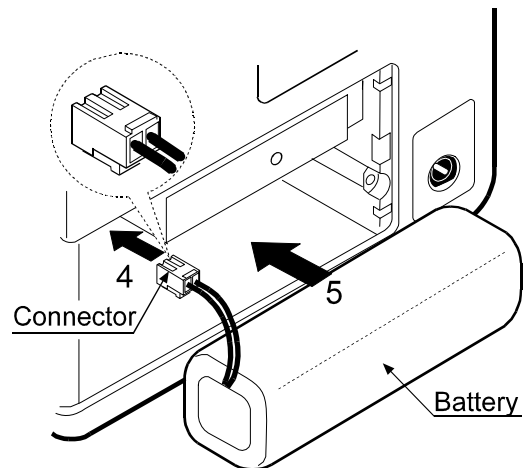

**Caution**

**Use the specified battery only.**

## Switching the power supply

When the AC adapter does not supply power, under the conditions as described below, the instrument automatically starts battery operation.

- The AC adapter cable is removed from the instrument.
- The power cable is removed from the electrical outlet.
- Power failure



**Caution**

**Power supply is switched automatically. The power supply currently used appears at the lower right side of the display. Refer to "6-12 Power Supply" for details.**

## Charging the battery

- Charging starts when the AC adapter is connected to the instrument, regardless of the power switch status. It takes 15 hours to complete charging.
- The battery capacity lowers due to self-discharge. To compensate the capacity lost due to self discharge, intermittent charging is performed automatically.
- When charging a battery with small charging capacity, supplementary charging of about one hour is performed.
- Charging status is indicated by the charging lamp.

Charging lamp	Charging status	Description
Lit continuously.	Charging of 15 hours is being performed. Right after the AC adapter is connected.	Normal condition
	Intermittent charging of 4 hours is being performed. Occurs about once a week when the AC adapter is kept connected after 15-hour charging.	Normal condition
Flashes every ten seconds	Supplementary charging is being performed. Occurs in the early stage of 15-hour charging.	Normal condition when the lamp stops flashing and is lit after a maximum of 4 hours.
Flashes every two seconds	Error	Remove the battery once and install again. If the condition persists, replace the battery.
Not lit	Charging is complete.	Normal condition.

### Note

- When the operating hours of the battery are short even after charging, replace the battery. Refer to "8-1 Accessories/Options" for ordering information.
- Replace the battery every two years.
- The battery may have deteriorated before two years of use, due to the environment and usage conditions.
- For battery operation, refer to "6-12 Power Supply".
- When the charging lamp will not light right after the AC adapter is connected, remove the battery and install it again.

## 4-3 Installation Procedure



### Warning

- Do not use damaged cables and sensors.
- Use the specified cables and sensors only.
- The ECG unit is protected against defibrillator discharge only when the supplied ECG extension cable is used.

1. Confirm that the power switch is turned off.
2. Connect the cuff hose to the CUFF connector of the instrument. Use the 1.5-m hose to extend it, if necessary.
3. Connect the SpO<sub>2</sub> extension cable to the SpO<sub>2</sub> connector of the instrument and lock it.
4. Connect the SpO<sub>2</sub> cable to the SpO<sub>2</sub> extension cable.
5. Connect the ECG extension cable to the ECG connector of the instrument. Confirm that it is securely connected.
6. Connect the ECG patient cable to the ECG extension cable.

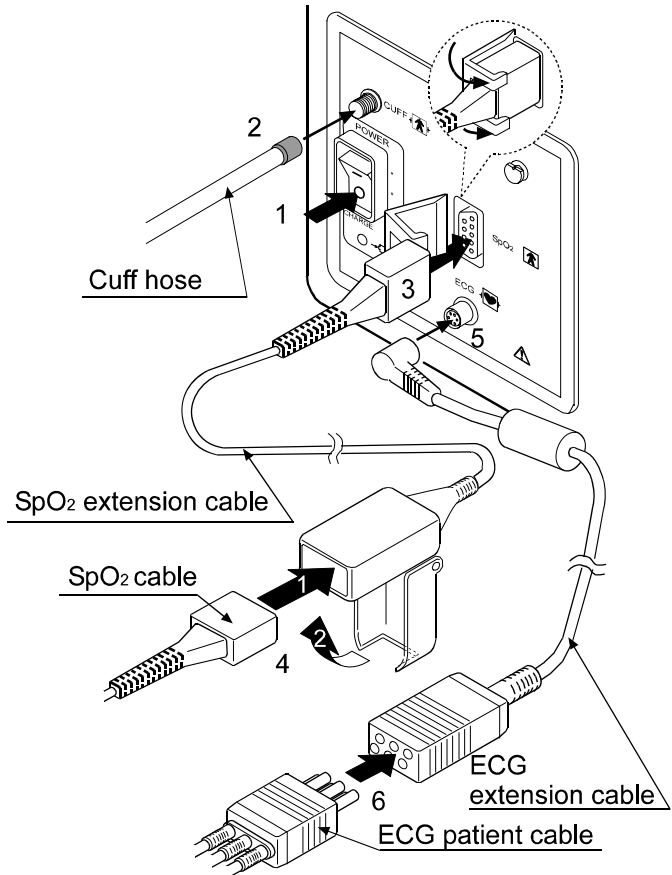

## 4-4 Printer Paper Loading Procedure

1. Press the printer cover open switch to open the printer cover.
2. Load the printer paper as shown in the illustration, and close the cover.
3. Press the FEED key to check that the paper is fed properly.
4. Cut the leading edge of the printer paper at a right angle.

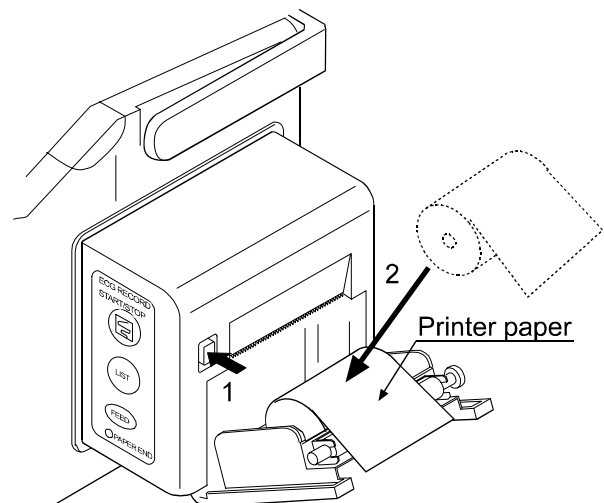



# 5. Displays

## 5-1 Home Display

Press the HOME key to indicate the home display. There are six home display types

### 1. Blood pressure 2 traces (Default display)

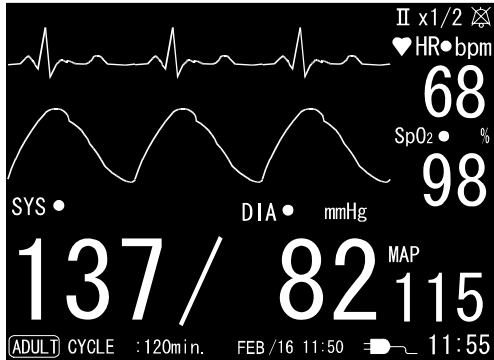

Emphasizes the blood pressure values



### 2. Waveform 2 traces

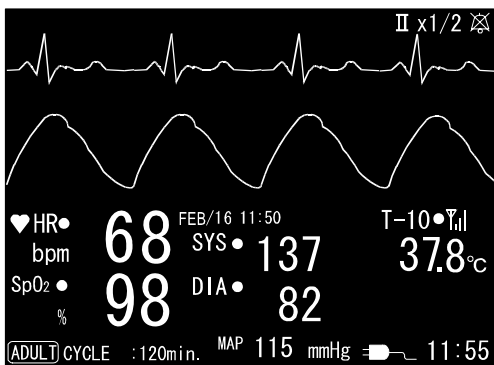

Lengthened waveform display area



### 3. Pulse graph 1 trace



Displays the pulse graph



### 6. Sleep mode

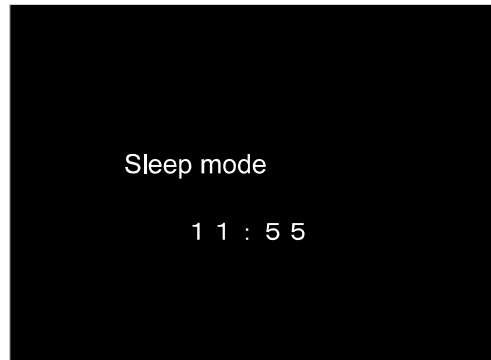

Blank display



### 5. Temperature 1 trace

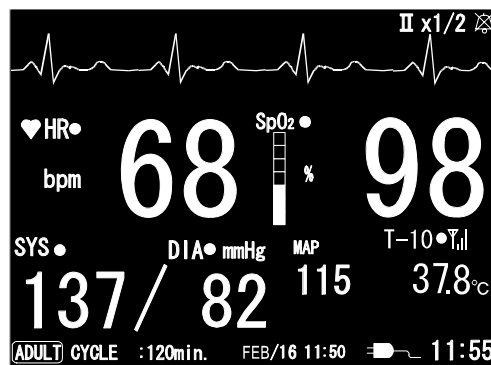

Emphasizes the heart rate and SpO<sub>2</sub>



### 4. Temperature 2 traces

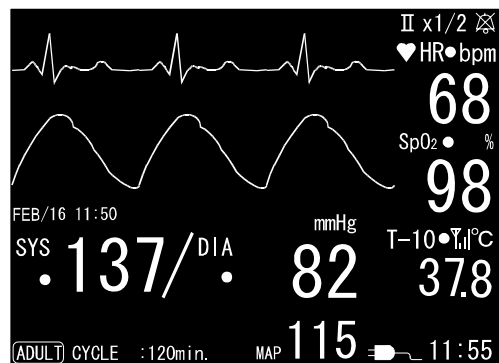

Displays all values in a balanced way

Displayed items depend on the display screen selected. Below is a list of displayed items for each display.

	Home display	Waveform	Blood pressure	Pulse graph	HR/PR SpO <sub>2</sub>	Temperature	Message
1	Blood pressure 2 traces	Two (3.2 seconds)	Large	—	Medium	—	—
2	Waveform 2 traces	Two (4 seconds)	Small	—	Medium	Medium	Available
3	Pulse graph 1 trace	One (4 seconds)	Medium	Available	Large	—	—
4	Temperature 2 traces	Two (3.2 seconds)	Medium	—	Medium	Medium	Available
5	Temperature 1 trace	One (4 seconds)	Medium	—	Large	Small	Available
6	Sleep mode	—	—	—	—	—	—

\* The acronyms used in the display have the following meanings:

SYS: Systolic blood pressure

DIA: Diastolic blood pressure

MAP: Mean arterial pressure

HR: Heart rate

PR: Pulse rate

bpm: Beats per minute

\*"Large", "Medium" and "Small" indicate the comparison of the item indicated in each display. For example, "Middle" of the blood pressure is not the same as "Middle" of the temperature.

\*When the temperature probe ID is set to "OFF", two home displays of "Temperature 2 traces" and "Temperature 1 trace" will not be displayed.

### Note

- A home display other than the sleep mode display will be stored in non-volatile memory if it is left displayed for five seconds. Then, that home display is displayed every time the power is turned on.
- In the sleep mode display, the backlit amount will be reduced after five seconds.
- When a temperature alarm occurs in the display with no temperature display, the display returns to the default display automatically.
- When any key is pressed in the sleep mode display, the display returns to the home display.
- When an alarm occurs in the sleep mode display, the display returns to the home display.
- In the sleep mode display, no buzzer for interval measurement is available.

## Description of the home display

Here, the basic parameters are described as they appear in the home display.

Please note that the composition depends on the instrument model.

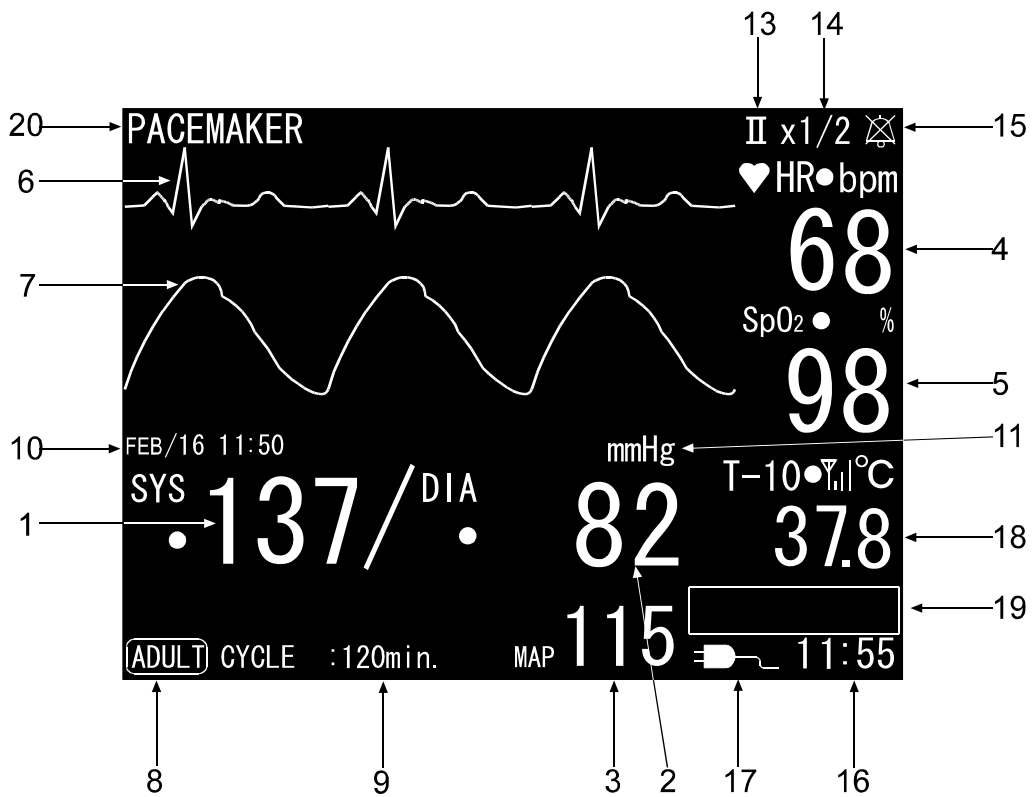

TM-2564G standard home display (Blood pressure 2 traces)

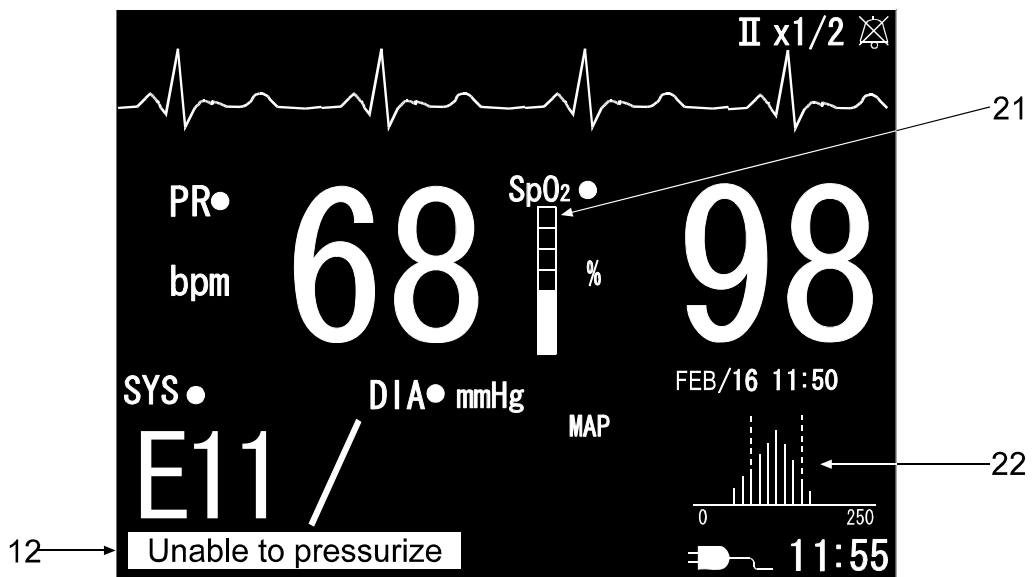

TM-2564G Pulse graph

	Name	Displayed item	Description
1	Systolic blood pressure display	Systolic blood pressure	<ul style="list-style-type: none"> <li>•Displays the value after measurement.</li> <li>•Retained until the next measurement.</li> </ul>
		Systolic blood pressure (When an alarm occurs)	<ul style="list-style-type: none"> <li>•Flashes in red when the limit values are exceeded.</li> <li>•Retained until the next measurement.</li> </ul>
		Blood pressure error	<ul style="list-style-type: none"> <li>•Flashes the error code when an error occurs.</li> <li>•Retained until the next measurement.</li> </ul>
		Quick systolic	<ul style="list-style-type: none"> <li>•Flashes the predicted value during interval measurement.</li> <li>•The value is not monitored by the limit function.</li> <li>•Replaced with the final value after measurement.</li> </ul>
		"SYS"	•Displayed at the upper left side to indicate that the systolic blood pressure value is displayed.
		"●" (Red circle)	•Displays a red circle near "SYS" when the limit values are set.
2	Diastolic blood pressure display	Diastolic blood pressure	<ul style="list-style-type: none"> <li>•Displays the value after measurement.</li> <li>•Retained until the next measurement.</li> </ul>
		Diastolic blood pressure (When an alarm occurs)	<ul style="list-style-type: none"> <li>•Flashes in red when the limit values are exceeded.</li> <li>•Retained until the next measurement.</li> </ul>
		Cuff pressure	•Displays the cuff pressure value during measurement.
		"DIA"	•Displayed at the upper left side to indicate that the diastolic blood pressure value is displayed.
		"●" (Red circle)	•Displays a red circle near "DIA" when the limit values are set.
3	Mean blood pressure display	Mean blood pressure	<ul style="list-style-type: none"> <li>•Displays the value after measurement.</li> <li>•Retained until the next measurement.</li> </ul>
		"MAP"	•Displayed near the value to indicate that the mean blood pressure value is displayed.
4	Heart rate Pulse rate display	Heart rate/Pulse rate	<ul style="list-style-type: none"> <li>•Displays as specified in the function setting. (Refer to "6-14 Function Setting".)</li> <li>When "AUTO" is selected, displays the value according to the order of precedence of ECG, SpO<sub>2</sub> and blood pressure.</li> <li>•When no values are detected, displays the ECG status.</li> <li>Displays " - - - " during pulse detection, and "LF" when the electrode is off the proper site.</li> </ul>
		"HR" / "PR"	<ul style="list-style-type: none"> <li>•Displays "HR" to indicate that heart rate is displayed in ECG measurement.</li> <li>•Displays "PR" to indicate that pulse rate is displayed in SpO<sub>2</sub> or blood pressure measurement.</li> </ul>
		Heart mark	•Flashes in synchronization with the heart rate/pulse rate.
		Heart rate/Pulse rate (When an alarm occurs)	<ul style="list-style-type: none"> <li>•Flashes in red when the limit values are exceeded.</li> <li>•Retained until the value is within the limit values.</li> </ul>
		"bpm"	•Displayed as the unit of heart rate/pulse rate.
		"●" (Red circle)	•Displays a red circle near "HR" or "PR" when the limit values are set.
		Displaying color	<ul style="list-style-type: none"> <li>•Displays the heart rate by the ECG measurement in green.</li> <li>•Displays the pulse rate by the SpO<sub>2</sub> measurement in blue.</li> <li>•Displays the pulse rate by the blood pressure measurement in yellow.</li> </ul>

Continued

5	SpO <sub>2</sub> display	SpO <sub>2</sub> value	<ul style="list-style-type: none"> <li>•Updates the value during measurement.</li> <li>•Displays " - - - " during pulse detection, and "LF" when the sensor is not connected.</li> </ul>
		SpO <sub>2</sub> value (When an alarm occurs)	<ul style="list-style-type: none"> <li>•Flashes in red when the limit values are exceeded.</li> <li>•Retained until the value is within the limit values.</li> </ul>
		"%"	<ul style="list-style-type: none"> <li>•Displayed as the unit of SpO<sub>2</sub>.</li> </ul>
		"●" (Red circle)	<ul style="list-style-type: none"> <li>•Displays a red circle near "SpO<sub>2</sub>" when the limit values are set.</li> </ul>
6	ECG waveform display	ECG waveform	<ul style="list-style-type: none"> <li>•Displays the ECG waveform in the preset sweep rate.</li> <li>•Not available for TM-2560G/TM-2560GP.</li> </ul>
7	Plethysmograph display	Plethysmograph	<ul style="list-style-type: none"> <li>•Displays the SpO<sub>2</sub> plethysmograph in the preset ECG sweep rate.</li> <li>•Two displays for TM-2560G/TM-2560GP. (The sweep rate is fixed to 25 mm/s.)</li> </ul>
8	Patient display	Patient to measure blood pressure	<ul style="list-style-type: none"> <li>•Displays "ADULT" to indicate that the patient whose blood pressure to be measured is adult.</li> </ul>
9	Measuring interval display	Interval to measure blood pressure	<ul style="list-style-type: none"> <li>•Displays the preset blood pressure measuring interval.</li> </ul>
		"CYCLE"	<ul style="list-style-type: none"> <li>•Displayed to indicate that the blood pressure measuring interval is displayed.</li> </ul>
10	Measuring time display	Blood pressure measuring time	<ul style="list-style-type: none"> <li>•Displays the time the blood pressure is measured.</li> </ul>
11	Blood pressure unit display	Blood pressure unit	<ul style="list-style-type: none"> <li>•Displays "mmHg" as the unit of blood pressure.</li> </ul>
12	Error message	Blood pressure measurement error	<ul style="list-style-type: none"> <li>•Displays the error that occurs during blood pressure measurement.</li> </ul>
13	ECG lead display	ECG lead	<ul style="list-style-type: none"> <li>•Displays the preset lead type as "I", "II", or "III".</li> </ul>
14	ECG displaying magnification display	ECG displaying magnification	<ul style="list-style-type: none"> <li>•Displays the preset ECG displaying magnification.</li> </ul>
15	Alarm off mark	Alarm off mark	<ul style="list-style-type: none"> <li>•Illuminates when the ALARM OFF key is pressed to stop the alarm.</li> </ul>
16	Current time display	Current time	<ul style="list-style-type: none"> <li>•Displays the current time.</li> </ul>
17	Power supply display	Power supply	<ul style="list-style-type: none"> <li>•Displays the power currently used.</li> <li>•Displays the remaining battery charge when the battery is used. (Refer to "6-12 Power Supply".)</li> </ul>
18	Temperature display	Temperature probe ID	<ul style="list-style-type: none"> <li>•Displays the preset temperature probe ID as "T-**".</li> </ul>
		Temperature value	<ul style="list-style-type: none"> <li>•Updates during measurement using the temperature probe.</li> <li>•Displays " - - - " when communication with the probe is disconnected.</li> </ul>
		Antenna mark	<ul style="list-style-type: none"> <li>•Displays the communication status by the number of antennas.</li> </ul>
		Temperature value (When an alarm occurs)	<ul style="list-style-type: none"> <li>•Flashes in red when the limit values are exceeded.</li> <li>•Retained until the value is within the limit values.</li> </ul>
		"°C "	<ul style="list-style-type: none"> <li>•Displayed as the unit of temperature.</li> </ul>
		"●" (Red circle)	<ul style="list-style-type: none"> <li>•Displays a red circle near temperature probe display when the limit values are set.</li> </ul>

Continued

19	Message box	Message	•Displays the connection status with the options and other messages.
20	Pacemaker detection	Pacemaker detection	•Displayed when "ON" is selected for pacemaker detection.
21	SpO <sub>2</sub> pulse bar graph display	SpO <sub>2</sub> pulse bar graph	•Displays the bar graph in synchronization with the SpO <sub>2</sub> pulse.
22	Blood pressure pulse graph display	Blood pressure pulse graph	•Displays the pulse graph obtained during blood pressure measurement.

SYS: Systolic blood pressure

DIA: Diastolic blood pressure

MAP: Mean arterial pressure

HR: Heart rate

PR: Pulse rate

bpm: Beats per minute

## 5-2 List Display

When the home display is being shown, press the LIST key (▲ key) to go to the list display.

### Note

- When the list display is being shown, press the HOME key to return to the home display.
- The memory data is erased in the list display. Refer to "6-11 Storing/Deleting data" for details.
- In the list display, after about 5 minutes of inoperation, the latest page will be indicated.

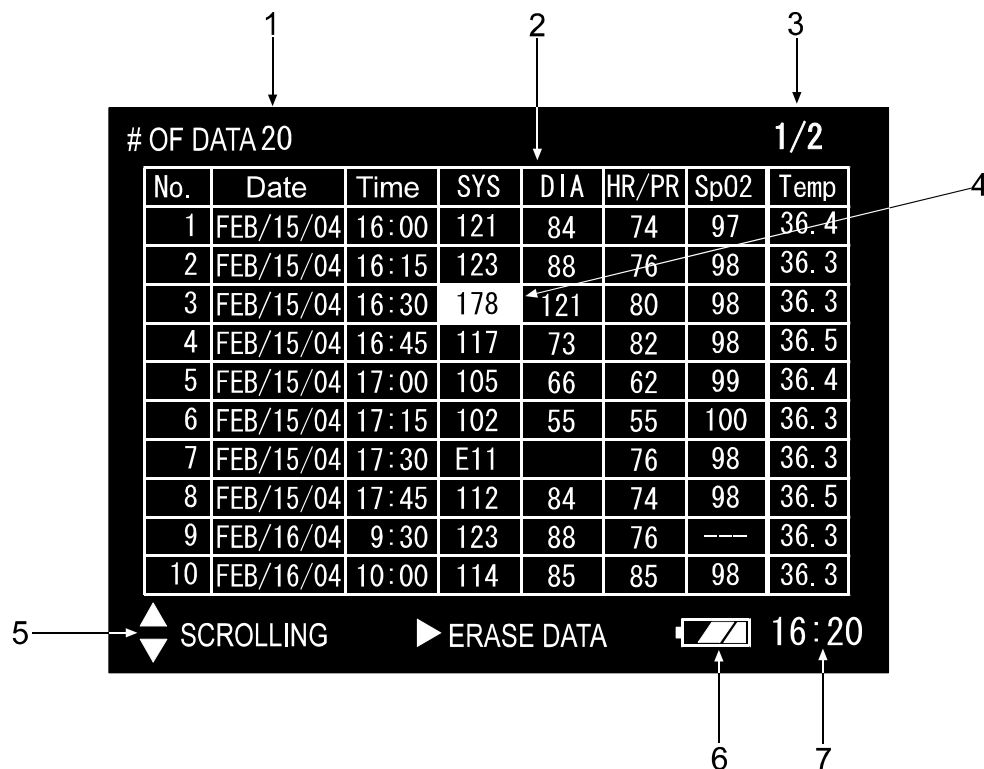

	Name	Displayed item	Description
1	Number of data display	Number of data	•Displays the number of data stored in memory.
2	List display	List of measured values	•Displays the memory data in order of storage. The greater the number is, the newer the data is. •Displays the number, date, and the values of memory data.
3	Page number display	Page number	•Displays the page number/total page to indicate where the displayed data is among the whole data.
4	Alarm display	Alarm	•The value will be highlighted when it exceeds the limit values.
5	Key operation display	Scrolling	•Press the ▲ / ▼ keys to scroll up or down the pages.
		Erase data	•Press the ▶ key to erase the memory data.
6	Power supply display	Power supply type	•Displays the power currently used. •Displays the remaining battery charge when the battery is used. (Refer to "6-12 Power Supply".)
7	Current time display	Current time	•Displays the current time.

## 5-3 Trend Display

When the home display is being shown, press the TREND key (▼ key) to indicate the trend display of the latest 24 hours.

### Note

- When the trend display is being shown, press the HOME key to return to the home display.
- In the trend display, after about 5 minutes of inoperation, the latest page will be indicated.

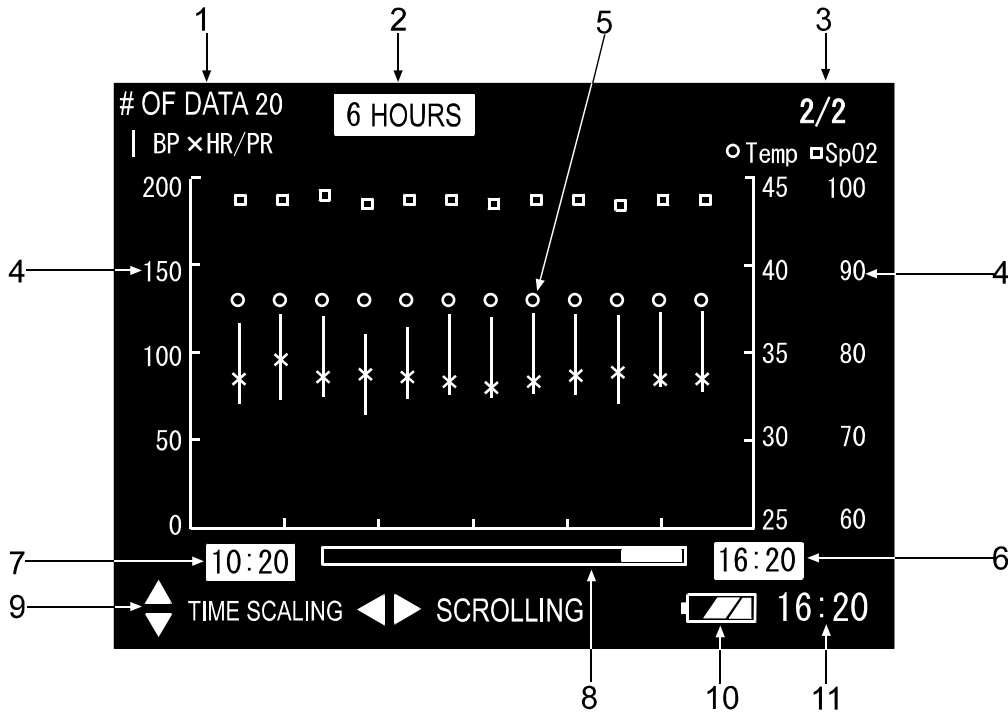

	Name	Displayed item	Description
1	Number of data display	Number of data	•Displays the number of data stored in memory.
2	Time scaling	Trend time width	•Displays the time width of the trend currently displayed.
3	Page number display	Page number	•Displays the page number/total page to indicate where the displayed data is among the whole data.
4	Scale display	Measured values	•Displays blood pressure data in bar graph in the range of 0 to 200 mmHg.
5	Graph display		•Displays SpO <sub>2</sub> data using □ in the range of 60 to 100%.
			•Displays heart rate/pulse rate data using X in the range of 0 to 200 bpm.
6	Trend end time display	Time scaling of the trend display	•Displays the start and end time of the trend.
	7		
8	Scroll bar display	Scroll bar	•Displays the bar graph to indicate where the displayed trend is in the 24-hour scale.
9	Key operation display	Time scaling	•Press the ▲ / ▼ keys to change the time scale. (1, 2, 3, 6, 12, 24 hours).
		Scrolling	•Press the ◀ / ▶ keys to scroll up or down the pages.



10	Power supply display	Power supply type	<ul style="list-style-type: none"> <li>•Displays the power currently used.</li> <li>•Displays the remaining battery charge.</li> </ul>
11	Current time display	Current time	<ul style="list-style-type: none"> <li>•Displays the current time.</li> </ul>

## 5-4 Pause Display

When the home display is being shown, press the PAUSE key to pause the waveform.

### Note

- When the display is paused, press the HOME key or PAUSE key to return to the home display.
- In the Pause display, press the ECG RECORD START/STOP key to print the ECG waveform of 16 seconds occurred right before the PAUSE key is pressed.
- In the pause display, after about 5 minutes of inoperation, the home display will be indicated.

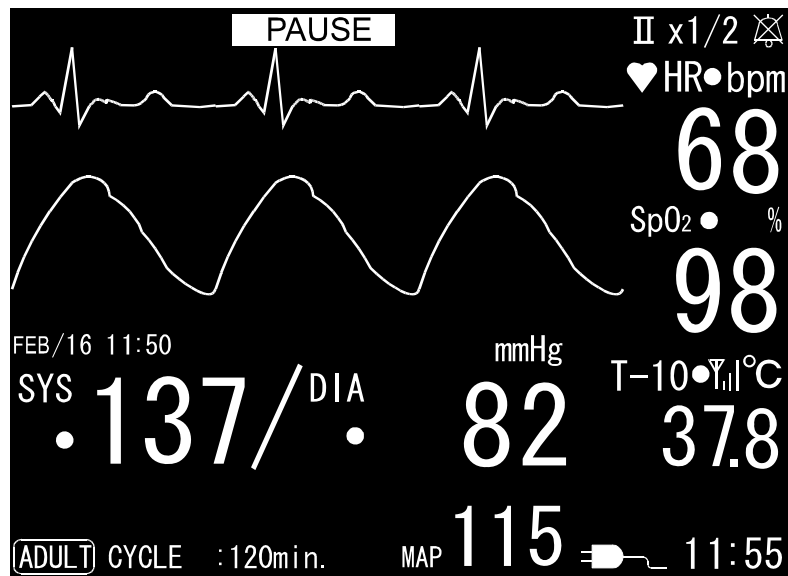

## 5-5 Setting Mode Display

When the home display is being shown, press the MENU key (◀ key) to indicate the setting mode display.

### Note

- When the setting mode display is being shown, press the HOME key to return to the home display.
- The setting mode display of any setting item consists of menu, submenu and the value.

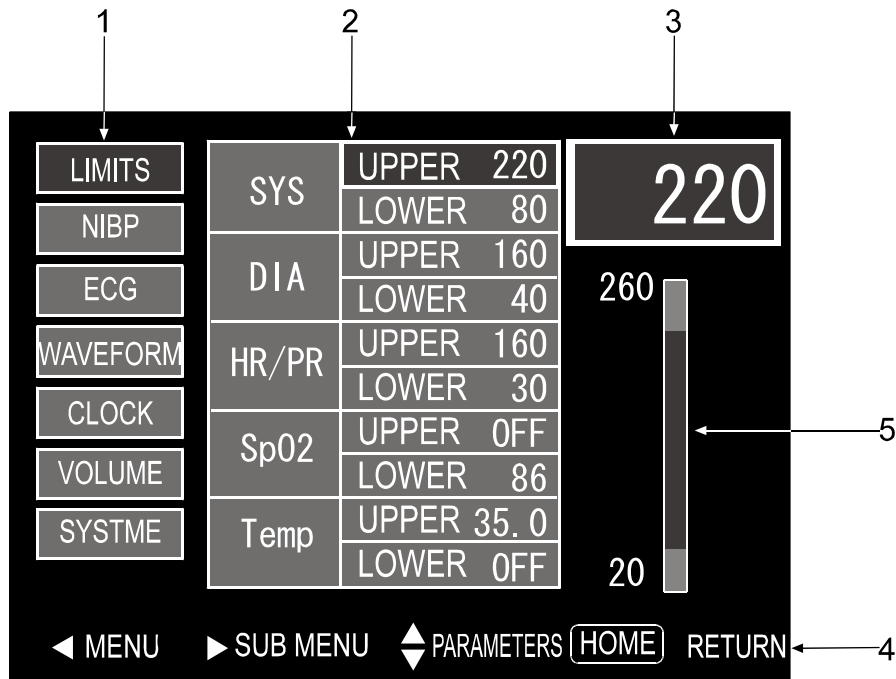

	Name	Displayed item	Description
1	Menu display	Setting menu items	<ul style="list-style-type: none"> <li>•Displays the list of menu items, with one currently selected being highlighted.</li> <li>•Press the ◀ key to select the item to be changed.</li> </ul>
2	Sub menu display	Setting sub menu items	<ul style="list-style-type: none"> <li>•Displays the list of sub menu items corresponding to the selected menu, with one currently selected and its value being highlighted</li> <li>•Press the ▶ key to select the item to be changed.</li> </ul>
3	Set value display	Set value	<ul style="list-style-type: none"> <li>•Displays the set value of the selected item.</li> <li>•Press the ▲ or ▼ key to change the value.</li> </ul>
4	Key operation display	Menu	•Press the ◀ key to select the menu to be set.
		Sub menu	•Press the ▶ key to select the submenu to be set.
		Parameters	•Press the ▲ or ▼ key to change the value.
		Return	•Press the HOME key to quit the setting mode display and return to the home display.
5	Limits bar graph display	Limit values bar graph	<ul style="list-style-type: none"> <li>•Displayed only when the limit values are set.</li> <li>•Displays the upper and lower limit values in bar graph</li> </ul>

## 5-6 Quick Setting Window

When the home display is being shown, press the QUICK SETTING key to open the quick setting window.

### Note

- When the quick setting window is being shown, press the HOME key to close the window. Refer to "6-4 Quick Setting Mode" for details.

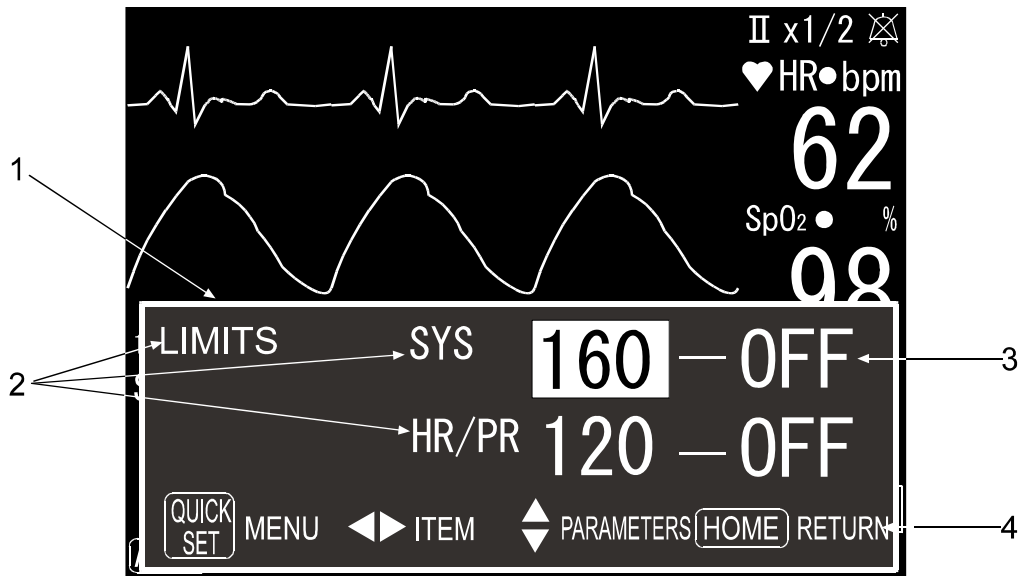

	Name	Displayed item	Description
1	Quick setting window	Quick setting window	<ul style="list-style-type: none"> <li>Sets the items that are changed frequently.</li> <li>Overwritten in the home display.</li> </ul>
2	Setting items display	Setting items	<ul style="list-style-type: none"> <li>Displays the quick setting items corresponding to the menu and sub menu selected in the setting mode display.</li> </ul>
3	Set value display	Set value	<ul style="list-style-type: none"> <li>Displays the currently set value, with one currently selected being highlighted</li> </ul>
4	Key operation display	Menu	<ul style="list-style-type: none"> <li>Press the quick setting key to select the menu to be set.</li> </ul>
		Item	<ul style="list-style-type: none"> <li>Press the ◀ or ▶ key to select the submenu to be set.</li> </ul>
		Parameters	<ul style="list-style-type: none"> <li>Press the ▲ or ▼ key to change the value.</li> </ul>
		Return	<ul style="list-style-type: none"> <li>Press the HOME key to close the quick setting window.</li> </ul>

## 6. Operation

### 6-1 Turning on the POWER switch

Turn the POWER switch on. After several seconds of self-check, the home display appears.

#### Note

- When the self-check detects any error, the error code is displayed. The error code display of some errors is frozen. Refer to "7-6 Error Codes" for how to solve the error.
- The self-check checks the data in memory. The duration of the self-check depends on the number of memory data.

### 6-2 Attaching the Cuff/ECG Electrodes/SpO<sub>2</sub> Sensor

Consider "Safety Precautions" appearing in an earlier part of the instruction manual, when attaching the Cuff/ECG electrodes/SpO<sub>2</sub> sensor.

#### Attaching the cuff

1. Hold the cuff with the hose pointing toward the lower part of the arm.
2. Wrap the cuff around the upper arm, about 3-5 cm above the elbow, with the ARTERY mark on the artery, as shown in the illustration.
3. Allow some slack between the cuff and arm so that a finger or two can be inserted.
4. When the cuff inner end is not within the area labeled RANGE, the cuff size is not appropriate. Replace the cuff.

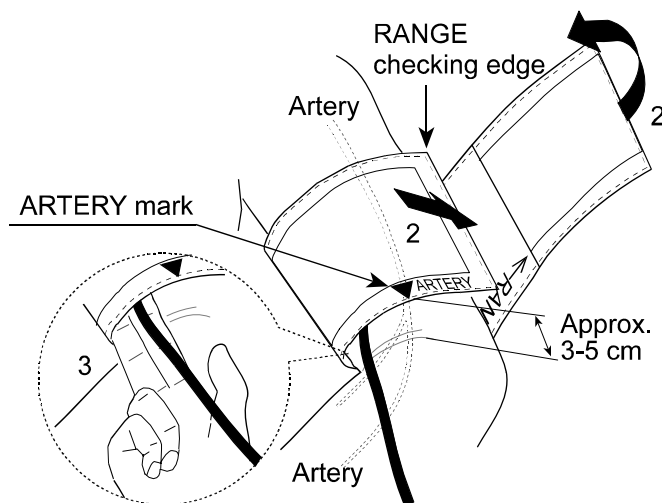

#### Note

- Constriction of the upper arm, caused by rolling up a shirt sleeve, may prevent accurate readings.
- When the size of the supplied cuff does not fit the patient, refer to "8-1 Accessories/Options" to find the proper sized cuff.

## Attaching the ECG electrodes



### Warning

Check the electrode attaching condition in a certain time interval.

If skin integrity changes, move the sensor to another site.



### Caution

- Before attaching the electrodes, use alcohol to clean the body sites where the electrodes are to be attached. Oil or perspiration on the site increases the contact resistance and causes poor contact between electrode and patient.
- Wipe the body sites that are wet with the alcohol, using a clean, dry cotton.
- Do not use the disposable electrode when the paste is dry.

For ECG monitoring, the chest lead configuration as shown below is recommended. It provides the waveform that is similar to that obtained using the standard bipolar limb lead.

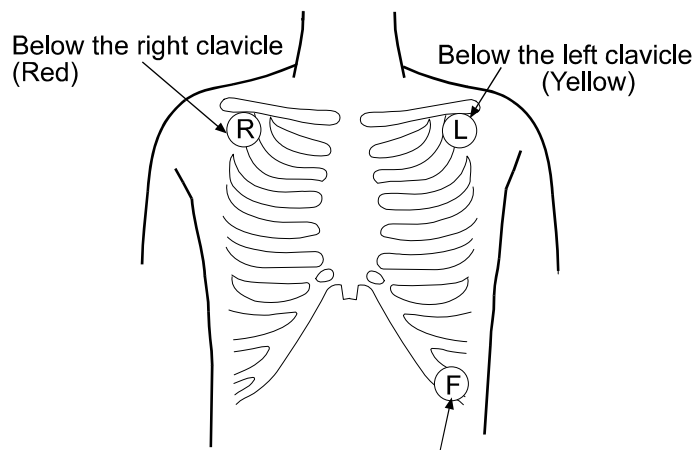

Quasi limb lead using three electrodes

Near the lowest part of the left ribs (Green)

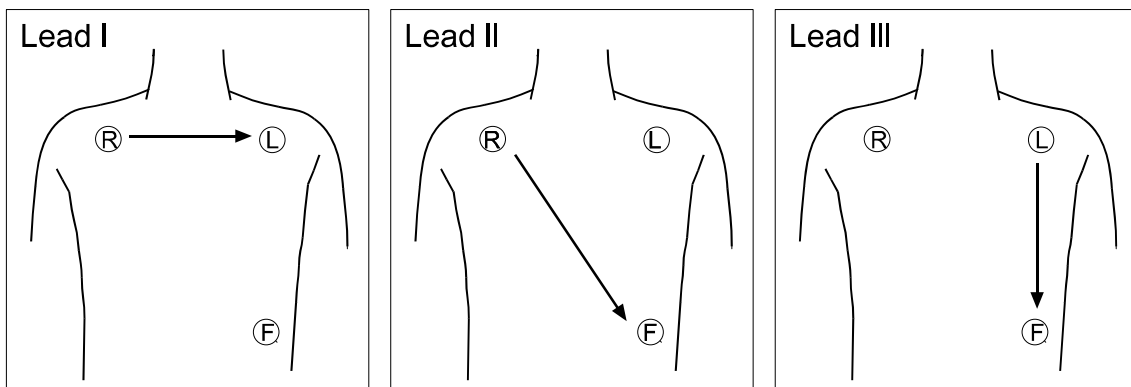

### Note

- To ensure stable monitoring, connect cables firmly and attach the electrodes securely so that they are in good contact throughout monitoring
- Some patients have a weak R-wave pulse. In that case, change the induction method.

## Applying the SpO<sub>2</sub> sensor

Use the sensor appropriate for the patient.

Refer to the instruction manual for each SpO<sub>2</sub> sensor for how to apply the sensor.



### Warning

- Read the SpO<sub>2</sub> sensor instruction manual for proper use.
- Applying the sensor on a body part other than specified or using it longer than specified may cause the patient to suffer physical injury.



### Caution

Do not apply the SpO<sub>2</sub> sensor too tight.

### Note

- Do not apply the sensor on the same arm with an arterial catheter inserted or the cuff attached. Using the same arm will lower the reliability of the measurement data.

## Attaching the temperature probe

The temperature probe and the temperature receiver unit are optional. The temperature receiver unit is to be connected to the OPTION connector.

For how to use them, refer to the relevant instruction manuals.



### Caution

**The temperature probe that can be used with the instrument is of the wireless type. The signal reception condition depends on the environment. Keep it away from electrical noise sources.**

## 6-3 Setting Mode

Here, various setting procedures are described. The items available for setting depends on the model.

### Basic operation

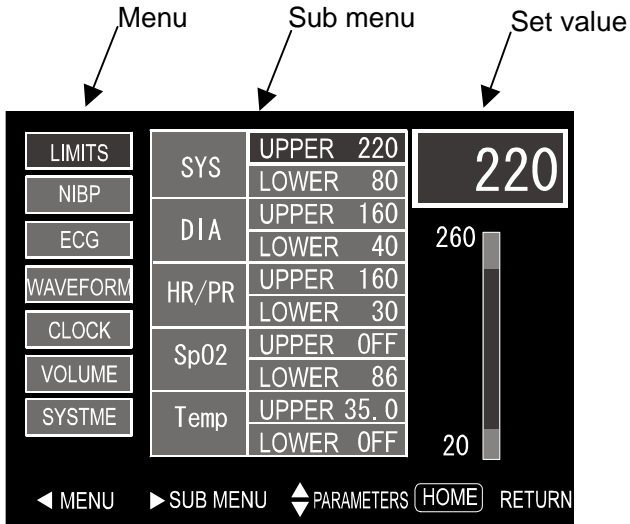

1. In the home display, press the MENU key (◀ key) to indicate the setting mode display..
2. The selected menu and sub menu items are highlighted, and the value of the selected item appears in the box at the upper right corner.

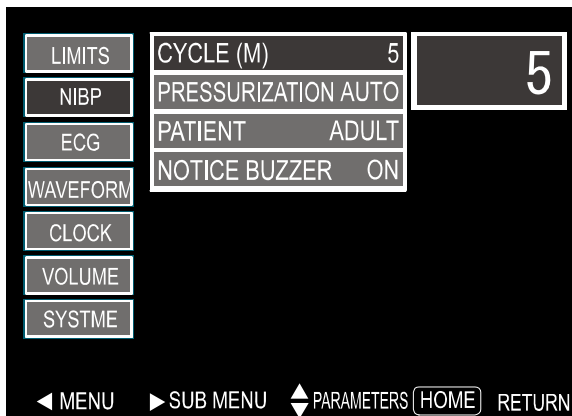

3. Press the ◀ key to go to the next menu.

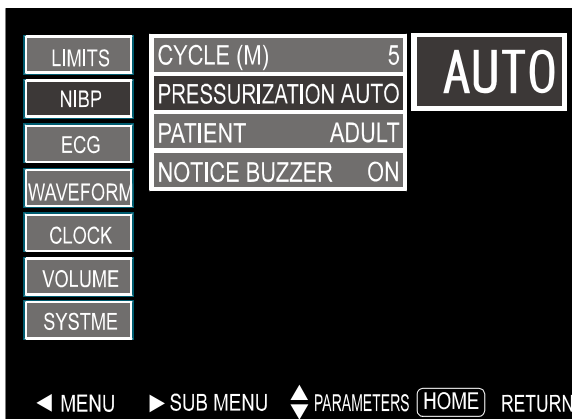

4. Press the ▶ key to go to the next sub menu

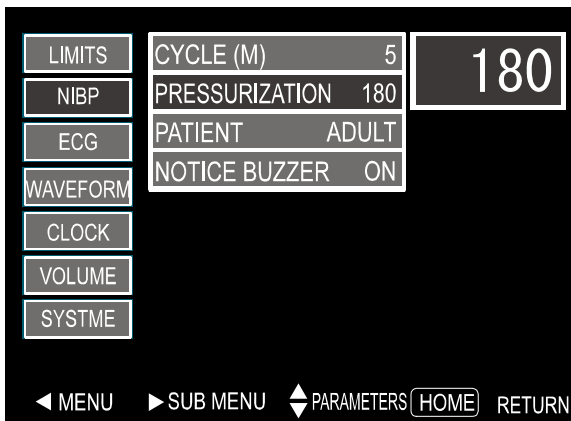

5. Press the ▲ or ▼ key to change the value.
6. The changed value is confirmed when:  
Moved to the next menu or sub menu.  
The HOME key is pressed to return to the home display.

### Note

- In the setting mode display, after about 5 minutes of inoperation, the home display will be indicated.
- When setting the clock, note the following.  
The time in the clock menu indicates that of when the clock menu is displayed, and it remains the same as long as the clock menu is displayed. The actual clock of the instrument continues normal operation. Changing any item of the clock menu is reflected and resets the clock.
- When an alarm occurs, the display will return to the home display.

### Setting items

Menu	Sub menu	Setting range	Unit	Description	
Limits	SYS	Upper	OFF, 50-250 (by 10), <u>200</u>	mmHg	Sets the limit values for alarm.  <b>Note</b> When the lower limit value for SpO <sub>2</sub> measurement has been set to be less than 85%, it will be reset to the default setting upon power-on.
		Lower	OFF, 30-200 (by 10), <u>70</u>		
	DIA	Upper	OFF, 30-200 (by 10), <u>150</u>		
		Lower	OFF, 10-200 (by 10), <u>40</u>		
	HR/PR	Upper	OFF, 50-220 (by 10), <u>170</u>	bpm	
		Lower	OFF, 30-150 (by 10), <u>40</u>		
	SpO <sub>2</sub>	Upper	<u>OFF</u> , 75-99 (by 1)	%	
		Lower	OFF, 50-99 (by 1), <u>85</u>		
Temp	Upper	<u>OFF</u> , 30-44 (by 0.5)	°C		
	Lower	<u>OFF</u> , 26-40 (by 0.5)			
NIBP	Cycle	<u>OFF</u> , CON, 2.5, 3, 5, 10, 15, 20, 30, 60, 90, 120	min	Sets the cycles for interval measurement.	
	Pressurization	<u>AUTO</u> , 100-260 (by 20)	mmHg	Sets the pressurization value for blood pressure measurement. "AUTO": Detects the pulse at the start of pressurization to pressurize properly. During interval measurements, "AUTO" is used.	
	Patient	<u>Adult</u> , Neonate	—	"Adult": Other than neonates	
	Notice buzzer	<u>OFF</u> , ON	—	"ON": Sounds a buzzer 15 seconds before starting an interval measurement.	

Underlined items: Default settings



Continued

ECG	Gain	x1/2, <u>x1</u> , x2, x4	—	Sets the display gain of the ECG waveform.
	Time base	6.25.12.5, <u>25.0</u>	mm/s	Sets the sweep rate of the ECG waveform. Also applied to the plethysmograph.
	Lead	I, <u>II</u> , III	—	Sets the ECG lead.
	Hum filter	OFF, <u>ON</u>	—	Set the ON/OFF of the hum filter of the ECG unit.
	Return time	<u>0.5</u> , 3.2	s	Sets the time constant of the ECG unit.
	Pacemaker	ON, <u>OFF</u>	—	"ON": Highlights the pacemaker in the ECG waveform and prevents mis-counting of the heart rate by the pacemaker. "OFF" is selected upon power-on.
Waveform	Upper	<u>ECG</u> , SpO <sub>2</sub>	—	Sets the waveform displayed at the upper area.
	Lower	ECG, <u>SpO<sub>2</sub></u>		Sets the waveform displayed at the lower area.
Clock	Year	2000-2099		Sets the clock.
	Month	1-12		
	Day	1-31		
	Hour	0-23		
	Minute	00-59		
Volume	Alarm sound	1-4 ( <u>2</u> )	—	Sets the alarm buzzer volume
	Click sound	0-4 ( <u>2</u> )		Sets the key click volume
	Pulse sound	0-4 ( <u>2</u> )		Sets the pulse detection buzzer volume.
System	Storage cycle	<u>OFF</u> , 1, 2, 2.5, 3, 5, 10, 15	min	Sets the memory interval to store the values except blood pressure. Blood pressure values are stored each time they are measured, regardless of this setting.
	Temp. probe	<u>OFF</u> , 1-10	—	Sets the temperature probe ID used.
	Display	<u>ON</u> , OFF	—	"OFF": Does not display the measurement values.
	Brightness	10-100% ( <u>60%</u> ) (by 5)	%	Sets the brightness of the backlight.
	Auto print	OFF, <u>list</u> , graph, trend	—	Sets the auto printing.

Underlined items: Default settings

## 6-4 Quick Setting Mode

Here, the quick setting mode is described, to change the values that are frequently used, or to change the values while watching the waveform. The items available for setting depend on the model.

### Basic operation

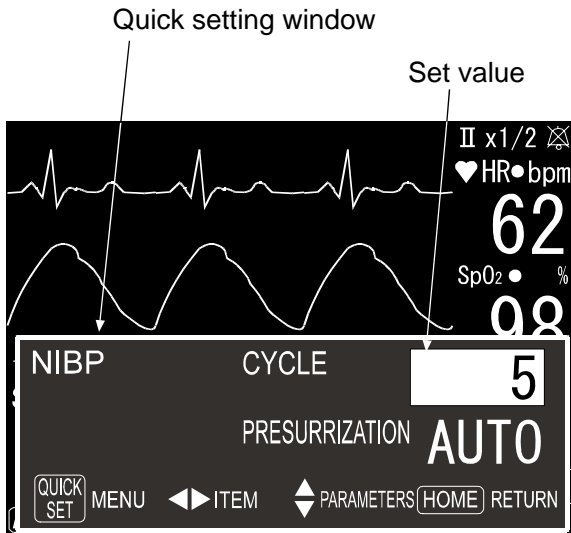

1. In the home display, press the QUICK SETTING key.
2. The quick setting window opens and the selected value is highlighted.

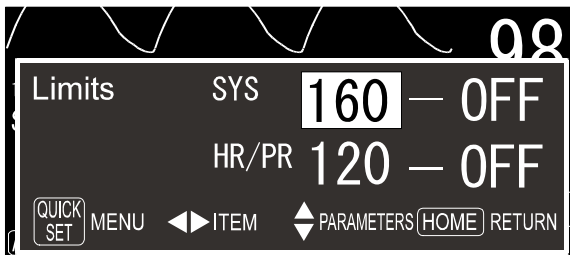

3. Press the QUICK SETTING key to open the next menu.

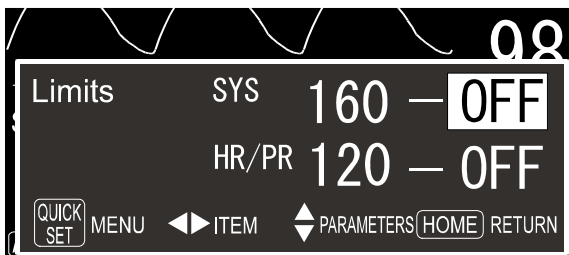

4. Press the or key to select the item.

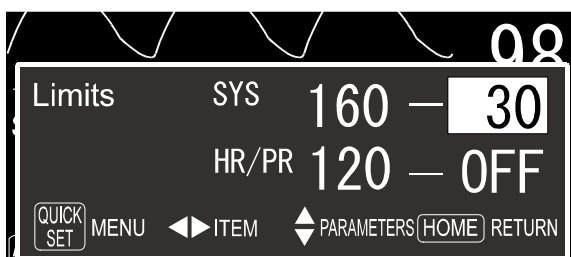

5. Press the or key to change the value.
6. The changed value is confirmed when:  
Moved to the next window or other time.  
The HOME key is pressed to return to the home display.

Menu	Sub menu		Setting range	Unit	Description
NIBP	Cycle		<u>OFF</u> , CON, 2.5, 3, 5, 10, 15, 20, 30, 60, 90, 120	min	Sets the cycles for interval measurement.
	Pressurization		<u>AUTO</u> , 100-260 (by 20)	mmHg	Sets the pressurization value for blood pressure measurement. "AUTO": Detects the pulse at the start of pressurization to pressurize properly. During interval measurements, "AUTO" is used.
Limits	SYS	Upper	<u>OFF</u> , 50-250 (by 10)	mmHg	Sets the limit values for alarm.
		Lower	<u>OFF</u> , 30-200 (by 10)		
	HR/PR	Upper	<u>OFF</u> , 50-220 (by 10)	bpm	
		Lower	<u>OFF</u> , 30-150 (by 10)		
ECG	Gain		x1/2, <u>x1</u> , x2, x4	—	Sets the display gain of the ECG waveform.
	Time base		6.25.12.5, <u>25.0</u>	mm/s	Sets the sweep rate of the ECG waveform. Also applied to the plethysmograph.

Underlined items: Default settings

## 6-5 Measuring the Blood Pressure



### Caution

If the instrument malfunctions during measurement, for example, the air is not exhausted, remove the cuff from the patient immediately.

### Blood pressure measuring procedure

1. Press the NIBP START/STOP key to start a measurement.
2. When "AUTO" is selected for pressurization, the cuff pressure is adjusted automatically to the patient's blood pressure value. Otherwise, the cuff is pressurized to the set value.
3. After measurement, the air is rapidly exhausted from the cuff and the measurement values are displayed. When the pulse rate by the ECG or SpO<sub>2</sub> unit is not available, the pulse rate obtained by blood pressure measurement is displayed.
4. When the blood pressure can not be detected, the measurement is repeated three times.

### Note

- Make sure that the cuff is at the same level as the patient's heart.
- Advise the patient to sit comfortably and relax, remain still and keep quiet during measurement.
- To cancel a measurement that is in progress, press the NIBP START/STOP key.
- When an error occurs during measurement, the error code appears in the SYS display and the error message appears at the bottom of the display.

## Interval measurement

1. Set the cycle to a value other than "OFF".
2. "CYCLE:\*\*\*" appears at the bottom of the home display and starts the interval measurement.
3. Blood pressure starts to be measured at the exact-time synchronized with the built-in clock.
4. To end the interval measurement, set the cycle to "OFF".

### Note

- During interval measurement, pressurization is performed by "AUTO".
- While in the interval measurement mode, blood pressure can be measured at any time by pressing the NIBP START/STOP key.
- When the notice buzzer is set to "ON", the buzzer sounds 15 seconds before the interval measurement starts.

## Continuous measurement

1. Set the cycle to "CON".
2. "CYCLE: CON" appears at the bottom of the home display and starts the continuous measurement after 10 seconds.
3. After 5 minutes, the continuous measurement switches to the 5-minute interval measurement, and the display switches from "CYCLE: CON" to "CYCLE: C-5".
4. To perform the continuous measurement again, go to the setting mode to set the cycle to "CON".

## Quick systolic display

During interval measurement, the predicted systolic blood pressure flashes. It is replaced with the measured value after measurement

## 6-6 Measuring the ECG

---

1. Turn on the POWER switch to start the ECG measurement.
2. Set the conditions appropriate for measurement.

### Note

- The instrument performs real-time detection of the QRS wave, measures the RR interval, and converts it into the heart rate.
- It may take about 10 seconds to display the heart rate after attaching the ECG electrodes.
- Some patients have a weak R-wave pulse. In that case, change the induction method.

## 6-7 Measuring the SpO<sub>2</sub>

---

1. Turn on the POWER switch to start the SpO<sub>2</sub> measurement.

### Note

- In SpO<sub>2</sub> measurement, the function of automatically compensating the LED to obtain suitable emission for the patient works. Thus, it may take approximately 30 seconds to display the measured value.
- Do not apply the sensor on the same arm with the cuff attached. SpO<sub>2</sub> may not be measured correctly during blood pressure measurement.

## 6-8 Measuring the Temperature (Optional)

---

1. Set the temp. probe to be used.
2. The instrument starts to receive the signal from the wireless temperature probe. Refer to the instruction manuals of the temperature probe and the temperature receiver unit for details.

### Note

- The communication status is displayed by the antenna mark.

## 6-9 Measuring the Heart Rate/Pulse Rate

---

The heart rate and pulse rate are measured in three ways, using the instrument.

The values are displayed according to the order of precedence of ECG, SpO<sub>2</sub> and blood pressure

The heart mark starts to flash and the sound is generated to synchronize the pulse detection.

### Note

- The heart rate/pulse rate is displayed in different colors to indicate what measures the value.  
Green = ECG , Blue = SpO<sub>2</sub>, Yellow = blood pressure
- The synchronized sound can be turned off by the volume setting.
- The heart rate/pulse rate measurement can be specified in the function setting. Refer to "6-14 Function Setting".

## 6-10 Alarm Function

---



- When the limit values are set, the limit mark appears in red as shown in the illustration.
- When the measurement value exceeds the upper or lower limit value, the value and the alarm lamp flash, and the alarm buzzer sounds.
- The alarm buzzer can be stopped by pressing the ALARM OFF key. At this time, the alarm lamp switches from flashing to illuminated constantly

### Warning

- The alarm, which occurs during blood pressure measurement, will be stopped by pressing the ALARM OFF key, or when the next measurement starts.
- The alarm, which occurs during ECG, SpO<sub>2</sub> or temperature measurement, will be stopped by pressing the ALARM OFF key. If the condition that caused the alarm persists after two minutes, the alarm will sound again. (The ALARM OFF mark illuminates while the alarm is stopped.)

## 6-11 Storing/Deleting Data

---

### Note

- The number of data to be stored is 400. Once exceeded, the older data will be erased to store the newer data.

### Storing the data

Data (date, systolic/diastolic blood pressure, heart rate/pulse rate, SpO<sub>2</sub> value and temperature) is stored each time a measurement is performed.

### Storing the data using the storage cycle

When the storage cycle is set, the data (date, heart rate/pulse rate, SpO<sub>2</sub> value and temperature) is stored automatically at the set interval.

### Note



- When the storage cycle is set, the memory function is working while the POWER switch is turned on. Set the storage cycle to "OFF" when the memory function is not necessary.

## Deleting the data



# OF DATA 20 1/2

No.	Date	Time	SYS	DIA	HR/PR	SpO2	Temp
1	FEB/15/04	16:00	121	84	74	97	36.4
2	FEB/15/04	16:15	123	88	76	98	36.3
3	FEB/15/04	16:30	178	121	80	98	36.3
4	FEB/15/04	16:45	117	73	82	98	36.5
5	FEB/15/04	17:00	105	66	62	99	36.4
6	FEB/15/04	17:15	102	55	55	100	36.3
7	FEB/15/04	17:30	E11		76	98	36.3
8	FEB/15/04	17:45	112	84	74	98	36.5
9	FEB/16/04	9:30	123	88	76	—	36.3
10	FEB/16/04	10:00	114	85	85	98	36.3

◀ SCROLLING    ▶ ERASE DATA    🔋 16:20

1. In the home display, press the  key to go to the list display.
2. Press the  key to indicate the memory deletion display.



3. Press the  key to cancel the deletion and return to the list display.
4. Press the  key to perform deletion. After deletion, the list display appears.







**Caution**

**When deleting the data, use much care not to delete important data.**

## 6-12 Power Supply

---

The power supply information, as shown below, appears at the lower right side of the display.

Power supply symbol	Description
	The instrument is working on the AC adapter.
	The instrument is working on the battery. <ul style="list-style-type: none"><li>• The battery charge is full.</li></ul>
	The instrument is working on the battery. <ul style="list-style-type: none"><li>• The battery charge has decreased. Charging is required soon.</li></ul>
	The instrument is working on the battery. <ul style="list-style-type: none"><li>• The battery charge has been drained. Charging is required immediately.</li></ul>

### Note

- When the instrument detects the decrease of the battery capacity, the battery mark flashes and the buzzer sounds.

## 6-13 Printing the Measurement Data

---



### Caution

Cutting the paper forcibly or during printing may damage the print head.

### Auto printing

- When "List" or "Trend" is selected for "Auto print" in the setting mode, printing is performed automatically each time blood pressure is measured and at the preset storage cycle. Printing at the storage cycle is not available when the storage cycle is set to "OFF".
- When "Graph" is selected for "Auto print" in the setting mode, printing is performed automatically each time blood pressure is measured.

### Memory printing

- When the LIST key is pressed in other than the list display, a maximum of 10 of the newest data in the list display is printed.
- When the LIST key is pressed in the list display, a maximum of 10 data displayed in the list display is printed.
- When the LIST key is pressed and held for 3 seconds or more in any display, all the data stored in memory is printed.
- To cancel the on-going printing, press the LIST key.



## Printing the ECG waveform

- When the ECG RECORD START/STOP key is pressed in other than the setting mode display, an ECG waveform of 16 seconds is printed. It takes about 30 seconds to print it out.
- With the waveform, the date, time and HR (heart rate), taken when the ECG RECORD START/STOP key is pressed, is printed.
- The waveform for calibration is printed at the beginning and end of the waveform data. (The waveform for calibration indicates that for 1mV.)
- The printing speed is fixed to 25mm/sec. And the printing is performed at the same gain as the display gain.
- To cancel the on-going printing, press the ECG RECORD START/STOP key.

## Print sample

Name					
June 8, 2004					
		HIGH	LOW		
SYS	LIMIT	160	OFF		
DIA	LIMIT	OFF	OFF		
PUL	LIMIT	180	OFF		
SpO <sub>2</sub>	LIMIT	OFF	OFF		
TEMP	LIMIT	40.0	OFF		
TIME	SYS	DIA	PUL	SpO <sub>2</sub>	TEMP
	mmHg		bpm	%	°C
10:10	121	84	74	97	36.4
10:20	123	88	76	98	36.3
10:30	<b>178</b>	121	80	98	36.3
10:40	117	73	82	98	36.5
10:50	105	66	62	99	36.4
11:00	102	55	55	100	36.3
11:10	E11		76	98	36.3
11:20	112	84	74	98	36.5
11:30	123	88	76	—	36.3
11:40	114	85	85	98	36.3

### List printing

- Prints the measurement data in tabular form.
- Highlights the alarmed data.

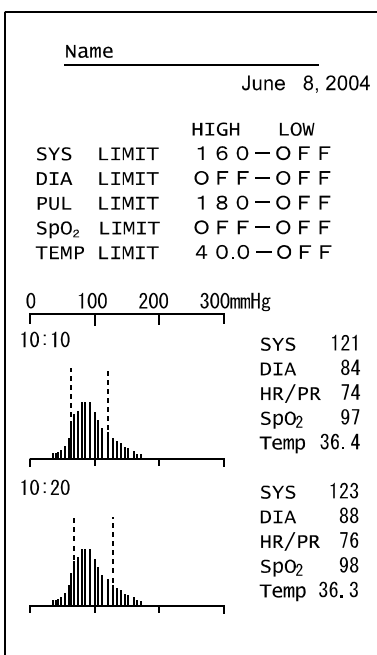

### Graph printing

- Prints the measurement data in graph form.
- Highlights the alarmed data.
- The dotted lines indicate the systolic and diastolic blood pressures.

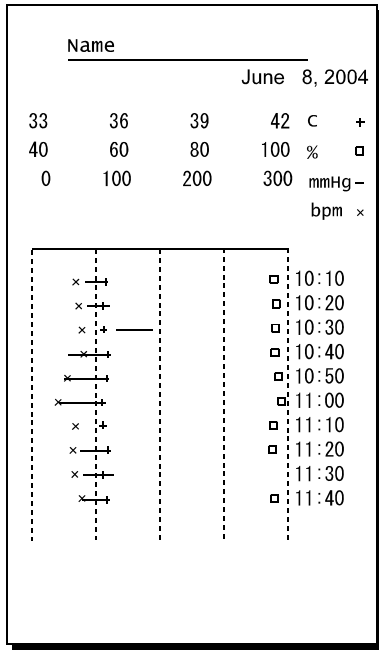

### Trend printing

- Prints the measurement data in trend form, using the symbols below:
  - = Systolic, Diastolic
  - = SpO<sub>2</sub>, x = heart rate/pulse rate, + = temperature

### ECG waveform

June 8, 2004 15:22 SPEED 25mm/sec  
HR = 80 bpm GAIN X1



## 6-14 Function Setting

Here, the function setting procedure is described.

### Note

- The settings can be changed to suit to the operating environment.
- Turning off the POWER switch during the setting operation will cancel the operation.

### Setting procedure

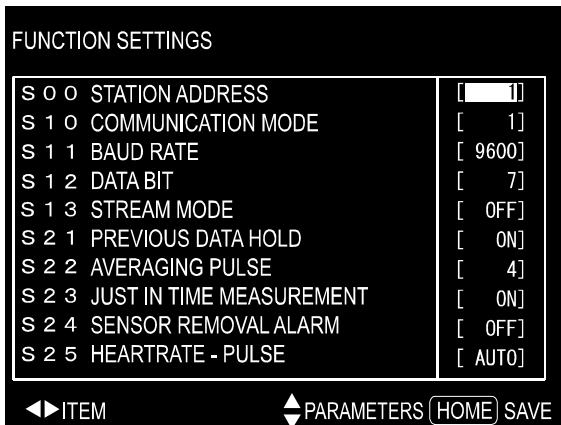

1. While holding down the QUICK SETTING key, turn on the POWER switch to indicate the function setting display. The selected item is highlighted.

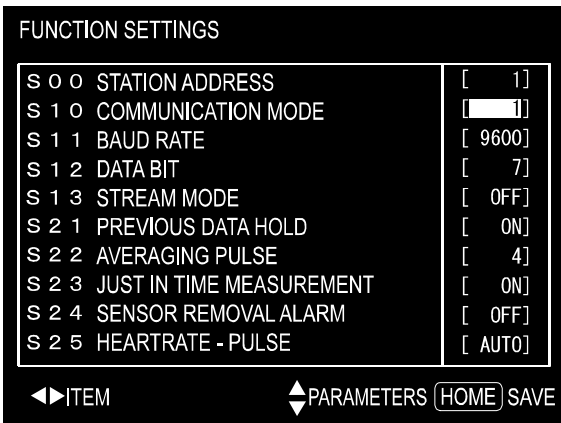

2. Press the ◀ or ▶ key to select the item.

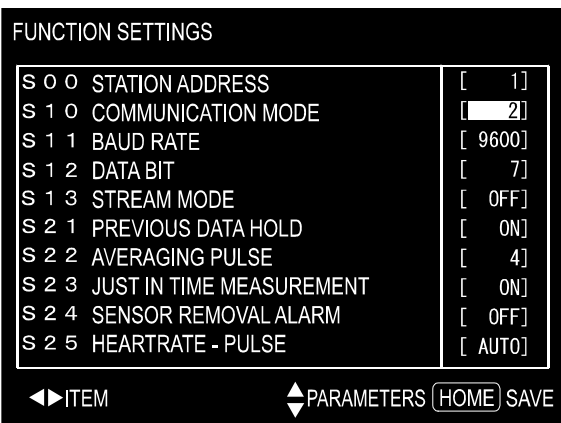

3. Press the ▲ or ▼ key to change the value.
4. Press the HOME key to store the setting. "Now saving" appears, and then the display returns to the previous display.
5. Turn off the POWER switch. Next time the POWER switch is turned on, the instrument functions as specified in the system settings.

No.	Setting item	Setting range	Description
S00	Station address	0-98 ( <u>0</u> )	To connect an option.
S10	Communication mode	1-10 ( <u>1</u> )	To connect an option. To be selected, depending on the option.
S11	Baud rate	1200, 2400, 4800, <u>9600</u> , 19200, 38400	To connect an option. To be selected, depending on the option
S12	Data bit	<u>7</u> , 8	To connect an option. To be selected, depending on the option
S13	Stream mode	<u>OFF</u> , ON	To connect an option. To be selected, depending on the option
S21	Previous data hold	OFF, <u>ON</u>	Whether to retain the previous data or not when the POWER switch is turned off. "ON" to retain.
S22	Averaging pulse	1, <u>4</u> , 8	Sets the number of ECG pulse rate data for moving average.
S23	Just in time measurement	OFF, <u>ON</u>	Whether to use an exact-time measurement for blood pressure or not. "ON" to use.
S24	Sensor removal alarm	<u>OFF</u> , ON	Whether to sound an alarm when the sensor removal is detected. "OFF" not to sound.
S25	Heart rate -pulse	<u>AUTO</u> , ECG, SpO <sub>2</sub> , NIBP	Specifies whether to display, heart rate or pulse rate and pulse sound. "AUTO" to sound pulse in synchronization with the pulse detected according to the order of precedence.

Underlined items: Default settings

# 7. Maintenance

## 7-1 Cleaning

---



### Caution

- Before cleaning, turn off the power and remove the AC adapter.
- Do not pour water on the instrument or use water for cleaning. This instrument is not waterproof.
- Do not sterilize the instrument by gaseous sterilization or using an autoclave.
- Do not use solvents such as thinner and benzene for cleaning. That may deform or discolor the instrument.

Clean the instrument as described below:

- Clean the instrument exterior with a dry soft cloth.
- If the instrument is stained with blood, chemical substance, or dirt, wipe the instrument off using a cloth dampened with a mild detergent.

For cleaning a patient's body site to apply a sensor, follow the procedure of each hospital.

- To disinfect the cuff, wipe the surface which comes into contact with the skin with alcohol such as 70% isopropyl. Do not wash the cuff.
- Discard the disposables after use. To disinfect the optional SpO<sub>2</sub> sensor or the extension cable, use alcohol such as 70% isopropyl or bleach diluted by 10%.
- Wipe the ECG extension cable and ECG patient cable with alcohol such as 70% isopropyl.

## 7-2 Calibration

---

This is a precision instrument. Perform a checkup periodically.

### Checking the pressure accuracy

Connect the pressure generator and the manometer to the instrument as shown in the illustration.

Use the optional 500-cc cylinder or the cuff wrapped loosely around a cylinder.

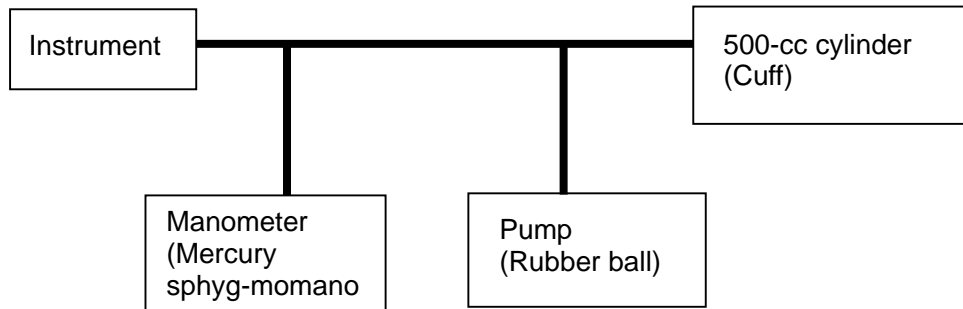

While holding down the HOME key, turn on the POWER switch. "M01" appears at the upper left of the display.

Press the NIBP START/STOP key to be in the pressure calibration mode. The pressure value appears in the SYS/DIA display. Pressurize to 200 mmHg, and then 100 mmHg, using the pump. Compare the value displayed on the instrument with the pressure displayed on the manometer. The difference should be within  $\pm 4$  mmHg.

Turn off the POWER switch.

### Checking the exhaustion speed

Connect the optional 500-cc cylinder or the equivalent to the instrument as shown in the illustration.

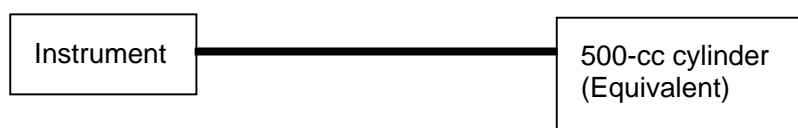

While holding down the HOME key, turn on the POWER switch. "M01" appears at the upper left of the display. Press the  key to display "M02".

Press the NIBP START/STOP key to start constant exhaustion. The pressure value appears in the middle left display and the exhaustion speed in the lower display. The exhaustion speed displayed after checking should be  $50 \pm 20$  ( $5.0 \pm 2.0$  mmHg/sec).

Turn off the POWER switch.

If the accuracy can not be obtained, contact your nearest A&D sales representative for inspection.

## 7-3 Assembling the Cuff

---

### Replacing the cuff cloth

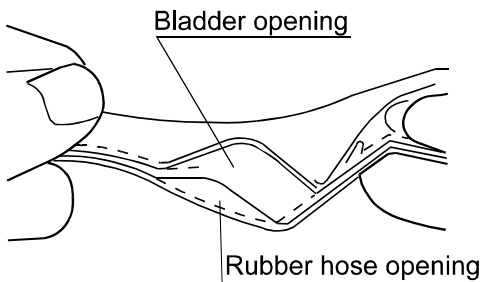

Insert the rubber hose completely into the cuff cloth. From the bladder opening, pull out the bladder with the rubber hose.

After replacing the cuff cloth, put back the bladder and the rubber hose through the bladder opening. Pull out the rubber hose through the rubber hose opening.

Be sure to pull out all of the rubber hose. Otherwise, when pressurized, the bladder may inflate at the opening and burst.

## 7-4 Disposing of the Instrument

---

When recycling or disposing of the instrument, follow the local regulations.

### Battery

When disposing of the used battery, insulate the battery lead connector with tape and follow the local regulations.

### Cuffs and sensors

The cuffs and sensors used by the patient may cause infection. Dispose of them as medical waste.

### Built-in lithium battery

When disposing of the instrument, remove the built-in lithium battery.

When disposing of the battery, insulate it with tape and follow the local regulations.

## 7-5 Before Asking for a Repair

---

Before asking for a repair, check the instrument error codes in "7-6 Error Codes" or read "Appendix A: Measuring Principle" to see whether the measurement was performed correctly.

If normal operation of the instrument cannot be recovered even after these actions have been taken, contact the agent where you purchased the instrument or the nearest A&D sales representative.



**Caution**

**Only qualified service personnel are allowed to open the case to repair the instrument.**

**Do not attempt to open the instrument.**

## 7-6 Error Codes

When the instrument detects an erroneous measurement condition, the following error codes are displayed.

Error code	Symptom	Remedy
<b>Blood pressure related errors</b>		
E00	Zero point error in the pressure sensor circuit	Exhaust air from the cuff and turn on the power again.
E11	Can not pressurize.	Check the cuff and hose for correct connection or check them for being folded.
E12	Pressurizing speed is too slow.	
E13	Pressurizing speed is too fast.	Confirm that the patient setting is correct. (Adult, Neonate)
E21	Measurement time is too long. Constant exhaustion speed is too slow.	Check the cuff and hose for correct connection or check them for being folded.
E22	Exhaustion speed is too fast.	
E23	Excessive pressure is detected.	
E42	Insufficient pressurization	Check the cuff for correct placement or check the patient for physical movement or for irregular pulse.
E43	No pulse is detected.	
E44	Physical movement is detected.	
E45	The diastolic blood pressure cannot be determined.	
E46	The mean blood pressure cannot be determined.	
E48	The systolic blood pressure cannot be determined	
E61	The pulse rate cannot be determined.	
E63	The blood pressure value is inappropriate.	
<b>SpO<sub>2</sub> related errors</b>		
E30	SpO <sub>2</sub> self test error	Turn on the power again.
E31	SpO <sub>2</sub> sensor error	Confirm that the specified sensor is connected.
<b>ECG related errors</b>		
E35	ECG self test error	Turn on the power again.
E36	Defective ECG circuit	
<b>Other error</b>		
E80	System error	Turn on the power again.

### Note

- Cuffs and sensors are consumables. If a measurement error occurs frequently, they must be replaced. Refer to "8 Accessories/Options" for detail information.
- When the optional expansion box is connected, error codes other than listed in the table may appear. Refer to the expansion box instruction manual for details.



## 8. Accessories/Options

Item		Type
Cuff (without hose)		
Disposable type	Neonate 10 pcs. 2 cm wide	TM9155
	Neonate 10 pcs. 3 cm wide	TM9156
	Neonate 10 pcs. 4 cm wide	TM9157
	Neonate 10 pcs. 5 cm wide	TM9158
Infant	Arm circumference 7-12 cm	TM9114B-1
Child	Arm circumference 10-17 cm	TM9116B-1
Small	Arm circumference 15-22 cm	TM9113B-1
Adult	Arm circumference 20-31 cm	TM9112B-1
Large	Arm circumference 31-41 cm	TM9111B-1
Spare cuff cloth 2 pcs./set (For TM9112B-1)		AX-13A37452-S
Hose (with connector)		
1.5 m		TM9131-150
2.0 m		TM9131-200
2.0 m for neonates		TM9131UN-200
3.5 m for neonates		TM9131UN-350
ECG related		
ECG electrode (150 pcs.)		AX-10502P30-S
ECG patient cable		AX-KO1924
ECG extension cable		AX-KO1839
SpO <sub>2</sub> related		
Durasensor (Finger clip)		AX-SPDS-100A
Oxiband (Adult / Neonate)		AX-SPOXI-A/N
Oxiband (Pediatric / Infant)		AX-SPOXI-P/I
Oxisensor (Adult disposable sensor)		AX-SPMAX-A-S
Oxisensor (Pediatric disposable sensor)		AX-SPMAX-P-S
Oxisensor (Infant disposable sensor)		AX-SPMAX-I-S
Oxisensor (Adult / Neonate disposable sensor)		AX-SPMAX-N-S
Oxisensor (Nasal disposable sensor)		AX-SPMAX-R-S
Dura-Y sensor		AX-SPD-YS
Extension cable (1.2 m)		AX-SPDEC4
Extension cable (2.4 m)		AX-SPDEC8
Temperature related		
Temperature receiver unit		TM2560G-10
Temperature probe (Body surface type)		TM2560G-12
Temperature probe (Axillary type)		TM2560G-11
Power supply		
AC adapter		AX-TB223
Battery		AX-HHR-21HL24G1
Printer paper		
Graph (5 rolls/set)		AX-PP157-S
White (5 rolls/set)		AX-PP132-S
Other		
Table		TM2560G-03

# Appendix A: Measuring Principle

## A-1 Blood Pressure

### Measuring principle

Wrap the cuff around the upper arm. Inflate the cuff to a pressure exceeding the systolic blood pressure. Then, exhaust the air from the cuff gradually. While the pressure is detected in the cuff in the air exhaustion stage, the pulse waveform appears in synchronization with the heart rate.

The pulse waveform suddenly increases near the systolic blood pressure. It increases further with exhaustion until it reaches the highest in amplitude, then decreases gradually. The changes in the pulse waveform are illustrated to the right.

The oscillometric blood pressure measurement evaluates the point where the amplitude increases suddenly after the pulse in the cuff pressure is detected, as the systolic blood pressure, the point where the amplitude reaches the highest, as the mean blood pressure, and the point where the amplitude decreases gradually and becomes small, as the diastolic blood pressure.

Actually, the pressure sensor detects the subtle changes in the cuff pressure with time, stores the pulse waveform in memory, and evaluates the systolic and diastolic blood pressures according to the oscillometric measurement algorithm.

The details in the algorithm vary with the blood pressure monitor. Blood pressure values of adults and infants, measured by the oscillometric method, compare with those measured by the auscultatory method. Diastolic blood pressure is defined to be the end point of phase 4 in the auscultatory method.

The pulse waveform of the cuff pressure depends on the characteristics of the cuff material. Therefore, using the specified cuff, the measurement accuracy is maintained according to the measurement algorithm.

The length of the hose is to be within 3.5 m, in consideration of the damping characteristics due to pulse wave propagation.

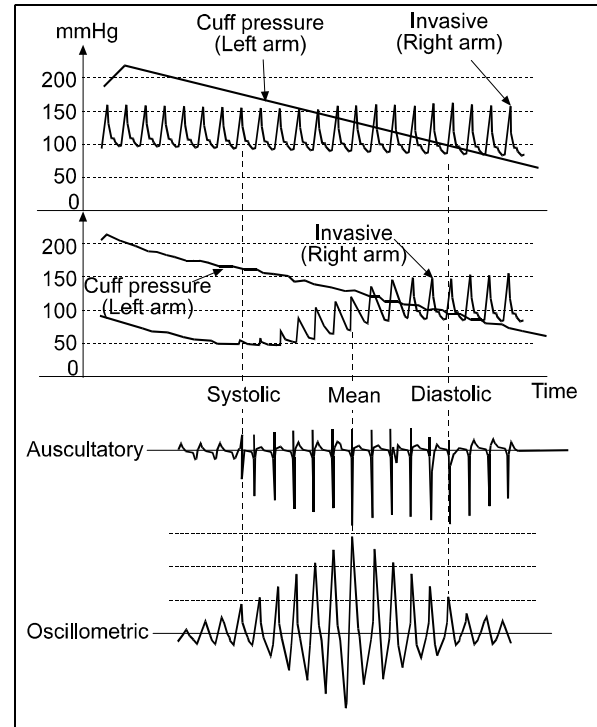

## Causes of errors

The pulse during blood pressure measurement is indicated in a graph, which can be an objective indicator of the reliability in the measurement accuracy. When noises occur due to irregular heart rhythm or physical movements, the amplitude changes abnormally in the graph. When it happens, blood pressure should be measured again, or be checked using other methods. The following are the main causes of errors in blood pressure measurement.

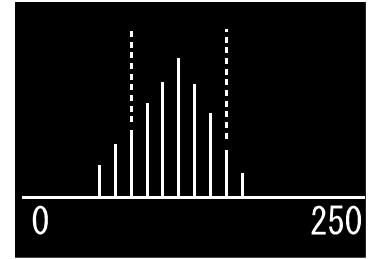

Pulse graph

### Cuff position

The cuff should be at the same level as the heart. Otherwise, a measurement error occurs. For example, if the cuff is 10 cm lower than the heart level, the blood pressure measures 7 mmHg higher.

### Cuff size

The cuff size should be adequate. Otherwise, a measurement error occurs. The small cuff yields high blood pressure, regardless of the proper cuff pressure or normal artery. The large cuff yields low blood pressure, especially for those who suffer from severe arteriosclerosis or have abnormal arterial valve. The wrong cuff size is the main reason of the big difference that occurs between the results taken by invasive blood pressure measurement and by oscillometric blood pressure measurement.

The cuff has the area labeled RANGE on it. When attached, the cuff inner end should be within the area labeled RANGE. Using the indicator, select the proper cuff for the patient.

The accuracy of the blood pressure monitor is guaranteed using the pressure accuracy of the pressure sensor, exhaust characteristics and measurement algorithm, as long as the proper cuff and hose are used.

Check the pressure accuracy of the pressure sensor and exhaust characteristics periodically as specified in "7-2 Calibration".

## A-2 SpO<sub>2</sub>

### Measuring principle

Oxygen, bound to hemoglobin, is carried by blood. Hemoglobin that is bound to oxygen is called oxygenated hemoglobin (HbO<sub>2</sub>), and that is not bound to oxygen is called reduced hemoglobin (Hb). Arterial oxygen saturation is the percentage of oxygenated hemoglobin in the blood.

$$\text{Arterial oxygen saturation} = \text{HbO}_2 / (\text{Hb} + \text{HbO}_2)$$

Oxygen-rich arterial blood is red while venous blood after the oxygen has been removed is dark. The difference in color comes from the difference in light-absorbing properties of oxygenated hemoglobin and reduced hemoglobin. (Refer to Figure A-1.)

A pulse oximeter uses the difference in light-absorbing properties of hemoglobin to obtain arterial oxygen saturation.

When the optical density of the body surface is obtained optically, it is the characteristic of the body part that includes tissue, venous blood and arterial blood. (Refer to Figure A-2.) The area that the optical density is pulsating due to the heart pumping function is called the photoelectric pulse and reflects the arterial blood properties. When measuring the photoelectric pulse using two wavelengths, the ratio in amplitudes is obtained temporarily as the arterial oxygen saturation.

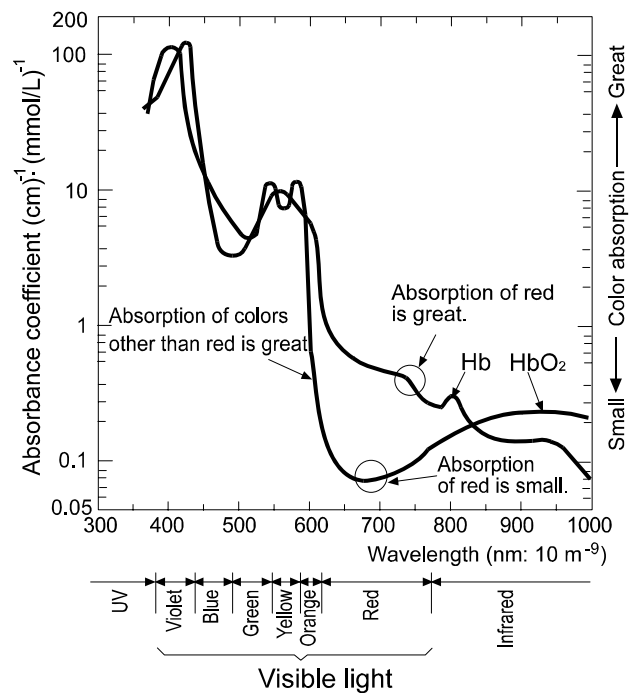

Figure A-1

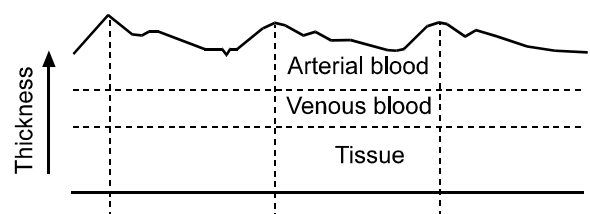
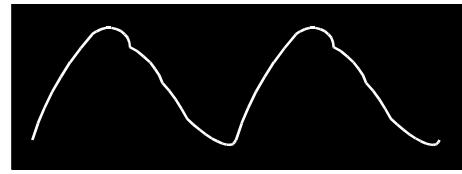

Figure A-2

## Causes of errors

In the pulse oximeter, adequate waveform implies the reliability. Always check the plethysmograph or bar graph for noises and disturbances. When noises or disturbances occur, check the probe connection or patient condition. The following are the main causes of errors in arterial oxygen saturation measurement.



Plethysmograph

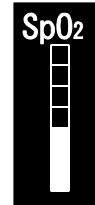

Pulse bar graph

### Abnormal hemoglobin

Besides oxygenated hemoglobin and reduced hemoglobin, there are carboxyhemoglobin (COHb) and methemoglobin (MetHb). They do not carry oxygen and are called abnormal hemoglobin. Normally, carboxyhemoglobin is about 1%. Methemoglobin is abundant in neonates, but it decreases to a negligible level as they grow. When abnormal hemoglobin has increased due to carbon dioxide poisoning or methemoglobinemia, a measurement error occurs. For those suffering from these conditions, 2-wavelength pulse oximeter can not be used.

### Venous pulsations

When the sensor is secured tightly with tape, the venous pulsations may be also detected and the lower arterial oxygen saturation is obtained.

### Low perfusion

When peripheral circulation disorder exists, pulses enough to detect the arterial oxygen saturation can not be obtained. Do not secure the sensor too tightly with tape or do not place the probe at the same location for a long period of time.

A pulse oximeter does not require calibration. Check the performance using the optional checker periodically.

# Appendix B: External Dimensions

TM-2560G / TM-2564G

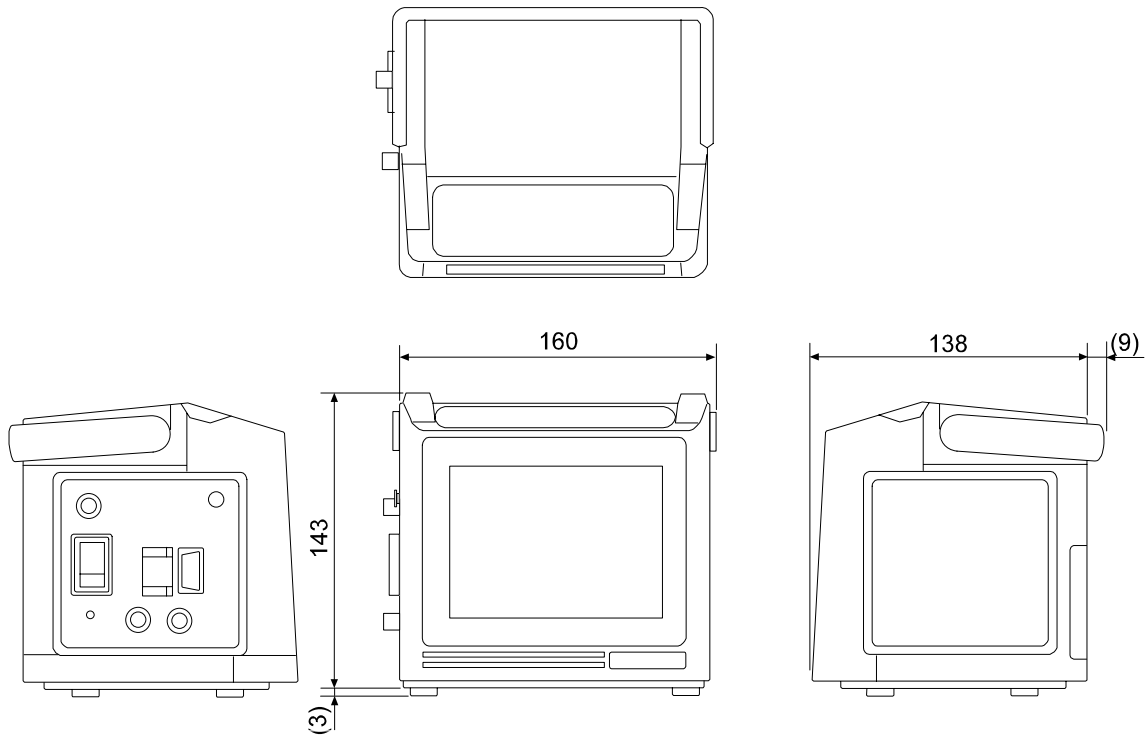

TM-2560GP / TM-2564GP

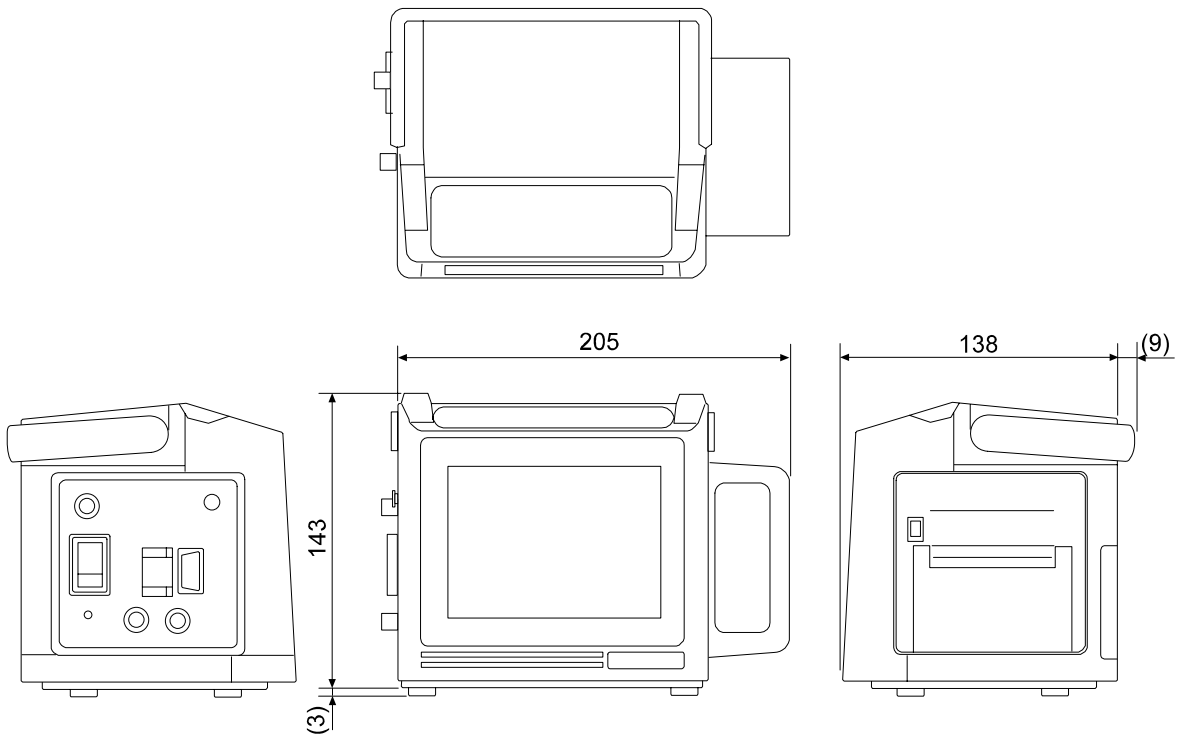

Unit: mm