

AD-4403-FP

**Explosion Protected Weighing
Indicator**

ST Series

**Weighing Indicator for Explosion
Protected Platform Scale**

INSTRUCTION MANUAL

Read all information in this manual and the ST series manual for the platform carefully and be fully knowledgeable about the unit before use. And after you read, keep this manual at hand so that you can refer to it whenever necessary.

© 2000 A&D Company Ltd. All rights reserved.

No part of this publication may be reproduced, transmitted, transcribed, or translated into any language in any form by any means without the written permission of A&D Company Ltd.

The contents of this manual and the specifications of the instrument covered by this manual are subject to change for improvement without notice.

CONTENTS

APPENDIX	II
SAFETY TERMS USED IN THIS MANUAL.....	III
WARNING LABEL	IV
SAFETY PRECAUTIONS FOR INSTALLATION	V
SAFETY PRECAUTIONS DURING OPERATION	V
ABOUT THIS MANUAL	V
1. INTRODUCTION	1-1
1-1 FEATURES	1-1
1-2 FRONT PANEL	1-2
1-3 DISPLAY	1-3
1-4 OPERATION KEYS.....	1-4
1-5 INSIDE THE CASE	1-8
2. INSTALLATION	2-1
2-1 PRECAUTIONS	2-1
2-2 WIRING.....	2-2
2-3 INSTALLING CONDUIT FITTINGS OPTION OP-10 - 14	2-5
2-4 INSTALLING WALL-MOUNTING FITTINGS	2-6
3. OPERATION.....	3-1
3-1 TURNING THE POWER ON	3-1
3-2 BASIC OPERATION.....	3-1
3-3 SETTING AND RECALLING SET POINTS.....	3-2
3-4 RECALLING THROUGH CLEARING ACCUMULATION DATA.....	3-3
3-5 EDITING ACCUMULATION DATA.....	3-4
4. CALIBRATION	4-1
4-1 GENERAL	4-1
4-2 DIGITAL SPAN CALIBRATION.....	4-1
4-3 ACTUAL LOAD CALIBRATION.....	4-1
4-4 GRAVITY COMPENSATION	4-3
5. FUNCTION SETTINGS	5-1
5-1 GENERAL	5-1
5-2 FUNCTION SETTINGS.....	5-2
6. WEIGHING	6-1
6-1 WEIGHING VALUE AND SET POINT	6-1
6-2 WEIGHING MODES.....	6-2
6-3 CALF-14="1" WEIGHING MODE	6-4
6-4 CALF-14="2" WEIGHING MODE	6-6
6-5 CALF-14="3" WEIGHING MODE (WITH NO SUPPLEMENTARY FLOW)	6-8
6-6 CALF-14="3" WEIGHING MODE (WITH SUPPLEMENTARY FLOW)	6-10
6-7 CALF-14="4" WEIGHING MODE	6-12
6-8 CALF-14="5" WEIGHING MODE	6-14
6-9 CALF-14=6 WEIGHING MODE.....	6-16
6-10 CALF-14=7 WEIGHING MODE.....	6-17
6-11 CALF-14=8 WEIGHING MODE.....	6-18
6-12 CALF-14=9 WEIGHING MODE.....	6-19

7. OTHER FUNCTIONS	7-1
7-1 AUTO PRINT.....	7-1
7-2 AUTOMATIC ACCUMULATION	7-1
7-3 AUTOMATIC FREE FALL COMPENSATION	7-2
8. INTERFACE	8-1
8-1 CONTROL INPUT / OUTPUT	8-1
8-2 STANDARD SERIAL OUTPUT	8-3
8-3 OPTION (OP-03: RS-422/485, OP-04: RS-232C).....	8-4
8-4 OPTION (OP-07 ANALOG OUTPUT)	8-7
8-5 DATA TRANSMITTING MODE	8-8
8-6 DATA TRANSMITTING FORMAT	8-9
8-7 COMMAND MODE.....	8-13
9. MAINTENANCE	9-1
9-1 SYSTEM CHECK.....	9-1
9-2 CLEARING “ZERO” AND “TARE”	9-4
9-3 INITIALIZATION	9-5

APPENDIX

APPENDIX A: SPECIFICATIONS.....	A-1
SPECIFICATIONS	A-1
DIMENSIONS: INDICATOR.....	A-4
DIMENSIONS: OP-20 STAND	A-5
MOUNTING DIMENSIONS.....	A-6
APPENDIX B: ERROR CODES.....	B-1
LOAD CELL OUTPUT COMPENSATION.....	B-1
APPENDIX C: FUNCITON LIST	C-1
FNCF—BASIC FUNCTIONS	C-1
SQ F—WEIGHING SEQUENCE FUNCTIONS	C-4
IN F—CONTROL INPUT FUNCTIONS.....	C-7
OUTF—CONTROL OUTPUT FUNCTIONS	C-8
SIF—STANDARD SERIAL OUTPUT FUNCTIONS	C-9
RSF—OP-03:RS-422/485/ OP-04:RS-232C FUNCTIONS	C-10
ANF—ANALOG OUTPUT FUNCTIONS	C-11
CALF—CALIBRATION FUNCTIONS	C-12
APPENDIX D: GRAVITY ACCELERATION MAP	D-1
APPENDIX E: DATA OUTPUT EXAMPLES	E-1
OUTPUT CONDITIONS.....	E-1
FORM E	E-1
FORM F	E-2
FORM G.....	E-3
APPENDIX F: USER’S SETTING RECORD.....	F-1
FUNCTION SETTING RECORD	F-1
SET POINT SETTING RECORD	F-3

SAFETY TERMS USED IN THIS MANUAL



Symbol



This is the symbol used for precautions. Read carefully where  appears and follow the instructions to avoid injury or damage to your property.

Signal Words

Signal Words, “Danger”, “Warning”, and “Caution”, identify safety messages to the reader, and these words mean the followings;

Important information to alert you to a situation that might cause loss of life and serious injury.	 DANGER
Important information to alert you to a situation that might cause serious injury.	 WARNING
Important information to alert you to a situation that might cause injury.	 CAUTION

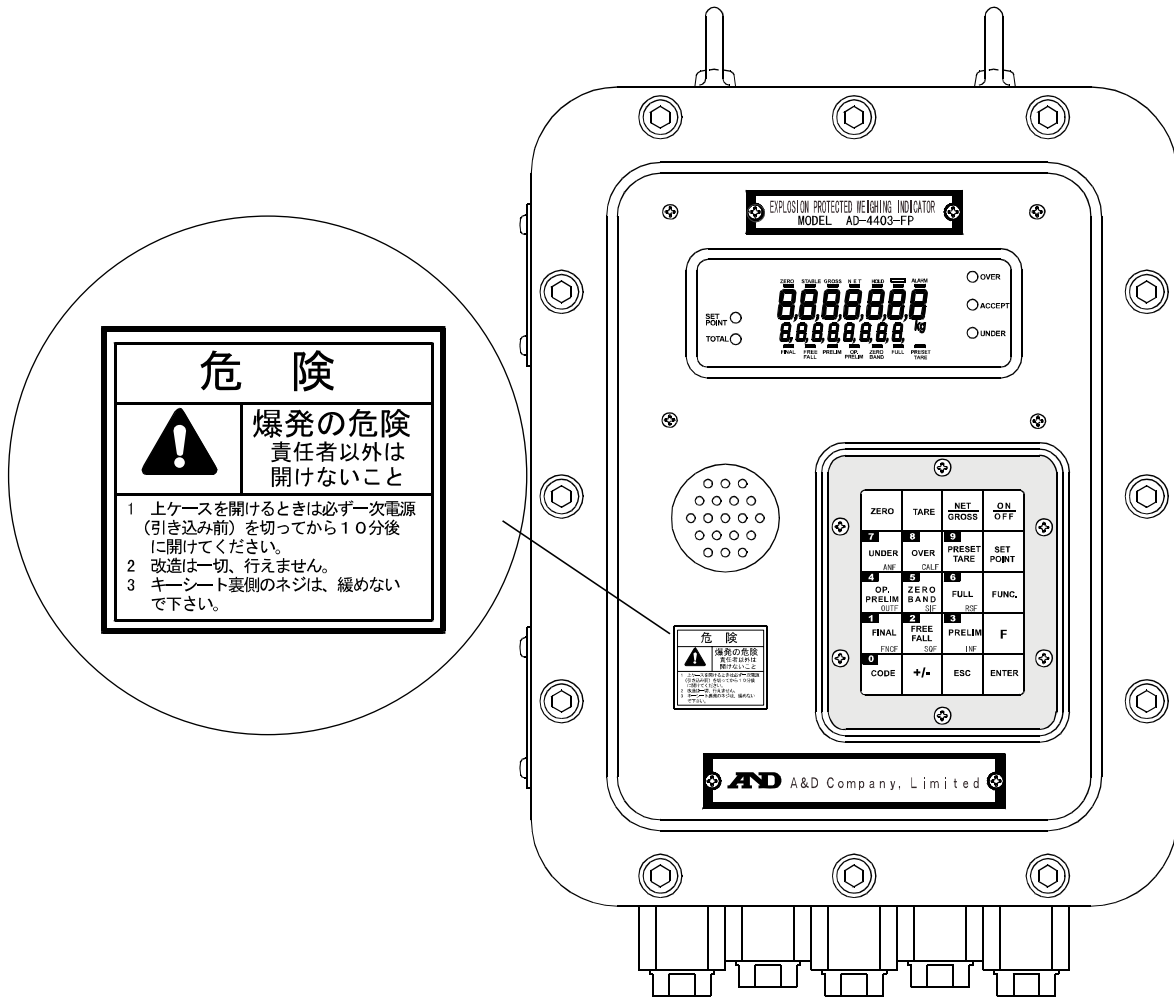

WARNING LABEL

A warning label is affixed to the product to call attention for the risk of explosion. Do not remove the label and keep it readable at all times.



* The picture above is of Type A model for weighing in the customer programmed control mode and the built-in automatic program mode.) with the Conduit fittings options.

SAFETY PRECAUTIONS FOR INSTALLATION

 DANGER	<p>The indicator complies with “ExdIIBT5X” specifications for Explosion protected devices. Install and use the indicator in a proper place to avoid explosion.</p> <p>Environments</p> <ul style="list-style-type: none"> • Install and operate the indicator in Zone 1 or Zone 2. Never use in Zone 0. • Do not install the unit in direct sunshine. • Avoid vibration, sudden temperature changes, wind, water, or excessive dirt. • Operate in environments with temperatures of between -5°C to 40°C and humidity of between 45% and 85% R.H. (non-condensing). • Mount the unit on a solid frame or wall. <p>Installation work</p> <ul style="list-style-type: none"> • Do engineering work and wiring in accordance with the requirements by laws and regulations related to hazardous area devices. • Only a trained professional with good knowledge of explosion protected devices should be allowed to perform the installation work. <p>Grounding</p> <ul style="list-style-type: none"> • To avoid electrical shock and accident from static electricity, plug the power cable into a properly wired earth grounded receptacle, or ground the “E” terminal of Power source terminals before connecting anything else to any of the instrument binding posts. • Do not share grounding with other units that create electrical noise. <p>Power supply</p> <ul style="list-style-type: none"> • The power source should be 100 VAC +10%/-15% specification; with a frequency of 50 or 60 Hz. Use a stable power source free from instantaneous dropout or noise. Sharing a power line could result in malfunctioning. • Do not turn the power on until all the installation work has been completed. <p>Before opening the front panel</p> <ul style="list-style-type: none"> • Turn the power off (primary power) and wait approximately ten minutes for the electrical charge to dissipate before opening the front panel.
 CAUTION	<p>The front panel door is thick and heavy. Be careful not to catch your finger in the door.</p>

SAFETY PRECAUTIONS DURING OPERATION

 DANGER	<p>Disassembly/ Modification Never try to disassemble or modify the unit. That may cause an explosion.</p> <p>When opening the Front panel. Cut off the main power supply and wait 10 minute before opening the front panel to avoid an explosion.</p>
---	--

ABOUT THIS MANUAL

This manual provides setup and operating instructions for the AD-4403-FP Explosion protected weighing indicator/ ST series indicator manufactured by A&D Company limited.

Read all information carefully and be fully knowledgeable about the unit before use. And after you read, keep this manual at hand so that you can refer to it whenever necessary.

The contents of this manual and the specifications are subject to change for improvement without notice.

1. INTRODUCTION

The AD-4403-FP/ ST is an Explosion protected weighing indicator to be installed and used in hazardous area: Zone 1 and Zone 2 where explosive gas exists in the air. It complies with the requirements from IEC (International Electrotechnical Commission) standard: Qualification number: C13526)

1-1 Features

- Complies with “ExdIIIBT5X” specifications for explosion protected devices (Qualification number: C13526)
- High speed sampling — 100 times per second.
- Five batch weighing modes and four check weighing modes.
- Two control modes;
 - Type A: Normal batching/ Loss-in-weigh/ Nozzle controlled weighing mode
 - Type B: Check weighing mode.
- Six input and six output terminals for the Control I/O.
- Up to 100 sets of set points are available. Each set is assigned a code number.
- Serial Interface and an buzzer are built in.
- Lithium battery backs up the data of zero compensation, tare weight, set point, and accumulation data (weight and count).
- Non volatile memory stores the calibration and function setting data.
- Four 350-Ω load cells can be driven.

1-2 Front Panel

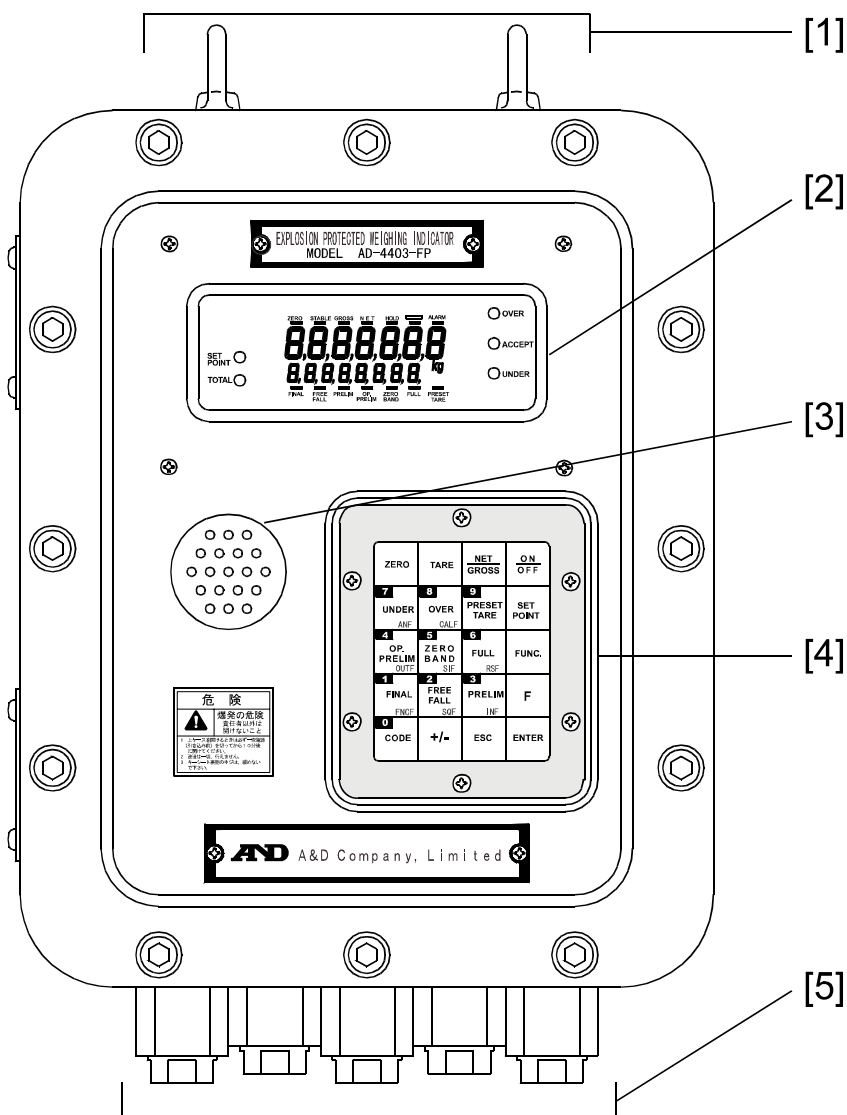

The picture above is of Type A model for normal batching/ loss-in-weigh/ nozzle controlled weighing mode) with the conduit fitting option.

#	Name	Description
[1]	Hooks	Used for lifting.
[2]	Display	Displays weight, status, and messages. See {1-3 Display}
[3]	Buzzer	Sounds for a warning or when weighing completes. (selective)
[4]	Operation Keys	Tare, Zero, and set / call / recall Set point and do settings. Two kinds of Overlay: Type A and Type B. See {1-4 Operation Keys }
[5]	Conduit fittings	Explosion-proof type fittings for wiring cables. 5 conduit fittings available. 2 fittings (fitting cable diameter: beyond 10 mm, up to 12 mm) are already with the unit. 3 more fittings can be added. (OP-10 to 14).

1-3 Display

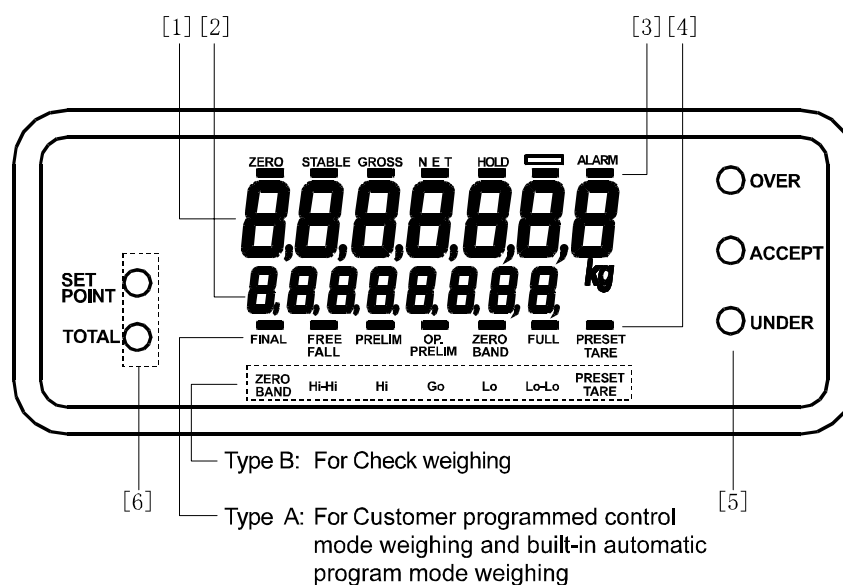

#	Name	Description	
[1]	Main Display	A 7-digit 7-segment display. Displays gross weight, net weight, etc	
[2]	Sub display	An 8-digit 7-segment display. The display content can be selected at function settings. See {Appendix C: Function List }	
[3]	Status display section (upper)	“—”	The upper “—” mark indicates the status of the weight.
		[ZERO]	Illuminates at the center-zero.
		[STABLE]	<ul style="list-style-type: none"> Illuminates at a stable reading. The stable condition can be changed at the function setting of CALF-09. See, {Appendix C: Function List }
		[GROSS]	Illuminates with the gross weight displayed.
		[NET]	Illuminates with the net weight displayed.
		[HOLD]	Illuminates when the weight display is being held. Either normal-hold or peak-hold can be selected at function settings, FncF-08. See {Appendix C: Function List }
			This display capability can be selected for an application. Select at the function settings of FncF-05. See {Appendix C: Function List }
		[ALARM]	Illuminates when zero range error, weighing capacity overflow, low battery, or accumulation data over have happened.
[4]	Status display section (lower)	<ul style="list-style-type: none"> Illuminates when a set point output is turned on in the normal mode. Indicates a type of set point in the set point setting mode. 	
[5]	Right LEDs	<ul style="list-style-type: none"> Indicates a result of weighing. Indicates content of the sub display In the set point setting mode. 	
[6]	Left LEDs	<ul style="list-style-type: none"> Indicates content of the sub display. Blinks when it is ready to change or erase the settings. 	

1-4 Operation Keys

Type A for the normal batching/ loss-in-weigh/ nozzle controlled weighing mode.

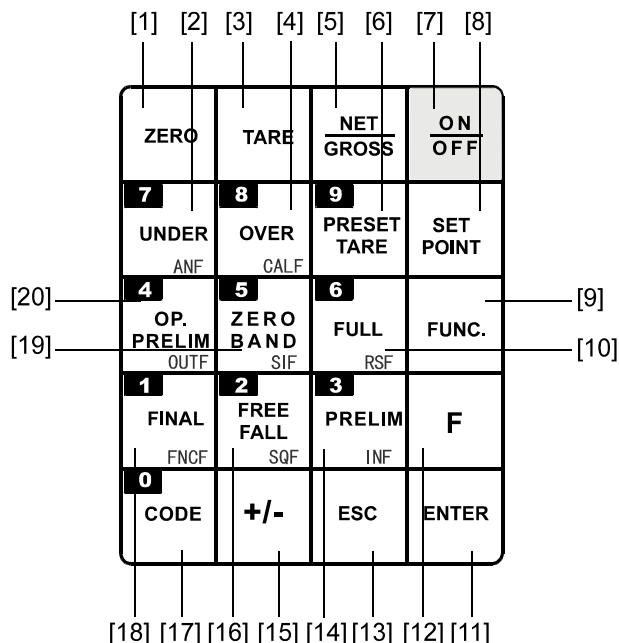

#	Name	Description
[1]	[ZERO]	Returns the display to the center of zero. The range of zero can be set at CALF-05. See { Appendix C: Function List}
[2]	[7]	Works as a numerical key, 7, used for settings.
	[UNDER] [ANF]	Selects the “under limit” weight. Enters the setting mode for the analog output (OP-07). See {8-4 Option-07:Analog Output}
[3]	[TARE]	Subtracts the tare. When gross weight is “0”, it clears tare. The tare subtraction condition can be set with CALF-10 and 11. See {Appendix C: Function List}
[4]	[8]	Works as a numerical key, 8, used for settings.
	[OVER] [CALF]	Selects the “over limit” weight. Enters the calibration mode. See {4. Calibration}
[5]	[GROSS/NET]	Switches the display between “gross” and “net” weight.
[6]	[9]	Works as a numerical key, 9, used for settings.
	[PRESET TARE]	Selects the “preset tare” weight.
[7]	[ON/OFF]	<ul style="list-style-type: none"> Turns ON and OFF the display in the normal mode. In the OFF mode, display and external I/Os are all off with the “O” mark on the display. Available during operation. (Press the key more than 0.3 seconds to activate.)
[8]	[SET POINT]	Selects a set point of the code input by numerical keys.
[9]	[FUNC.]	Enters the function setting mode. See {5-2. Function Settings}. (Press the key more than 0.3 seconds to activate.)
[10]	[6]	Works as a numerical key, 6, used for settings.
	[FULL]	Selects the “full” weight.
	[RSF]	Enters the setting mode for the OP-03: RS-422/485, OP-04: RS-232C. See {8-3 OP-03:RS-422/485, OP-04:RS-232C}

#	Name	Description
[11]	[ENTER]	Writes a value into memory or ends the setting.
[12]	[F]	Selects item. See FncF-02 {Appendix C: Function List}.
[13]	[ESC]	<ul style="list-style-type: none"> • Returns to the previous status. • Escapes from the current operation. • Mutes the sound of the buzzer.
[14]	[3]	Works as a numerical key, 3, used for settings.
	[PRELIM]	Selects the “preliminary” weight.
	[INF]	Enters the setting mode for the control input. See {Appendix C: Function List}.
[15]	[+/-]	<ul style="list-style-type: none"> • Sets a polarity + (blank) or -. • Returns the setting to the previous. • Sets a blank in the data.
[16]	[2]	Works as a numerical key, 2, used for settings.
	[FREE FALL]	Selects the “free fall” weight.
	[SQF]	Enters the weighing sequence function mode. See {Appendix C: Function List}.
[17]	[0]	Works as a numerical key, 0, used for settings.
	[CODE]	<ul style="list-style-type: none"> • Selects a code number. • Calls a set point of the code input by numerical keys. • Edits (call/ retrieve/copy/erase) a set point by code. • Selects set points of the code. • Sets and changes set points of the code input by numerical keys.
[18]	[1]	Works as a numerical key, 1, used for settings.
	[FINAL]	Selects “final” weight.
	[FNCF]	Enters the basic function mode. See {Appendix C: Function List}.
[19]	[5]	Works as a numerical key, 5, used for settings.
	[ZERO BAND]	Selects the “zero band” weight.
	[SIF]	Enters the standard Serial Output mode. See {Appendix C: Function List}.
[20]	[4]	Works as a numerical key, 4, used for settings.
	[OP. PRELIM]	Selects the “optional preliminary” weight.
	[OUTF]	Enters the weighing sequence function mode. See {Appendix C: Function List}.

Type B for the check-weighing mode.

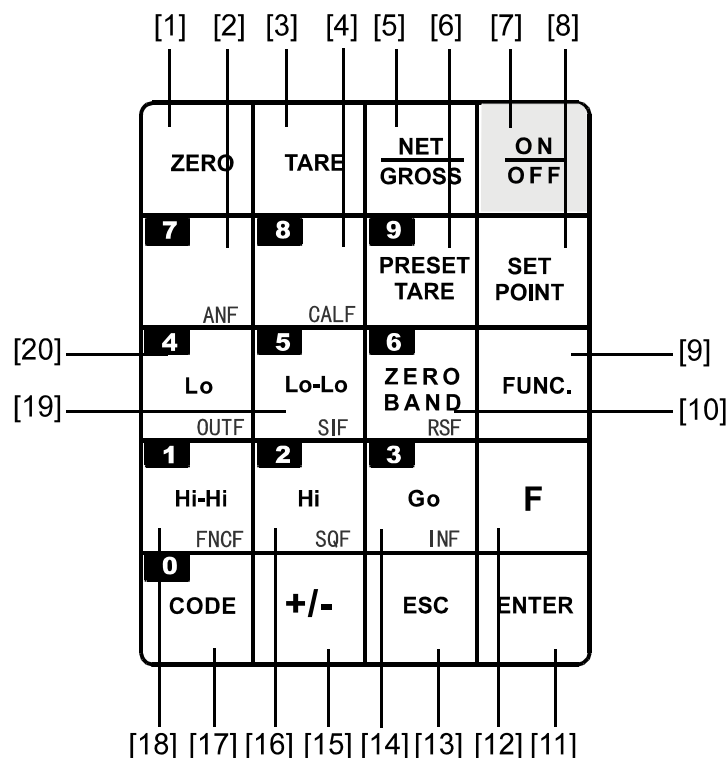

#	Name	Description
[1]	[ZERO]	Returns the display to the center of zero. The range of zero can be set at CALF-05. See { Appendix C: Function List}
[2]	[7]	Works as a numerical key, 7, used for settings.
	[ANF]	Enters the analog output (OP-07) mode. See {8-4 Option-07:Analog Output}
[3]	[TARE]	Subtracts the tare. When gross weight is "0", it clears tare. The tare subtraction condition can be set with CALF-10 and 11. See {Appendix C: Function List}
[4]	[8]	Works as a numerical key, 8, used for settings.
	[CALF]	Enters the calibration mode. See {4. Calibration}
[5]	[GROSS/NET]	Switches the display between "gross" and "net" weight.
[6]	[9]	Works as a numerical key, 9, used for settings.
	[PRESET TARE]	Selects the "preset tare" weight.
[7]	[ON/OFF]	<ul style="list-style-type: none"> • Turns ON and OFF the display in the normal mode. • In the OFF mode, display and external I/Os are all off with the "O" mark on the display. • Available during operation. (Press the key more than 0.3 seconds to activate.)
[8]	[SET POINT]	Selects a set point of the code input by numerical keys.
[9]	[FUNC.]	Enters the function setting mode. See {5-2. Function Settings}. (Press the key more than 0.3 seconds to activate.)
[10]	[6]	Works as a numerical key, 6, used for settings.
	[ZERO BAND]	Selects the "zero band" weight.
	[RSF]	Enters the setting mode for the OP-03: RS-422/485, OP-04: RS-232C. See {8-3 OP-03:RS-422/485, OP-04:RS-232C}

#	Name	Description
[11]	[ENTER]	Writes a value into memory or ends the setting.
[12]	[F]	Selects an item. See FncF-02 {Appendix C: Function List}.
[13]	[ESC]	<ul style="list-style-type: none"> • Returns to the previous status. • Escapes from the current operation. • Mutes the sound of the buzzer.
[14]	[3]	Works as a numerical key, 3, used for settings.
	[Go]	Selects the “Go” weight in the check weighing mode.
	[INF]	Enters the setting mode for the control input. See {Appendix C: Function List}.
[15]	[+/-]	<p>Sets a polarity + (blank) or -.</p> <p>Returns the setting to the previous.</p> <p>Sets a blank in the data.</p>
[16]	[2]	Works as a numerical key, 2, used for settings.
	[Hi]	Selects the “Hi limit” weight in the check-weighing mode.
	[SQF]	Enters the weighing sequence function mode. See {Appendix C: Function List}.
[17]	[0]	Works as a numerical key, 0, used for settings.
	[CODE]	<ul style="list-style-type: none"> • Selects a code number. • Calls a set point of the code input by numerical keys. • Edits (call/ retrieve/copy/erase) a set point by code. • Selects set points of the code. • Sets and changes a set point of the code input by numerical keys.
[18]	[1]	Works as a numerical key, 1, used for settings.
	[Hi-Hi]	Selects the “Hi-Hi” weight in the check-weighing mode.
	[FNCF]	Enters the basic function mode. See {Appendix C: Function List}.
[19]	[5]	Works as a numerical key, 5, used for settings.
	[Lo-Lo]	Selects the “Lo-Lo limit” weight in the check-weighing mode.
	[SIF]	Enters the standard Serial Output mode. See {Appendix C: Function List}.
[20]	[4]	Works as a numerical key, 4, used for settings.
	[Lo]	Selects the “Lo limit ” weight in the check-weighing mode.
	[OUTF]	Enters the weighing sequence function mode. See {Appendix C: Function List}.

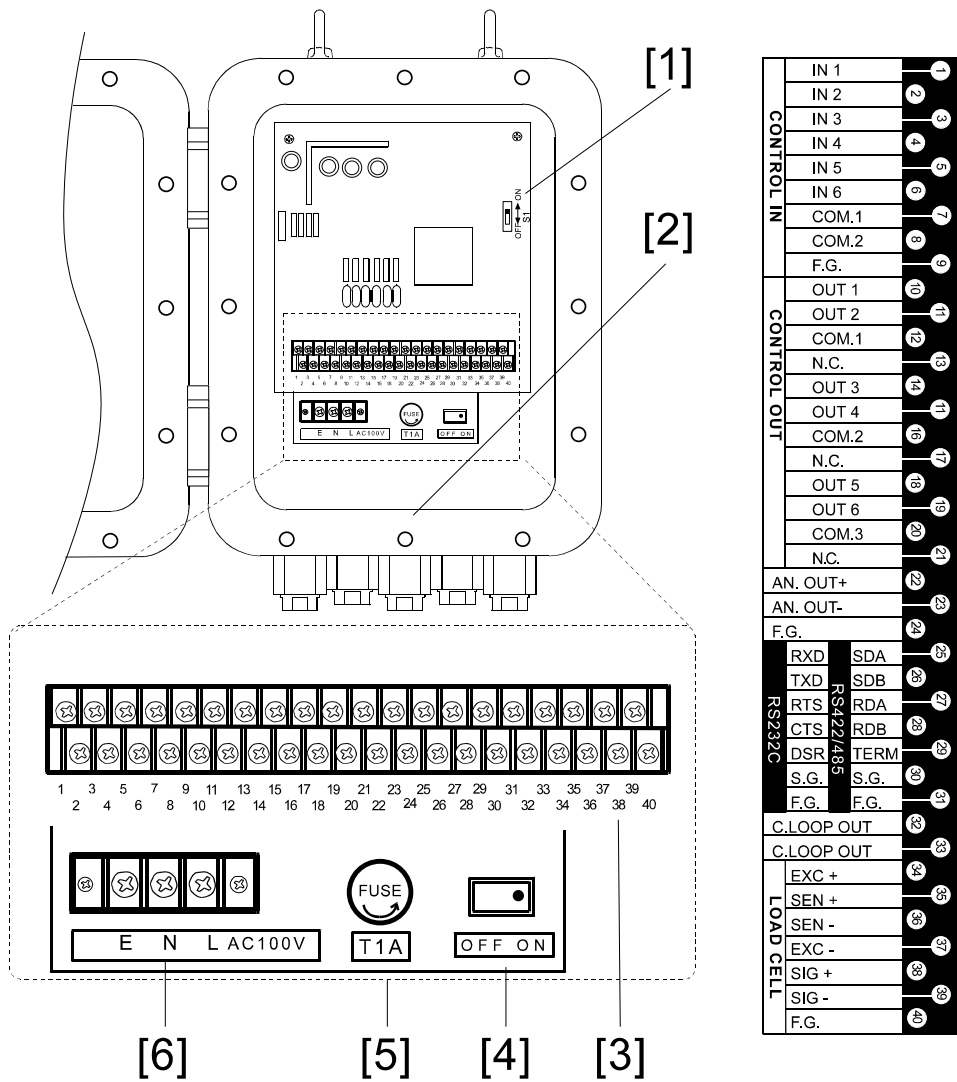

1-5 Inside the Case



#	Name	Description
[1]	Calibration disable switch	Disables the calibration function. ON Calibration enabled OFF Calibration disabled
[2]	Wiring label	Shows cable connections.
[3]	Control signal terminals	For control signal cables.
[4]	Power switch	Turns on and off the power to the unit. Keep the switch on during use. Use the main power switch outside to turn the power off.
[5]	Fuse holder	Stores a 1A time-lag fuse
[6]	Power line terminals	For the power line (100 VAC)

2. INSTALLATION

2-1 Precautions

<p> DANGER</p>	<p>The indicator complies with “ExdII BT5X” specifications for Explosion protected devices. Install and use the indicator in a proper place to avoid explosion.</p> <p>Environments</p> <ul style="list-style-type: none"> • Install and operate the indicator in Zone 1 or Zone 2. Never use in Zone 0. • Do not install the unit in direct sunshine. • Avoid vibration, sudden temperature changes, wind, water, or excessive dirt. • Operate in environments with temperatures of between -5°C to 40°C and humidity of between 45% and 85% R.H. (non-condensing). • Mount the unit on a solid frame or wall. <p>Installation work</p> <ul style="list-style-type: none"> • Do engineering work and wiring in accordance with the requirements by laws and regulations related to hazardous area devices. • Only a trained professional with good knowledge of Explosion protected devices should be allowed to perform the installation work. <p>Grounding</p> <ul style="list-style-type: none"> • To avoid electrical shock and accident from static electricity, plug the power cable into a properly wired earth grounded receptacle, or ground the “E” terminal of Power terminals before connecting anything else to any of the instrument binding posts. • Do not share grounding with other units that create electrical noise. <p>Power supply</p> <ul style="list-style-type: none"> • The power source should be 100 VAC +10%/-15% specification; with a frequency of 50 or 60 Hz. Use a stable power source free from instantaneous dropout or noise. Sharing a power line could result in malfunctioning. • Do not turn the power on until all the installation work has been completed. <p>Before opening the front panel</p> <ul style="list-style-type: none"> • Turn the power off (primary power) and wait approximately ten minutes for the electrical charge to dissipate before opening the front panel.
<p> CAUTION</p>	<p>The front panel door is thick and heavy. Be careful not to catch your finger in the door.</p>

2-2 Wiring

Open the front panel door removing screws on the front panel, and connect a power cable, load cell cables, and control signal cables to the terminals inside the case. Follow the instructions below.

Cable used

Load cell	The use of a 6 wire shielded cable is recommended in order to reduce weighing error. (When using a 4-wire cable, connect pin # 34 to # 35, and pin # 36 to # 37.) If the system requires two or more load cells, use an explosion-protected type of summing box to input the signal into the indicator.
Control signal cable	Use a shielded cable and connect its shield to pin # 40 (Frame ground).

Power cable

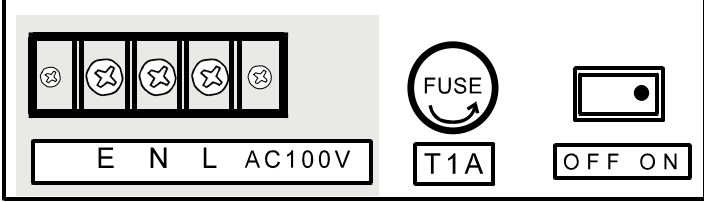
	
Terminal	Description
E	Ground
N	AC power supply
L	

Load cell cable

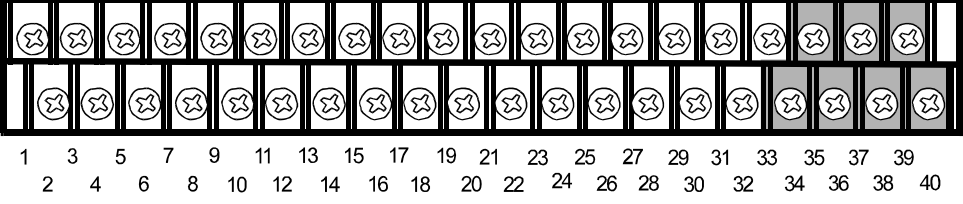
			
Terminal	Description		Cable color (ST Series only)
34	EXC+	Excitation +	Red
35	SEN+	Sense +	Orange
36	SEN-	Sense -	Black
37	EXC-	Excitation -	White
38	SIG+	Signal +	Green
39	SIG-	Signal -	Blue
40	F.G.	Frame ground	Yellow

Control signal cable

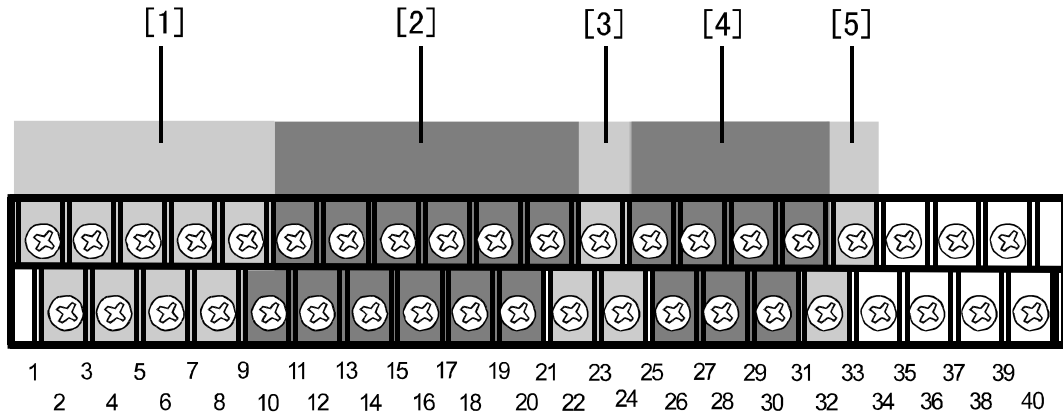

#	Name	Pin #	Name	Description		
[1]	Control Input	1	IN 1	Control input function—INF-01		
		2	IN 2	Control input function—INF-02		
		3	IN 3	Control input function—INF-03		
		4	IN 4	Control input function—INF-04		
		5	IN 5	Control input function—INF-05		
		6	IN 6	Control input function—INF-06		
		7	COM. 1	Common. Connected inside.		
		8	COM. 2			
		9	F.G.	Frame ground		
[2]	Control output	10	OUT 1	Control output function—OUTF-01		
		11	OUT 2	Control output function—OUTF-02		
		12	COM. 1	Common for output 1 and 2		
		13	N.C.	No connection		
		14	OUT 3	Control output function—OUTF-03		
		15	OUT 4	Control output function—OUTF-04		
		16	COM. 2	Common for output 3 and 4		
		17	N.C.	No connection		
		18	OUT 5	Control output function—OUTF-05		
		19	OUT 6	Control output function—OUTF-06		
		20	COM. 3	Common for Output 5 and 6		
[3]	OP-07 (Analog output)	22	AN. OUT+	Analog Output (OP-07) High		
		23	AN. OUT-	Analog Output (OP-07) Low		
		24	F.G.	Frame ground		
[4]	OP-03 (RS-422/485) OP-04 (RS-232C)	25	OP-03 (RS-422/485)	SDA	OP-04 (RS-232C)	RXD
		26		SDB		TXD
		27		RDA		RTS
		28		RDB		CTS
		29		TERM		DSR
		30		S.G. (Signal ground)		S.G. (Signal ground)
		31		F.G. (Frame ground)		F.G. (Frame ground)
[5]	Standard serial output	32	C. Loop Out	Standard Serial Output		
		33				

Before closing the door

Place the cable on the heat sink board to avoid pinching the cable when closing the door.

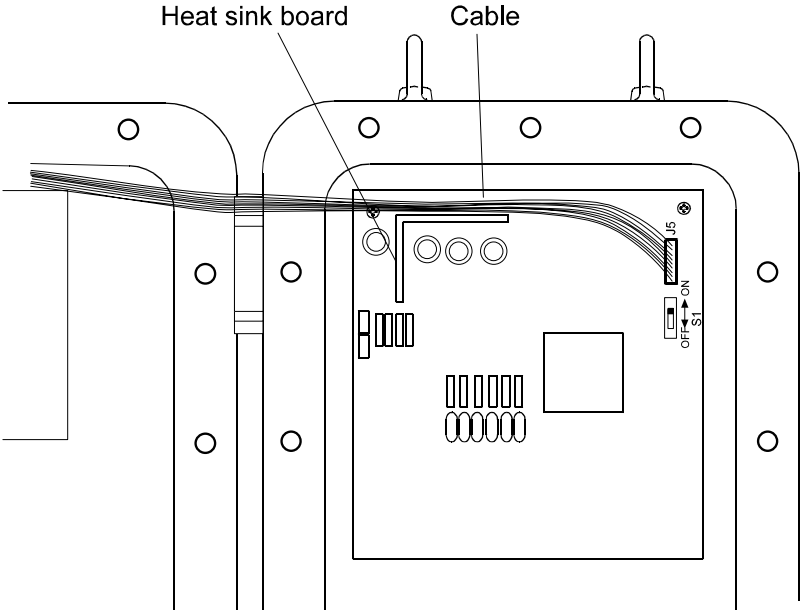

2-3 Installing Conduit Fittings Option OP-10 - 14

Affix conduit fittings to the unit following the instructions below.

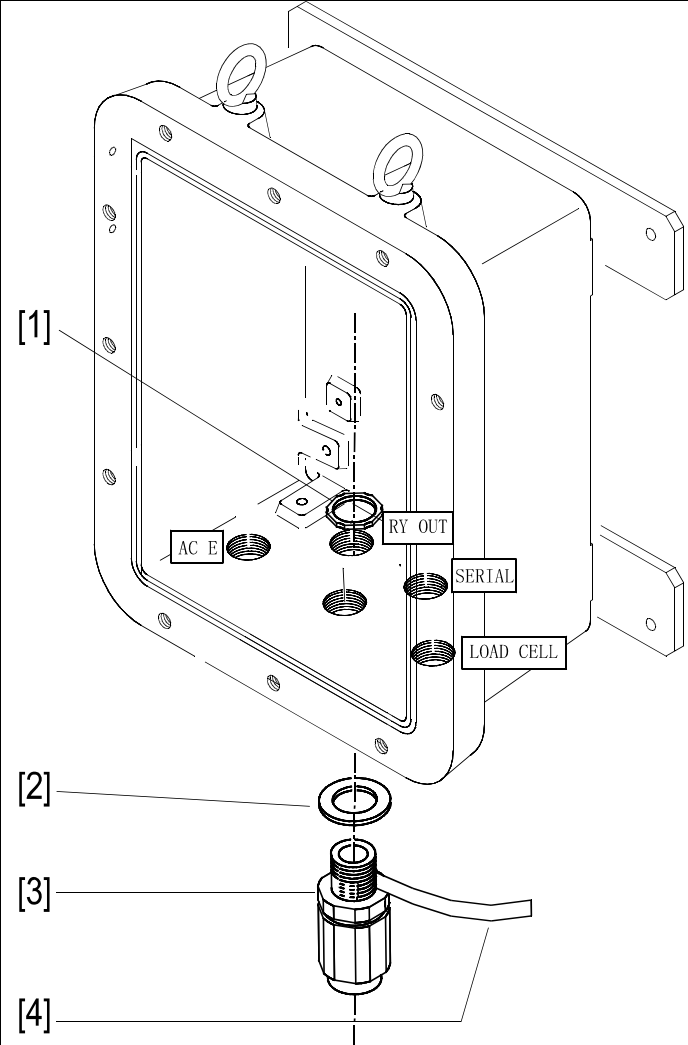

#	Parts Name
[1]	Lock nut
[2]	Gasket
[3]	Conduit fitting
[4]	Sealing tape

Procedures

- 1: Wind the [4] Sealing tape around the [3] Conduit fitting.
- 2: Insert into the SERIAL hole through the [2] Gasket.
- 3: Tighten it with the [1] Lock nut.

2-4 Installing Wall-Mounting Fittings

WARNING

The fittings have been attached temporarily when shipped. Before use, affix the wall-mounting fittings securely to the back of the unit with screws. Be sure to apply some threadlocker to the screws after fastening the screws to avoid loosened screws that may cause accidents.

Install the wall-mounting fittings following the instructions below.

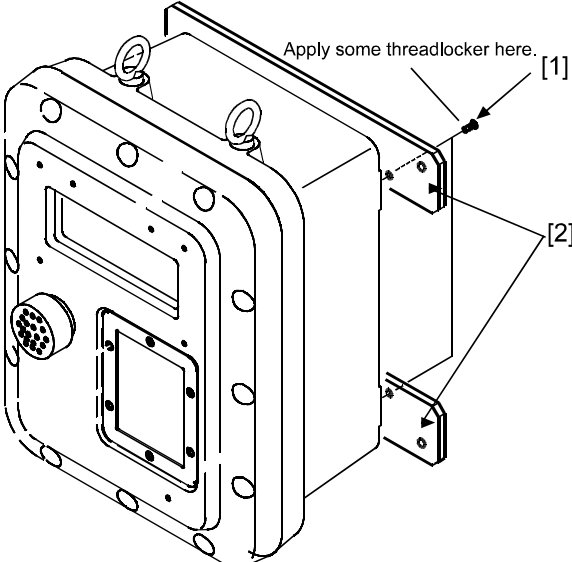
	#	Parts Name
	[1]	Four screws (M8)
	[2]	Wall-mounting fittings
Placing		
1: Tighten the [1] screws at a torque of 50 kgf.cm or more.		
2: Apply some threadlocker to the screws. (Threadlocker should be type 262 manufactured by the LOCTTITE company or an equivalent one with 90kgf.cm torque for a M8 screw)		

[Blank page]

3. OPERATION

3-1 Turning the Power On

- Turning on the power switch inside the case illuminates all the display for 2 seconds, then to normal display.
- [ON/OFF] turns the display on and off, not the power supply.
- When the power is turned OFF with “O” indicated (OFF mode), “O” will be displayed when turned ON next time. And when turned off with a weight display (Normal mode), it displays the weight.
- This manual explains the operation based on the normal mode.

3-2 Basic Operation

Action	Key Operation	
To set Zero.	[ZERO]	
To subtract Tare. When Gross weight is 0, clear the tare weight.	[TARE]	
To switch the display from “gross” to “net” weight and vice versa.	[GROSS/NET]	
To switch to the OFF mode from the normal mode.	[ON/OFF]	
To recall a set point.	[UNDER]	
	[OVER]	
	[PRESET TARE]	
	[OP. PRELIM] ([Lo])	* (Type B)
	[ZERO BAND] ([Lo-Lo])	
	[FULL] ([ZERO BAND])	
	[FINAL] ([Hi-Hi])	
	[FREE FALL] ([Hi])	
	[PRELIM] ([Go])	
[CODE]		

3-3 Setting and Recalling Set points

Setting set points

1. Enter the set point setting mode.	
<input type="checkbox"/>	Press [CODE] [<i>code number (2 digits)</i>] [SET POINT] [ENTER] in this order. It shows; Main display: "CodE XX" Sub display: "YYYYYY" Status display section (lower): "FINAL" mark turns on. Left LEDs: "SET POINT" LED blinks.
*	Use numerical keys ([0] – [9]) to type a code number.
*	Set a blank for the code number with [+/-] to change the set point in use.
*	Press [ESC] to return to the normal mode.
2. Select a set point.	
<input type="checkbox"/>	Select a set point with [F].
3. Input a set point.	
<input type="checkbox"/>	Input a set point with numerical keys ([0] – [9]) and set polarity with [+/-].
*	Preset tare weight can be set up to the capacity. If exceeds, "dAtA Err" appears on the sub display for 3 seconds. Try it again.
*	Press [ESC] to cancel the input. It returns to the previous value. (While the previous value is displayed, press [ESC] to return to the normal mode.)
*	[+/-] may not work with some set points.
4. Enter the set point into memory.	
<input type="checkbox"/>	Press [ENTER] to store the set point into memory.
*	Settings won't complete until [ENTER] is pressed.

Recalling set points

1. Input a code number to recall.	
<input type="checkbox"/>	Press [CODE] [<i>code number desired (2 digits)</i>] [ENTER] in this order.
*	Use numerical keys ([0] – [9]) to type a code number.
*	Press [ESC] to cancel the input and re-input. Or erase the digits typed with [+/-] and continue typing.
*	Code numbers without the final weight setting can't be recalled. In this case, "FinAL " and "not dAtA" are displayed for 3 seconds and returns to the normal mode.

3-4 Recalling through Clearing Accumulation data

1. Recall the accumulation data (weight and count).

- Press [CODE] [*code number (2 digits)*] [F] in this order. It shows;

Main display: "CodE **XX**" (Code number)

Sub display: "YYYYYY" (Accumulated weight)

Left LEDs: "TOTAL" LED turns on.

- * Use numerical keys ([0] – [9]) to type a code number.
- * Press [ESC] to cancel the input and re-input. Or erase the digits typed with [+/-] and continue typing.
- * Press [ESC] to return to the normal mode.

Recalling the accumulated count

- Press [FUNC.] to recall the accumulated count. (Pressing [FUNC.] displays the accumulated weight and the accumulated count alternately.) It shows;

Sub display: "nZZZZZZ" (Accumulated count)

Recalling the accumulation data in order of code number

- Press [F] to recall in order of code number. The accumulation data of the code is displayed. Press [F] to see the next.

Recalling the accumulation data designated by the code number

- Press [CODE] [*code number (2 digits)*] [ENTER] in this order. The accumulation data of the code is displayed.

2. Clear the accumulation data (if necessary).

- Press [+/-] to select the accumulation data to be cleared. It shows;

Sub display: "CLEAR"

Left LEDs: "TOTAL" LED blinks.

- Press [ENTER] to clear the data. it shows;

Sub display: "total"

Left LEDs: "TOTAL" LED blinks.

3. Escape from the accumulation data mode.

- Press [ESC] to return to the normal mode.

3-5 Editing Accumulation data

Set point editing modes

There are 8 modes for editing set point data.

Mode #	Mode name	Description
[0]	Mode 0	Retrieves the code number with no set point data setting.
[1]	Mode 1	Writes set point data over the set point designated by a code number.
[2]	Mode 2	Clears the set point and accumulation data designated by a code number.
[3]	Mode 3	Clears the accumulation data designated by a code number.
[4]	Mode 4	Displays all the set points that have been set.
[5]	Mode 5	Writes a tare weight over the preset tare weight designated by a code number.
[7]	Mode 7	Clear all the set point data settings.
[8]	Mode 8	Clear all the accumulation data.

Mode [6] and [9] are not in use.

General procedures

1. Enter the set point editing mode.	
<input type="checkbox"/>	Press [CODE] [FUNC.] in this order. It shows; <div style="margin-left: 40px;">Main display: "CodE"</div> <div style="margin-left: 40px;">Sub display: "oPErAtE"</div> <div style="margin-left: 40px;">Right LEDs: All the LEDs is on while in the mode.</div>
*	Press [ESC] to return to the normal mode.
2. Select the mode required.	
<input type="checkbox"/>	Select a mode # from the above list with numerical keys.
*	Press [ESC] to return to the normal mode.
3. Follow the procedures of each mode.	
<input type="checkbox"/>	Follow the procedures on the next page. See the following {Procedures for each mode}.
4. Escape from the set point editing mode.	
<input type="checkbox"/>	Press [ESC] to return to the normal mode.

Procedures for each mode

Mode #	Name	Description	Display
[0]	Mode 0	Retrieves the code number with no set point data set.	
		<input type="checkbox"/> Press [ENTER] to display the code number with no set point data. It returns to the set point editing mode after the action. * Press [ESC] to select another mode.	"CodE bL" "SEARCh " "SET POINT" LED: ON
[1]	Mode 1	Writes set point data over the set point designated by a code number.	
		<input type="checkbox"/> Input a 2-digit code number: "XX" to be copied, "YY" to be written over. * Type "0" ahead for a single digit code like "01". * Press [F] to choose the set point data now in use. "--" is displayed and that means "now in use". * Press [+/-] to cancel the input and re-input. * Press [ESC] to return to the set point editing mode. <input type="checkbox"/> Press [ENTER] to overwrite the data. It returns to the set point editing mode after the action. <input type="checkbox"/> If the data to be written over ("YY") has a preset set point, overwriting is not performed. "FaILCoPy" is shown for 2 seconds and the unit a wait to be re-input.	"CodE CP" "XX to YY" "SET POINT" LED: Blinking
[2]	Mode 2	Clears the set point and accumulation data designated by a code number.	
		<input type="checkbox"/> Input the 2-digit code number of the data to be cleared. * Press [+/-] to cancel the input and re-input. * Press [ESC] to return to the set point editing mode. <input type="checkbox"/> Press [ENTER] to clear the data. It returns to the set point editing mode after the action.	"CodE dt" "CLEAR " "SET POINT" LED: Blinking
[3]	Mode 3	Clears the accumulation data	
		<input type="checkbox"/> Input the 2-digit code number of the data to be cleared. * Press [+/-] to cancel the input and re-input. * Press [ESC] to return to the set point editing mode. <input type="checkbox"/> Press [ENTER] to clear the data. It returns to the set point editing mode after the action.	"CodE tL" "CLEAR " "TOTAL" LED: Blinking

Mode #	Name	Description	Display
[4]	Mode 4	Displays all the set points that have been set.	
		<input type="checkbox"/> Input the 2-digit code number of the data to be displayed. * Press [+/-] to cancel the input and re-input. * Press [ESC] to return to the set point editing mode. <input type="checkbox"/> Press [F] [ENTER] to display the set point data designated by the code number. <input type="checkbox"/> Press [F] to jump to a code with no set point data. * The type of set point is not changed. <input type="checkbox"/> Press [ENTER] several times to select a type of set point. Display shows; (Type A for normal batching/ loss-in-weigh/ nozzle controlled weighing mode) Final→ Free fall→ Preliminary→ Over limit→ Under limit→ Zero band→ Full→ Preset tare (Type B for the check-weighing mode.) Zero band→Hi-Hi→Hi→Go→Lo→Lo-Lo→ Preset tare <input type="checkbox"/> In case of "Preset tare", press [ENTER] to jump to a code with set point data. <input type="checkbox"/> After displaying all the data, the mode returns to the set point editing mode.	"Code " "ALL disp" "SET POINT" LED: Blinking
[5]	Mode 5	Writes a tare weight over the preset tare weight designated by a code number.	
		<input type="checkbox"/> Input the 2-digit code number of the preset tare weight data to be overwritten with the tare weight. * Press [+/-] to cancel the input and re-input. * Press [ESC] to return to the set point editing mode. <input type="checkbox"/> Press [ENTER] to overwrite the data. It returns to the set point editing mode after the action.	"Code " "tr CoPy" "SET POINT" LED: Blinking
[7]	Mode 7	Clears all the set point data that has been set.	
		<input type="checkbox"/> Press [ENTER] for more than 0.3 seconds to clear all the set point data that have been set. (Accumulation data, weight and counts, won't be cleared.) * Press [ESC] to return to the set point editing mode. * Perform Mode 7 and 8 to clear both set point data and accumulation data.	"Code dt" "ALL CLE" "SET POINT" LED: Blinking
[8]	Mode 8	Clears all the accumulation data that has been set.	
		<input type="checkbox"/> Press [ENTER] for more than 0.3 seconds to clear all accumulation data that has been set. * Press [ESC] to return to the set point editing mode. * Perform Mode 7 and 8 to clear both set point data and accumulation data.	"Code tL" "ALL CLE" "TOTAL" LED: Blinking

4. CALIBRATION

Section related:

{Appendix C:FUNCTION LIST: CALF—Calibration Functions}

{Appendix B:Erro codes}

4-1 General

There are three ways to calibrate zero and span.

Digital span calibration	Calibrates with load cell output voltage.
Actual load calibration	Calibrates with weights.
Gravity compensation	Sets the know acceleration rate (“g”) for your location

4-2 Digital Span Calibration

This is calibration using the load cell output voltage (mV/V) instead of weights. Function CAL-19 and CAL-20 configures the calibration function. See {Appendix C: FUNCTION LIST: CALF—Calibration Functions}.

1. Enter the zero voltage.
Enter the load cell output voltage at the zero point with numerical keys.
2. Enter the span voltage.
Enter the difference of the load cell output voltage between at the capacity and at the zero point.
3. Relate the span voltage with weight.
Relate the span voltage with displaying weight.

4-3 Actual load Calibration

Before actual load calibration

AD-4403-FP	ST Series
Weighing unit (CAL-01), decimal point position (CAL-02), and, capacity (CAL-03) should be set in prior to calibration. See {Appendix C: Function List}	<ul style="list-style-type: none"> • Perform “Gravity compensation” before the actual load calibration. (“g” must be set with or without the actual load calibration. • The scale has been calibrated at factory before shipment. However it must be re-calibrated at your location due to a change in gravity acceleration. • Turn the adjustable leveling feet until the level spirit shows that the platform is level before the actual load calibration.
<ul style="list-style-type: none"> • Connect the load cell cables before turning the power on. Calibration may not be done properly if connected after the power is turned on. • Set the calibration disable switch (inside the case) to the ON position to perform calibration. • In order to avoid influence by temperature drift, carry out this calibration 10 minutes or more after turning on the power. 	

Actual load calibration procedures

Calibration procedures vary by the type of calibration. Follow the step number in the table below to calibrate.

* When "**C ErrXX**" is displayed, there is something wrong with the calibration. See {Appendix B: Error Codes}.

Zero calibration only		
Span calibration only		
Zero and Span calibration		
1	1	<p style="text-align: center;">Get in the calibration mode.</p> <p><input type="checkbox"/> Press [CALF] while pressing [ENTER] in the normal mode, and press [ENTER] next. "CAL Set" is displayed. (ready to calibrate)</p> <p>* Press [ESC] to return to the normal mode.</p>
		<p style="text-align: center;">Calibrate Zero.</p> <p><input type="checkbox"/> Press [ENTER] to get into the zero calibration mode. Main display: "CAL 0" / Sub display: " "</p> <p>* To browse the gross weight, press [SET POINT], it will be displayed on the sub display. Press [SET POINT] to erase this display.</p> <p>* Press [ESC] to return to the normal mode.</p> <p><input type="checkbox"/> Press [ENTER] at a stable reading ("-" is on beneath "Stable") with no load. "-----" is displayed for 2 seconds and the displays show; Main display: "CAL SPn" / Sub display: "Capacity weight"</p> <p>* To end calibration without zero calibrated, press [ESC], "CAL End" is displayed.</p>
	2	<p style="text-align: center;">Move on to Span calibration.</p> <p><input type="checkbox"/> To skip zero calibration and perform span calibration only, press [ENTER]. When "CAL 0" is displayed, press [F].</p>
	3	<p style="text-align: center;">Calibrate Span.</p> <p><input type="checkbox"/> The displays show; Main display: "CAL SPn" / Sub display: "Capacity weight"</p> <p>* The capacity weight is of the value set in CALF-04.</p> <p>* To browse the gross weight, press [SET POINT], it will be displayed on the sub display. Press [SET POINT] to erase this display.</p> <p>* Press [ESC] to return to the normal mode.</p> <p>* To end calibration without span calibrated, press [ESC], "CAL End" is displayed.</p> <p><input type="checkbox"/> Input the weight of the calibration mass using the numerical keys of ([0] - [9]).</p> <p><input type="checkbox"/> Press [ENTER] at a stable reading ("-" is on beneath "Stable"). "-----" is displayed for 2 seconds and the displays show; Main display: "CAL End" / Sub display: " "</p>
3	4	<p style="text-align: center;">End Calibration after saving the calibration data in EEPROM.</p> <p><input type="checkbox"/> Press [ENTER] to save the calibration data in the EEPROM and return to the normal mode.</p> <p>* To return to the normal mode without saving the calibration data, press [ESC].</p>

4-4 Gravity compensation

1. Get in the calibration mode	
<input type="checkbox"/>	Press [CALF] while pressing [ENTER] in the normal mode, and press [ENTER] next. "CAL Set" is displayed. (ready to calibrate)
*	Press [ESC] to return to the normal mode.
2. Get in the Gravity compensation mode	
<input type="checkbox"/>	Press [FUNC.]. "GrAvity" is displayed on the main display and your "g" value is on the sub-display..
*	Press [ESC] to return to the normal mode.
3. Enter the know acceleration rate for your location	
<input type="checkbox"/>	Refer to {Appendix D: Gravity acceleration map} and enter the value on the map.
<input type="checkbox"/>	Press [ENTER] to save the calibration data.
*	Press [+/-] to cancel the input and re-input.
*	Press [ESC] to return to the normal mode.

5. FUNCTION SETTINGS

Section related: {Appendix C: Function list:}

The functions determine the operations of the indicator and each function is sorted into the groups by capabilities and represented by prefixing its group name.

- * All the function setting are done in the same manner except for FuncF-01.
- * All the setting information is stored in the EEPROM.

5-1 General

Function group	Display	Function Key
Basic functions	"FncF "	[FNCF]
Weighing sequence functions	"Sq F-"	[SQF]
Control input Functions	"in F-"	[INF]
Control output functions	"outF-"	[OUTF]
Standard serial output functions	"Si F-"	[SIF]
OP-03:RS-422/485/ OP-04:RS-232C functions	"rS F-"	[RSF]
OP-07 (analog output) functions	"An F-"	[ANF]
Calibration Functions	"CALF-"	[CALF]

5-2 Function Settings

1. Enter the function setting mode.	
<input type="checkbox"/> Press [FUNC.] for 0.3 seconds or longer in the normal mode. "Function" is displayed on the sub display. * [FUNC.] will not work unless pressed for 0.3 seconds or longer. * Press [ESC] to return to the normal mode..	
2. Press a function key.	
<input type="checkbox"/> Select and press a function key from the table {5-1. General} to set or see function setting information. * If the wrong key pressed, press [ESC] and return to the normal. Example: Performing basic function setting. Press [FUNC.]. Displays show; Main display: "FncF-" / Sub display: " "	
3. Input a function number.	
<input type="checkbox"/> Input a function number with the numerical keys of [0] - [9] referring to the table {Appendix C: Function List}. * If the wrong number selected, press [ESC] and re-input. <input type="checkbox"/> Press [ENTER] to enter the setting of the function number. <input type="checkbox"/> Press [ENTER] again. The current parameters are displayed. Example: Performing FncF-02 setting. Press [2] and [ENTER] in this order for the function number "02". Displays show; Main display: "FncF- 2" / Sub display: " " Press [ENTER] again. Displays show; Main display: "FncF- 2" / Sub display: " 0" (a current value)	
4. Set a parameter to the function.	
<input type="checkbox"/> Set a parameter with the numerical keys of [0] - [9] and [+/-]. * If the wrong parameter has been typed in, press [ESC] to return to the previous value. It returns to the ready-to-input status. <input type="checkbox"/> Press [ENTER] to proceed. The next function number is displayed. <input type="checkbox"/> If more functions are to be set, set them using the procedures for step 3 and 4. Example: Setting a parameter for FncF-02=1. Press [1] for FncF-02=1. Displays show; Main display: "FncF- 2" / Sub display: " 1" (a new value) Press [ENTER], next number is displayed. Main display: "FncF- 3" / Sub display: " "	
5. Escape from the function setting mode.	
<input type="checkbox"/> Press [FUNC.] to escape from the function setting mode. Function setting data is stored in the EEPROM and returns to the normal mode. * [FUNC.] will not work when a value is displayed on the sub display. In that case press [ENTER] so that a function number is ready to be input, then press [FUNC.].	

6. WEIGHING

Section related: {Appendix C: Function List—CALF-14}

6-1 Weighing value and Set point

Weighing is performed comparing the weighing value with “Set point” values, and the weighing process is controlled by input and output signals.

Type of weighing values

There are 2 types of weighing values: Display count and internal count. (Selectable in SqF-01)

- “Display count” is the value on the display.
- “Internal count” is a high-resolution value calculated with a minimum division of 1.

Internal count has more accuracy. However in check weighing using a platform scale, “Display count” is suitable for use. Also, if the minimum division is 1, use “Display count”.

Generally, “internal count” is used in batch weighing, and “Display count” for check weighing mode.

Set point

Set point is a value to be compared with a weighing value, and the weighing process is controlled by the set point. The indicator has set points as shown below. (Differs from weighing modes)

Batch weighing Loss-in weigh Nozzle Controlled Weighing Mode	Check weighing
Final	Go
Free fall	N/A
Preliminary	Hi-Hi
Optional preliminary	Lo-Lo
Over limit	Hi
Under limit	Lo
Zero band	Zero band
Full	N/A

* Battery backs up the set point data.

* Set points can be set from keys (See {3-3.Setting and recalling set points}) and by a command in the command mode as well. (See {8-7 Command Mode—Command SSXX})

6-2 Weighing Modes

The indicator-FP has 10 weighing modes, which vary from the weighing method (normal batching or loss-in weigh) and with/without a PLC (Programmable Logic Controller).

Choose the mode suitable for your weighing at CALF-14. (See {Appendix C: Function List})

Utility	PLC.	Type of weighing		Weighing mode	Section
Hopper scale	In use 1)	Normal batching 3)		Normal batching (Customer Programmed Control Mode)	6-3
		Loss-in-weigh 4)		Loss-in-weigh (Customer Programmed Control Mode)	6-4
	Not in use 2)	Normal batching 3)	Without supplementary flow	Normal batching (Built-in automatic program mode)	6-5
			With supplementary flow	Normal batching (Built-in automatic program mode)	6-6
		Loss-in-weigh 4)		Loss-in-weigh (Built-in automatic program mode)	6-7
		Nozzle Controlled Weighing Mode 5)		Nozzle Controlled Weighing Mode (Built-in automatic program mode)	6-8
Platform Scale, Check weighing scale	In use 1)	Check weighing 6)	3-stage check weighing with Over/Under limit weight-deviation	Check weighing 1	6-9
			5-stage check weighing	Check weighing 2	6-10
			3-stage check weighing with Over/Under limit weight-deviation	Check weighing 3	6-11
			5-stage check weighing	Check weighing 4	6-12

1) PLC in use:

A programmed PLC is required besides the indicator to control the weighing process.

2) PLC not in use:

The built-in program of the indicator controls the weighing process.

3) Normal batching:

Weighs ingredient, controlling the increase in weight by comparing the measured weight with the set point weight.

4) Loss-in-weigh:

Weighs ingredient, controlling the loss in weight by comparing the measured weight with the set point weight.

5) Nozzle Controlled Weighing Mode:

Normal batching mode with tare function and nozzle control function.

6) Check weighing:

Weighs ingredient by comparing the measured weight with the target weight, and judges the result in three ranks, Hi, Go, Lo.

[Blank page]

6-3 CALF-14="1" Weighing Mode

(Normal batching in customer programmed control mode)

Output signal	Output condition
Zero band	Gross weight ≤ Zero band
Full-flow	Final - Optional preliminary ≤ Net weight
medium-flow	Final - Preliminary ≤ Net weight
Dribble-flow	Final - Free fall ≤ Net weight
Over limit	Final + Over limit < Net weight
Under limit	Net weight < Final - Under limit

- When an output condition is established, a relevant output terminal is turned on (power continuity with output COM).
- An output terminal number can be selected with OUTF-01 through OUTF-08. See {Appendix C: Function List}
- A set point signal output is turned off unconditionally when the operation mode is other than the normal mode.

Weighing process

* Programming with a PLC (Programmable Logic Controller) is required for this weighing mode.

Sequence #	Process
1	<ul style="list-style-type: none"> • The "Tare" signal is input. • The display shows "0".
2	<ul style="list-style-type: none"> • Gates G1 (full-flow), G2 (medium-flow), and G3 (dribble-flow) open. • The weight on the display is incremented, and reaches the weight of "Final – Optional preliminary". • The "Optional preliminary" output is turned ON. • Gate G1 closes.
3	<ul style="list-style-type: none"> • The display shows the weight of "Final – Preliminary". • The "Preliminary" output is turned ON. • Gate G2 closes.
4	<ul style="list-style-type: none"> • The display shows the weight of "Final – Free fall". • The "Final" output is turned ON. • Gate G3 closes. • Weighing completes at a stable display. * The display shows the final weight, indicating that hopper 2 has been filled to that weight. Use the over limit/under limit setting to check whether the weighing value is within limits.
5	<ul style="list-style-type: none"> • Gate G4 (Discharging gate) opens to discharge and fill the container. * The use of the zero range setting can check if the ingredient has been completely discharged.

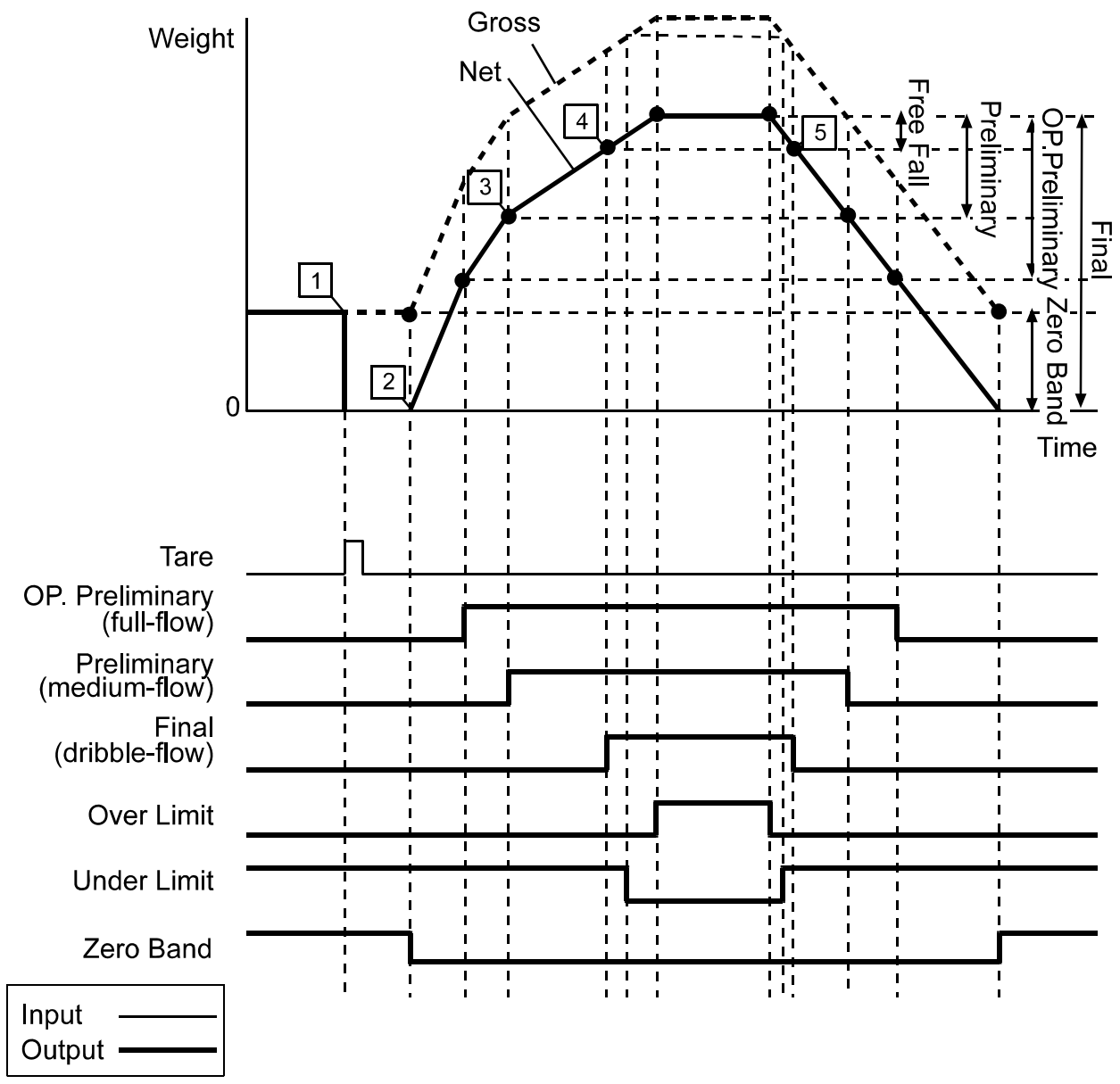
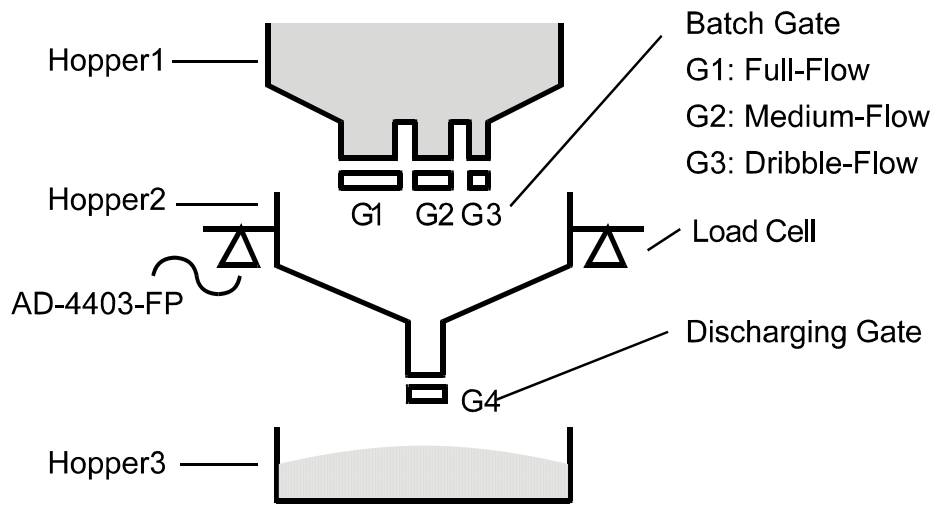

6-4 CALF-14="2" Weighing Mode

(Loss-In-weigh in customer programmed control mode)

Output signal	Output condition
Zero band	Gross weight \leq Zero band
Full	Full \leq Gross weight
Full-flow	Final - Optional preliminary \leq - Net weight
Medium-flow	Final - Preliminary \leq - Net weight
Dribble-flow	Final - Free fall \leq - Net weight
Over limit	Final + Over limit $<$ Net weight
Under limit	- Net weight $<$ Final - Under limit

- When an output condition is established, a relevant output terminal is turned on (power continuity with output COM).
- An output terminal number can be selected with OUTF-01 through OUTF-08. See {Appendix C: Function List}
- A set point signal output is turned off unconditionally when the operation mode is other than the normal mode.

Weighing process

- * Programming with a PLC (Programmable Logic Controller) is required for this weighing mode.
- * Difference from the normal batching is that the loss-in weigh has "full" output and the comparison is done with a negative net weight.

Sequence #	Process
1	<ul style="list-style-type: none"> • With the weighing hopper 2 being empty, the gross weight is within the zero range.
2	<ul style="list-style-type: none"> • Gate G1 (Filling gate) opens. • The weight on the display is incremented, and reaches the "Full" weight. • The "Full" output is turned ON. • Gate G1 closes. (Weighing hopper 2 has been filled.)
3	<ul style="list-style-type: none"> • The "Tare" signal is input. • The display shows "0".
4	<ul style="list-style-type: none"> • Gates G2 (full-flow), G3 (medium-flow), and G4 (dribble-flow) open. • The display shows the weight of "Final – Optional Preliminary". • The "Optional Preliminary" output is turned ON. • Gate G2 closes.
5	<ul style="list-style-type: none"> • The display shows the weight of "-(Final – Preliminary)". • The "Preliminary" output is turned ON. • Gate G3 closes.
6	<ul style="list-style-type: none"> • The display shows the weight of "-(Final – Free fall)". • The "Final" output is turned ON. • Gate G4 closes. • Weighing completes at a stable display. * The indicator shows the final weight(negative), indicating that hopper 3 has been filled to that weight. The use of over limit/under limit setting can check whether the weight is within limits.
7	<ul style="list-style-type: none"> • When the volume of ingredient left in the weighing Hopper 2 becomes less than the Zero band. • The "Zero band" output signal is turned on.

- * Note: SQF-21/ SQF-22 setting enables to add automatically Final weight to Zero band or Full. Therefore there is always enough ingredient left in the hopper for a measurement.

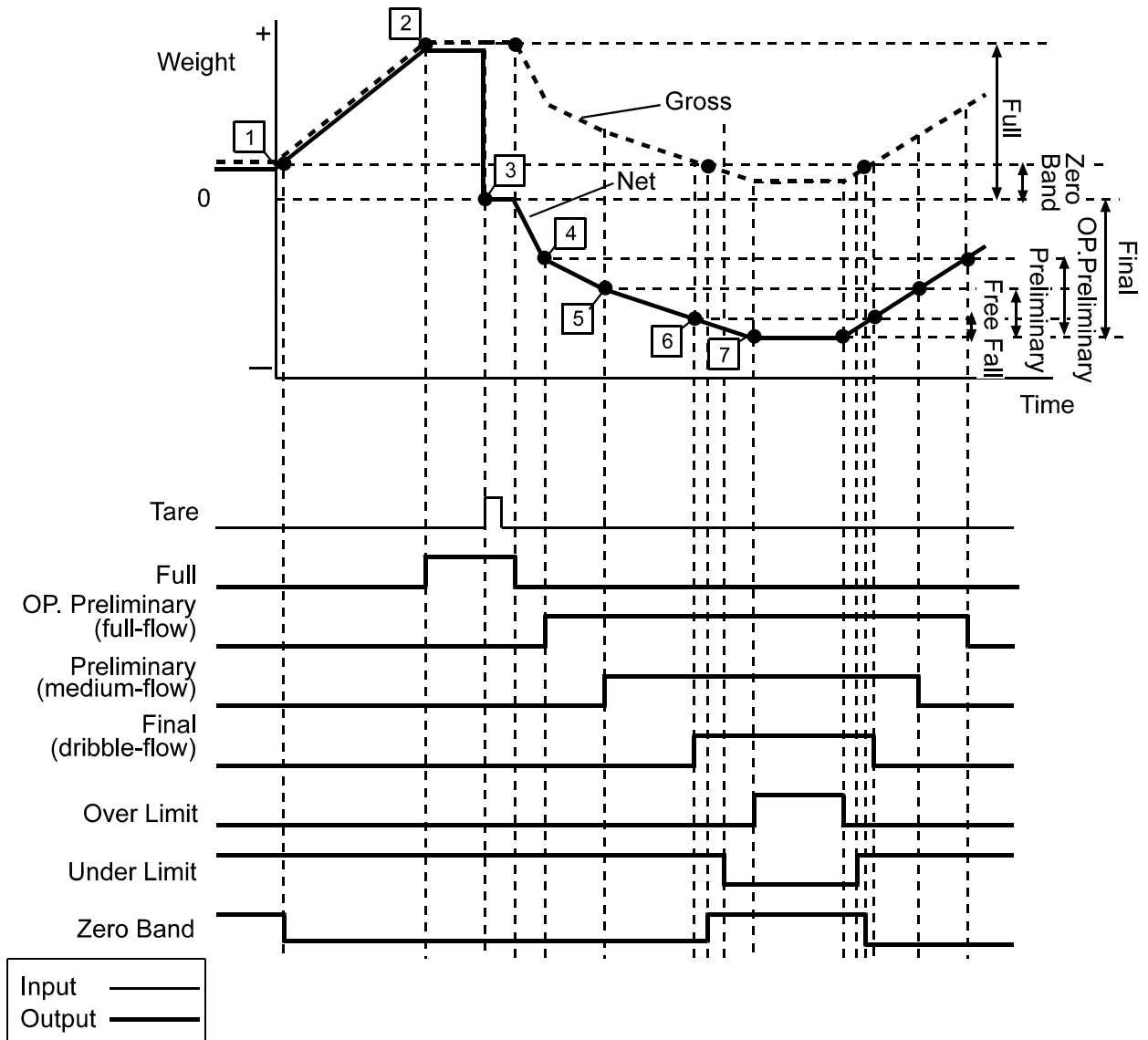
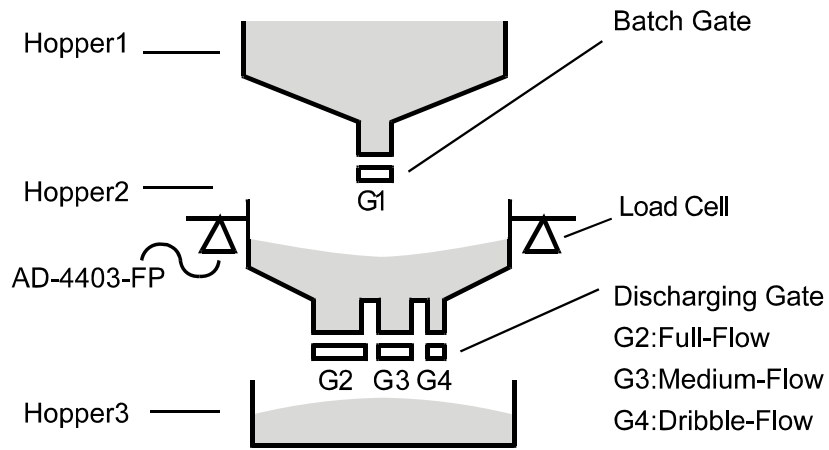

6-5 CALF-14="3" Weighing Mode (with no Supplementary Flow)

(Normal batching in built-in automatic program mode)

Output signal	Output condition
Zero band	Gross weight \leq Zero band
Full-flow	Final - Optional preliminary \leq Net weight
Medium-flow	Final - Preliminary \leq Net weight
Dribble-flow	Final - Free fall \leq Net weight
Over limit	Final + Over limit $<$ Net weight
Under limit	Net weight $<$ Final - Under limit

- When an output condition is established, full flow, medium flow, and dribble flow outputs are turned off, but the other outputs are turned on.
- Once the full flow, medium flow, and dribble flow are turned off, they are not turned on until the next start of batching.
- Over limit / Under limit is activated based on the net weight upon batch finish. (May be changed to customer programmed control mode operation)
- The zero band is a customer programmed control mode operation.

Weighing process

Sequence #	Process
1	<ul style="list-style-type: none"> • "Batch start" or "Discharge start" signal is ready to be input.
2	<ul style="list-style-type: none"> • The "Batch start" signal is input. • The "Batch start wait timer" starts.
3	<ul style="list-style-type: none"> • The "Batch start wait timer" completes the set time. • "Full-flow", "Medium-flow" and "Dribble-flow" output signals are turned on. • The "Full-flow comparator inhibitor timer" and "Batch monitoring timer" start.
4	<ul style="list-style-type: none"> • Net weight reaches the weight of "Final" –"Optional preliminary" or more. • The "Full-flow" output is turned off. • The "Medium-flow comparator inhibitor timer" start.
5	<ul style="list-style-type: none"> • Net weight reaches the weight of "Final" –"Preliminary" or more. • The "Medium-flow" signal is turned off. • The "Dribble-flow comparator inhibitor timer" starts.
6	<ul style="list-style-type: none"> • Net weight reaches the weight of "Final" –"Free fall" or more. • The "Dribble-flow" signal is turned off. • The "Judgment wait timer" starts.
7	<ul style="list-style-type: none"> • The "Judgment wait timer" completes the set time. • Display becomes stable. • If automatic free fall compensation is being used, its calculation will be made. • The "Batch Finish" output signal is turned on • If there is excess or shortage, a judgment result output signal (over limit or under limit) will be turned on. ("Within limit" is on in the chart on next page.) • The "Batch monitoring timer" is reset. • The net weight is accumulated automatically. • The data is output from the interface set for auto print.
8	<ul style="list-style-type: none"> • The "Discharge start" signal is input. • The "Discharge start wait timer" starts.
9	<ul style="list-style-type: none"> • The "Discharge start wait timer" completes the set time. • The "Discharge output" signal is turned on. • The "Discharging time monitor timer" starts.
10	<ul style="list-style-type: none"> • Gross weight reaches 0 or less. • The "Discharge valve close wait timer" starts. • The "Discharging time monitor timer" is reset.
11	<ul style="list-style-type: none"> • The "Discharge valve close wait timer" completes the set time. • The "Discharge output" signal is turned off.
12	<ul style="list-style-type: none"> • The "Batch start" input signal for the next cycle is input. • The "Batch finish" output signal is turned off. • The judgment result output signal (Over limit or Under limit) is turned off. <p>* Now, the weighing sequence has cycled and restarts from sequence # 2 at this time.</p>

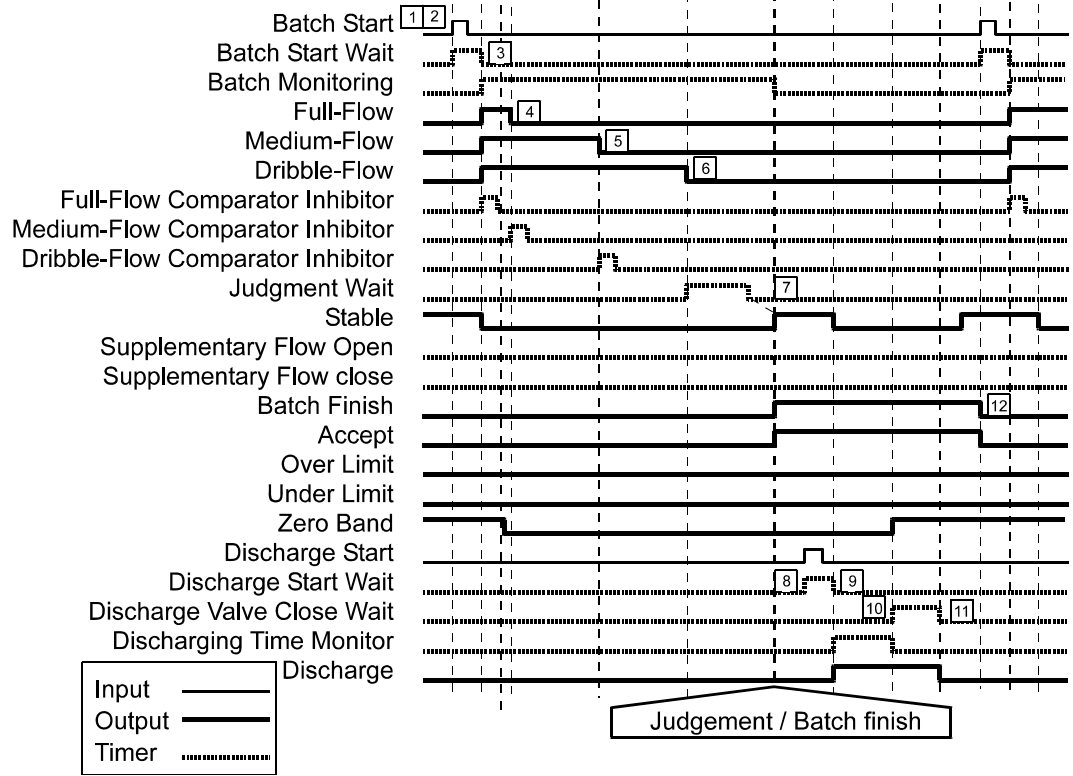
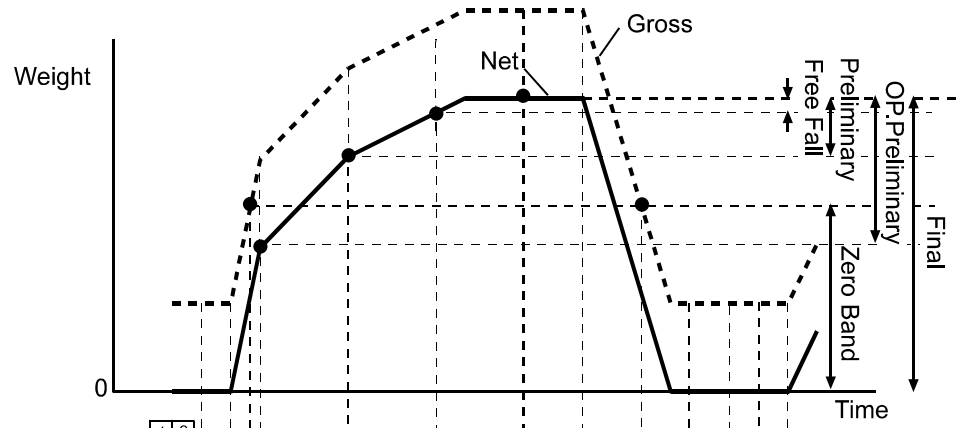
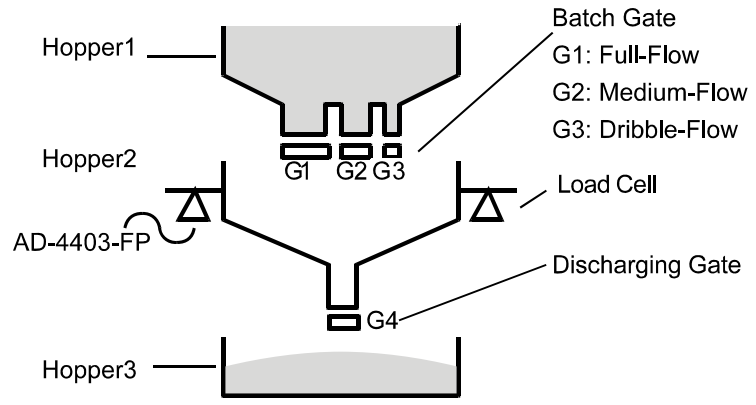

Note

- * In the case of built-in-automatic program mode weighing, the set point data is held until batch finish since batch start. Therefore, a set point altered during batching takes effect after “batch finish” is output.
- * “Within limit” is on in the chart above.

6-6 CALF-14="3" Weighing Mode (with Supplementary Flow)

(Normal batching with supplementary flow in built-in automatic program mode)

Supplementary flow automatically turns on the dribble flow for the specified time when the loaded weight is not sufficient. To make supplementary flow, set the "maximum supplementary flow times, SQF-08," to other than 0, and the "supplementary flow open timer, SQF-16," and "supplementary flow close timer, SQF-17," to their respective times. See {Appendix C: Function List}

Supplementary flow is also available in loss-in-weigh (built-in automatic program mode).

Weighing process

Sequence #	Process
1	<ul style="list-style-type: none"> • "Batch start" or "Discharge start" signal is ready to be input.
2	<ul style="list-style-type: none"> • The "Batch start" signal is input. • The "Batch start wait timer" starts.
3	<ul style="list-style-type: none"> • The "Batch start wait timer" completes the set time. • "Full-flow", "Medium-flow" and "Dribble-flow" output signals are turned on. • The "Full-flow comparator inhibitor timer" and "Batch monitoring timer" start.
4	<ul style="list-style-type: none"> • Net weight reaches the weight of "Final" –"Optional preliminary" or more. • The "Full-flow" output is turned off. • The "Medium-flow comparator inhibitor timer" start.
5	<ul style="list-style-type: none"> • Net weight reaches the weight of "Final" –"Preliminary" or more. • The "Medium-flow" signal is turned off. • The "Dribble-flow comparator inhibitor timer" starts.
6	<ul style="list-style-type: none"> • Net weight reaches the weight of "Final" –"Free fall" or more. • The "Dribble-flow" signal is turned off. • The "Judgment wait timer" and "Batch monitoring timer" start.
7	<ul style="list-style-type: none"> • The "Judgment wait timer" completes the set time. • Display becomes stable. • If automatic free fall compensation is being used, its calculation will be made. • If net weight is insufficient, the "Dribble-flow" signal will be turned on. • The "Supplementary flow timer" starts.
8	<ul style="list-style-type: none"> • The "Supplementary flow timer" completes the set time. • The "Dribble-flow" signal is turned off. • The "Supplementary flow close timer" starts.
9	<ul style="list-style-type: none"> • The "Supplementary flow close timer" completes the set time. • It is checked whether the net weight is insufficient. • If insufficient, the "Dribble-flow" signal is turned on without waiting for a stable reading. • The "Supplementary flow open timer" starts.
10	<ul style="list-style-type: none"> • The "Supplementary flow open timer" completes the set time. • The "Dribble-flow" signal is turned off. • The "Supplementary flow close timer" starts.
11	<ul style="list-style-type: none"> • The "Supplementary flow close timer" completes the set time. • It is checked whether the net weight is insufficient. • If NOT sufficient, the "Batch finish" signal is turned on without waiting for a stable reading. • A judgment result output signal (Within limit or Over limit) will be turned on. ("Within limit" is on in the chart on next page.) • The "Batch monitoring timer" is reset. • The net weight is accumulated automatically. • The data is output from the interface set for auto print.
12	<ul style="list-style-type: none"> • The "Discharge start" signal is turned on. • The "Discharge start wait timer" starts.
13	<ul style="list-style-type: none"> • The "Discharge start wait timer" completes the set time. • The "Discharge" signal is turned on. • The discharging time monitor timer starts.
14	<ul style="list-style-type: none"> • Gross weight reaches less than the weight of "Zero band". • The "Discharge valve close wait timer" starts. • The "Discharging time monitor timer" is reset.
15	<ul style="list-style-type: none"> • The "Discharge valve close wait timer" completes the set time. • The "Discharge" signal is turned off.
16	<ul style="list-style-type: none"> • The "Batch start" input signal for the next cycle is input. • The "Batch finish" output signal is turned off. • The judgment result output signal (Over limit or Under limit) is turned off. <p>* Now, the weighing sequence has cycled and restarts from sequence # 2 at this time.</p>

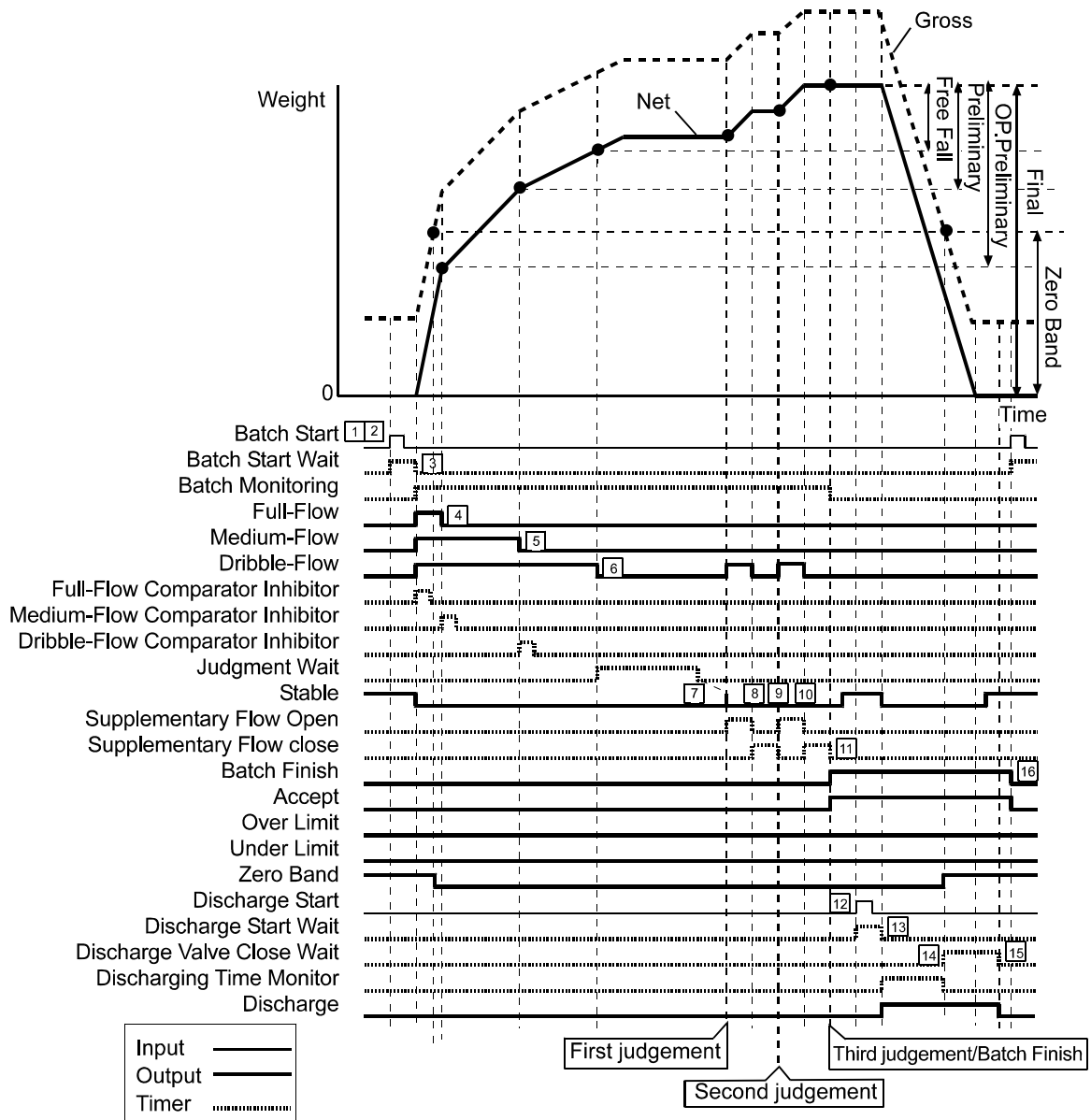
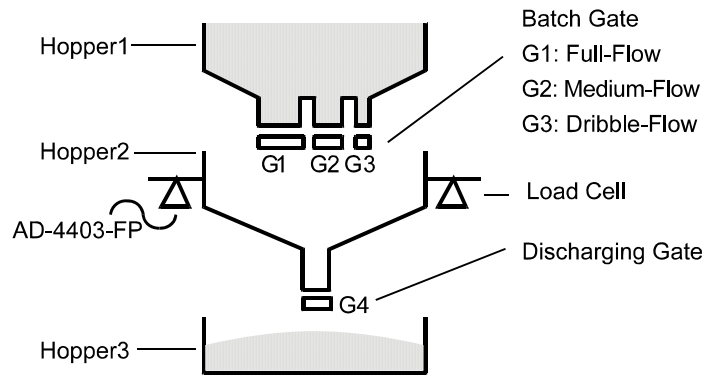

Note

- * In the case of built-in-automatic program mode weighing, the set point data is held until batch finish since start of batching. Therefore, a set point altered during batching takes effect after “batch finish” is output.
- * The chart above is the case that a judgement result becomes “Within limit” at the third judgement after supplementary flow action has been made twice.

6-7 CALF-14="4" Weighing Mode

(Loss-In-weigh in built-in automatic program mode)

Output signal	Output condition
Zero band	Gross weight \leq Zero band
Full	Full \leq Gross weight
Full-flow	Final - Optional preliminary \leq Net weight
Medium-flow	Final - Preliminary \leq Net weight
Dribble-flow	Final - Free fall \leq Net weight
Over limit	Final + Over limit $<$ Net weight
Under limit	Net weight $<$ Final - Under limit

- When an output condition is established, full flow, medium flow, and dribble flow outputs are turned off, but the other outputs are turned on.
- Once the full flow, medium flow, and dribble flow are turned off, they are not turned on until the next start of batching.
- Over limit / Under limit is activated based on the net weight upon batch finish. (May be changed to customer programmed control mode operation)
- The zero band is a customer programmed control mode operation.

Weighing process

Sequence #	Process
1	<ul style="list-style-type: none"> • The "Zero band" is output. • Ingredient continues to be supplied until the "Full" signal is output.
2	<ul style="list-style-type: none"> • The "Tare" signal is input at stable display.
3	<ul style="list-style-type: none"> • The "Batch start" signal is input. • The "Batch start wait timer" starts.
4	<ul style="list-style-type: none"> • The "Batch start wait timer" completes the set time. • "Full-flow", "Medium-flow" and "Dribble-flow" output signals are turned on. • The "Full-flow comparator inhibitor timer" and "Batch monitoring timer" start.
5	<ul style="list-style-type: none"> • Net weight reaches the weight of "Final" –"Optional preliminary". • The "Full-flow" output is turned off. • The "Medium-flow comparator inhibitor timer" starts.
6	<ul style="list-style-type: none"> • Net weight reaches the weight of "Final" –"Preliminary" or more. • The "Medium-flow" signal is turned off. • The "Dribble-flow comparator inhibitor timer" starts.
7	<ul style="list-style-type: none"> • Net weight reaches the weight of "Final" –"Free fall" or more. • The "Dribble-flow" signal is turned off. • The "Judgment wait timer" starts.
8	<ul style="list-style-type: none"> • The "Judgment wait timer" completes the set time. • Display becomes stable. • If automatic free fall compensation is being used, its calculation will be made. • The "Batch Finish" output signal is turned on • If there is excess or shortage, a judgment result output signal (Over limit or Under limit) will be turned on. ("Within limit" is on in the chart on next page.) • The "Batch monitoring timer" is reset. • The net weight is accumulated automatically. • The data is output from the interface set for auto print.

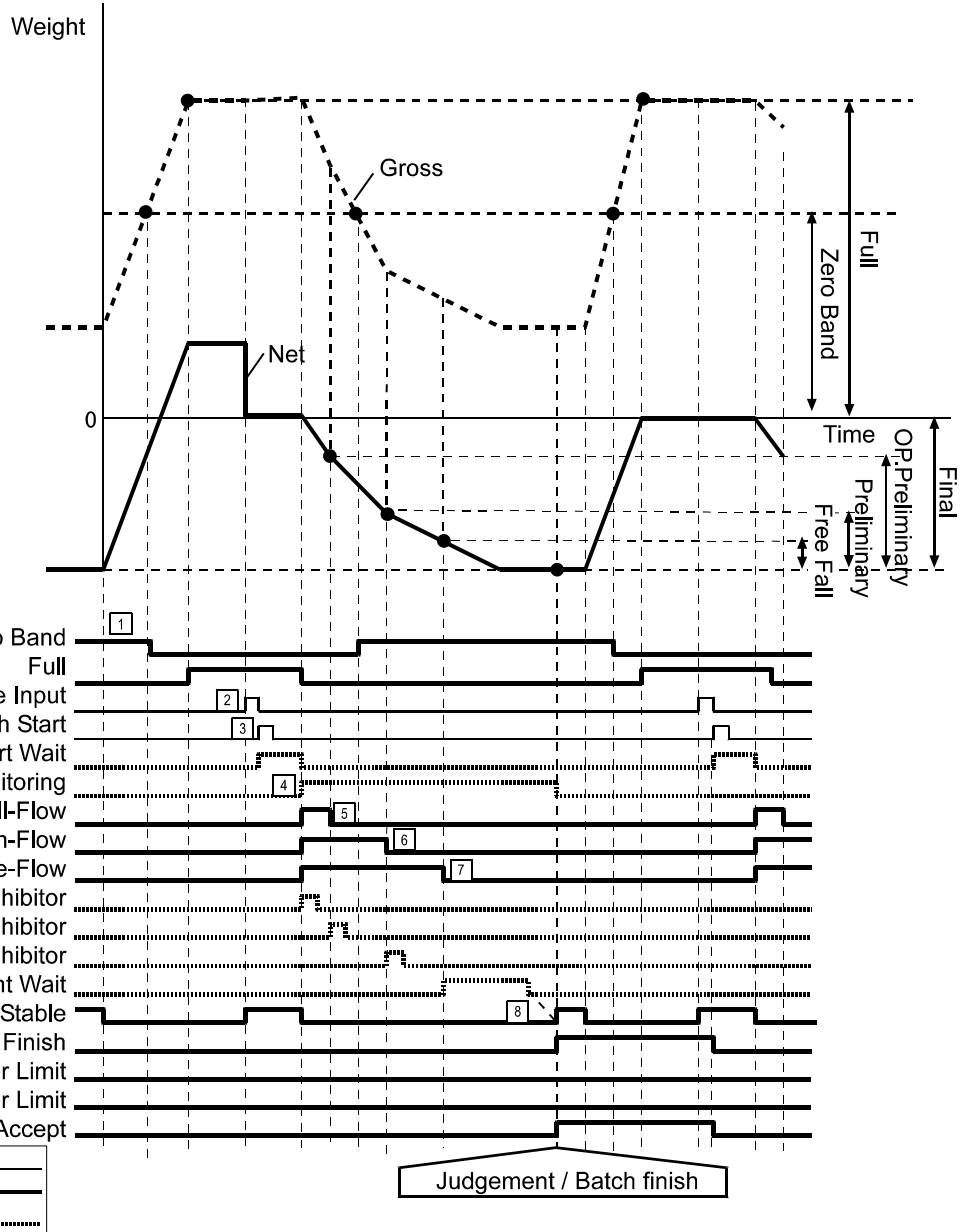
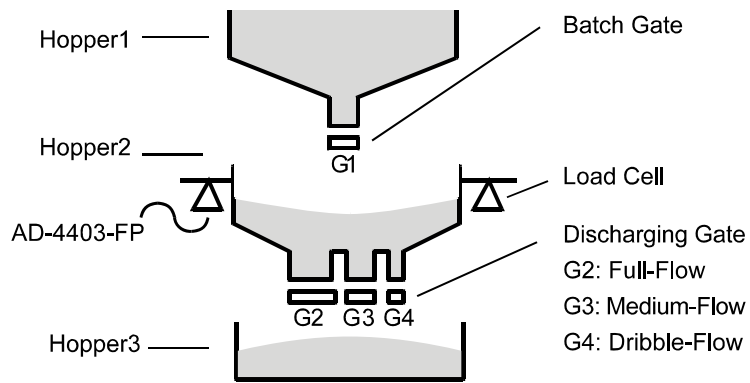

- Note**
- * SQF-21/ SQF-22 setting enables to add automatically the Final weight to Zero band or Full. Therefore there is always enough ingredient left in the hopper for a measurement.
 - * In the case of built-in-automatic program mode weighing, the set point data is held until batch finish since start of batching. Therefore, a set point altered during batching takes effect after "batch finish" is output.

6-8 CALF-14="5" Weighing Mode

(Nozzle controlled weighing mode)

Output signal	Output condition
Zero band	Gross weight \leq Zero band
Full-flow	Final - Optional preliminary \leq Net weight
Medium-flow	Final - Preliminary \leq Net weight
Dribble-flow	Final - Free fall \leq Net weight
Over limit	Final + Over limit $<$ Net weight
Under limit	Net weight $<$ Final - Under limit

- When an output condition is established, a relevant output terminal is turned on or off. "Full flow", "Medium flow", and "Dribble flow": OFF, the other outputs: ON.
- Once the full flow, medium flow, and dribble flow are turned off, they are not turned on until the next start of batching.
- Over limit / Under limit is activated based on the net weight upon batch finish. (May be changed to customer programmed control mode operation)
- The zero band is a customer programmed control mode operation.

Weighing process

#	Process	#	Process
1	<ul style="list-style-type: none"> • [ZERO] is pressed. • Gross weight becomes "0". 	<p>(Continued) In case of No supplementary flow</p> <ul style="list-style-type: none"> • Supplementary flow is not made when; <ul style="list-style-type: none"> • If SqF-09\neq"0" and judgement result is either "Acceptable weight" or "Over limit". • If SqF-09="0": No supplementary flow setting. • Net weight is judged and either "Over limit", "Acceptable weight", or "Under limit" signal is turned on based on judgement result. • The "Batch monitoring timer" is reset. • The net weight is accumulated automatically. • The data is output from the interface set for auto print. • Weighing process leads to sequence #13. <p>In case that supplementary flow is made</p> <ul style="list-style-type: none"> • Supplementary flow is made when; <ul style="list-style-type: none"> • If SqF-09\neq"0" and judgement result is "Under limit". • The "Nozzle down" signal is turned on. • The "Batch monitoring timer" starts. 	
2	<ul style="list-style-type: none"> • A container is placed on the weighing platform. 		
3	<ul style="list-style-type: none"> • [TARE] is pressed • If SqF-26="1": Tared at batch start automatically • Weight is tared at sequence # 4. Automatically. • Weight is tared. • Net weight becomes "0". 		
4	<ul style="list-style-type: none"> • The "Batch start" signal is input. • If SqF-26="1": Tared at batch start automatically • Weight is tared at the "Batch start" input. • (Tare action is the same as [TARE].) • The "Batch start wait timer" will start 1 second (time for visual inspection for the tare action) later. • The "Nozzle down" signal is turned on. • The "Batch start wait timer" starts. 		9
5	<ul style="list-style-type: none"> • The "Batch start wait timer" completes the set time. • "Full-flow", "Medium-flow" and "Dribble-flow" output signals are turned on. • The "Full-flow comparator inhibitor timer" and "Batch monitoring timer" start. 		10
6	<ul style="list-style-type: none"> • Net weight reaches the weight of "Final" –"Optional preliminary" or more. • The "Full-flow" output is turned off. • The "Medium-flow comparator inhibitor timer" starts. 		11
7	<ul style="list-style-type: none"> • Net weight reaches the weight of "Final" –"Preliminary" or more. • The "Medium-flow" signal is turned off. • The "Dribble-flow comparator inhibitor timer" starts. 		12
8	<ul style="list-style-type: none"> • Net weight reaches the weight of "Final" –"Free fall" or more. • The "Dribble-flow" signal is turned off. • The "Judgment wait timer" starts. 		
9	<ul style="list-style-type: none"> • The "Judgment wait timer" completes the set time. • Display becomes stable. (Already "Stable" in the chart on next page.) • If automatic free fall compensation is being used, its calculation will be made. • Judgement is made. 		13
		14	<ul style="list-style-type: none"> • To tare, input Tare signal or press [TARE]. • If Sq F-26="1"(Tared automatically at batch start), tare is cleared automatically within zero band.

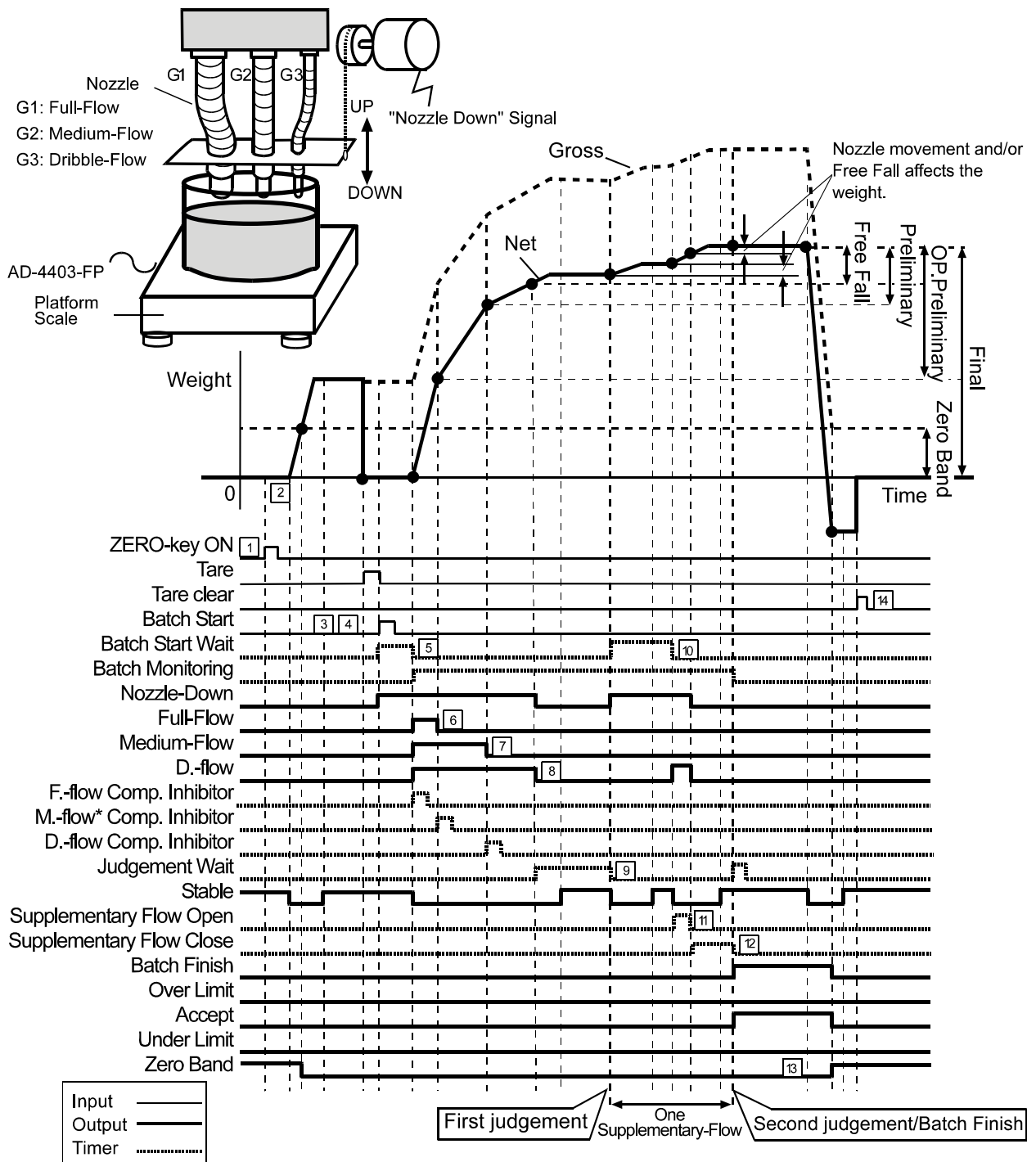

Note

- * In the case of built-in-automatic program mode weighing, the set point data is held until batch finish since start of batching. Therefore, a set point altered during batching takes effect after "batch finish" is output.
- * Chart above is of the case;
 - "Acceptable weight" is on.
 - A judgement result becomes "Acceptable weight" at the third judgement after supplementary flow action has been made twice.
- * SqF-26="0": Not tared at batch start

6-9 CALF-14=6 Weighing Mode

(Check weighing 1)

Output signal	Output condition
Zero band	Gross weight \leq Zero band
Hi-Hi	Hi-Hi limit $<$ Net weight
Hi	Target weight + Hi limit $<$ Net weight
Go	Target weight - Lo limit \leq Net weight \leq Target weight + Hi limit
Lo	Net weight $<$ Target weight - Lo limit
Lo-Lo	Net weight $<$ Lo-Lo limit

- When an output condition is established, a relevant output terminal is turned on (power continuity with the output common) or off. "Full flow", "Medium flow", and "Dribble flow": OFF, the other outputs: ON.
- Select an output terminal at the outF-01-06 setting. See {Appendix C: Function List}.
- Signal is output only in the normal mode. No output in the calibration mode nor function setting mode.

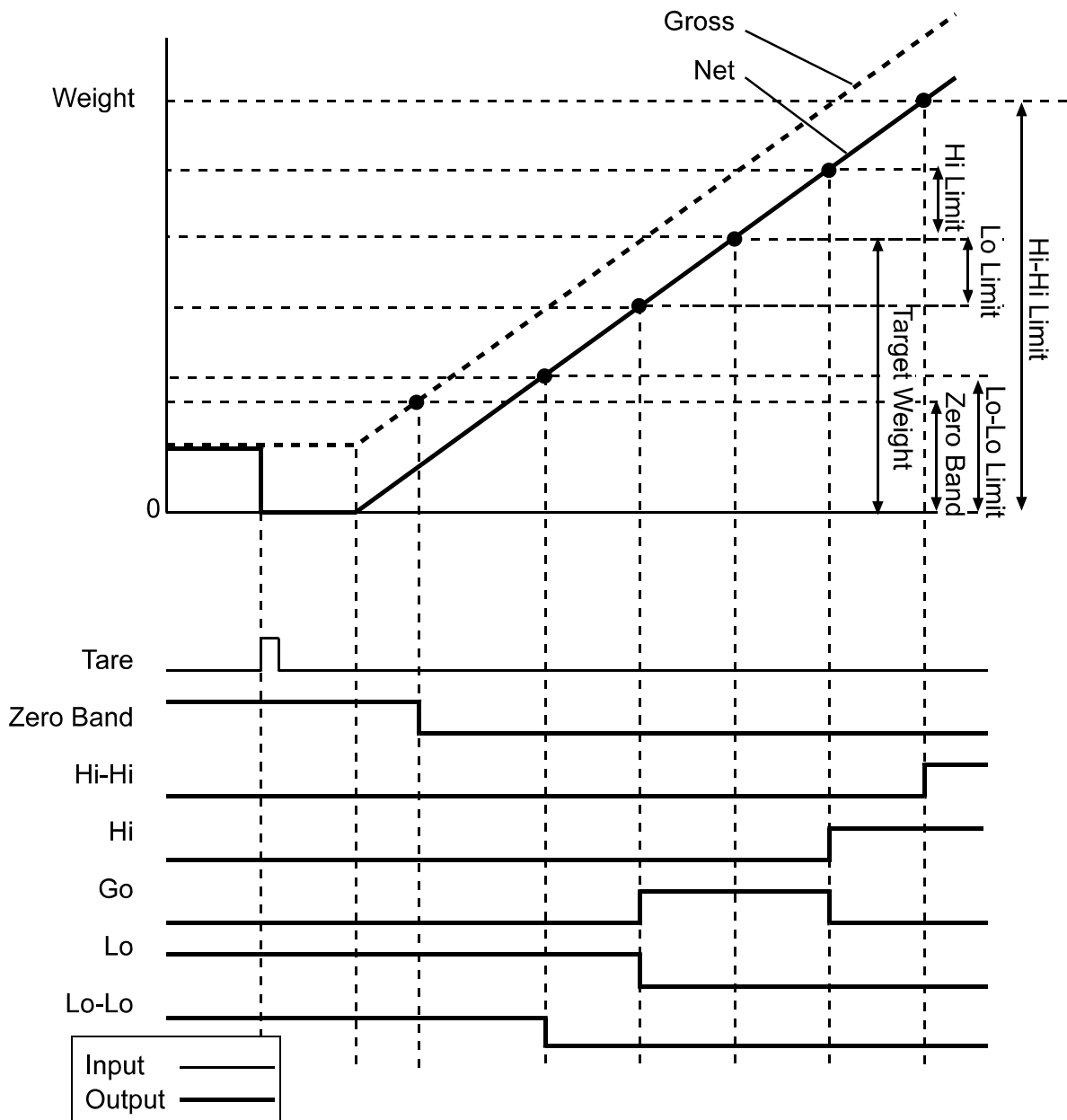

6-10 CALF-14=7 Weighing Mode

(Check weighing 2)

Output signal	Output condition
Zero band	Gross weight \leq Zero band
Hi-Hi	Target weight + Hi-Hi limit $<$ Net weight
Hi	Target weight + Hi limit $<$ Net weight \leq Target weight + Hi-Hi limit
Go	Target weight - Lo limit \leq Net weight \leq Target weight + Hi limit
Lo	Target weight - Lo-Lo limit \leq Net weight $<$ Target weight - Lo limit
Lo-Lo	Net weight $<$ Target weight - Lo-Lo limit

- When an output condition is established, a relevant output terminal is turned on (power continuity with the output common) or off. "Full flow", "Medium flow", and "Dribble flow": OFF, the other outputs: ON.
- Select an output terminal at the outF-01-06 setting. See {Appendix C: Function List}
- Signal is output only in the normal mode. No output in the calibration mode nor function setting mode.

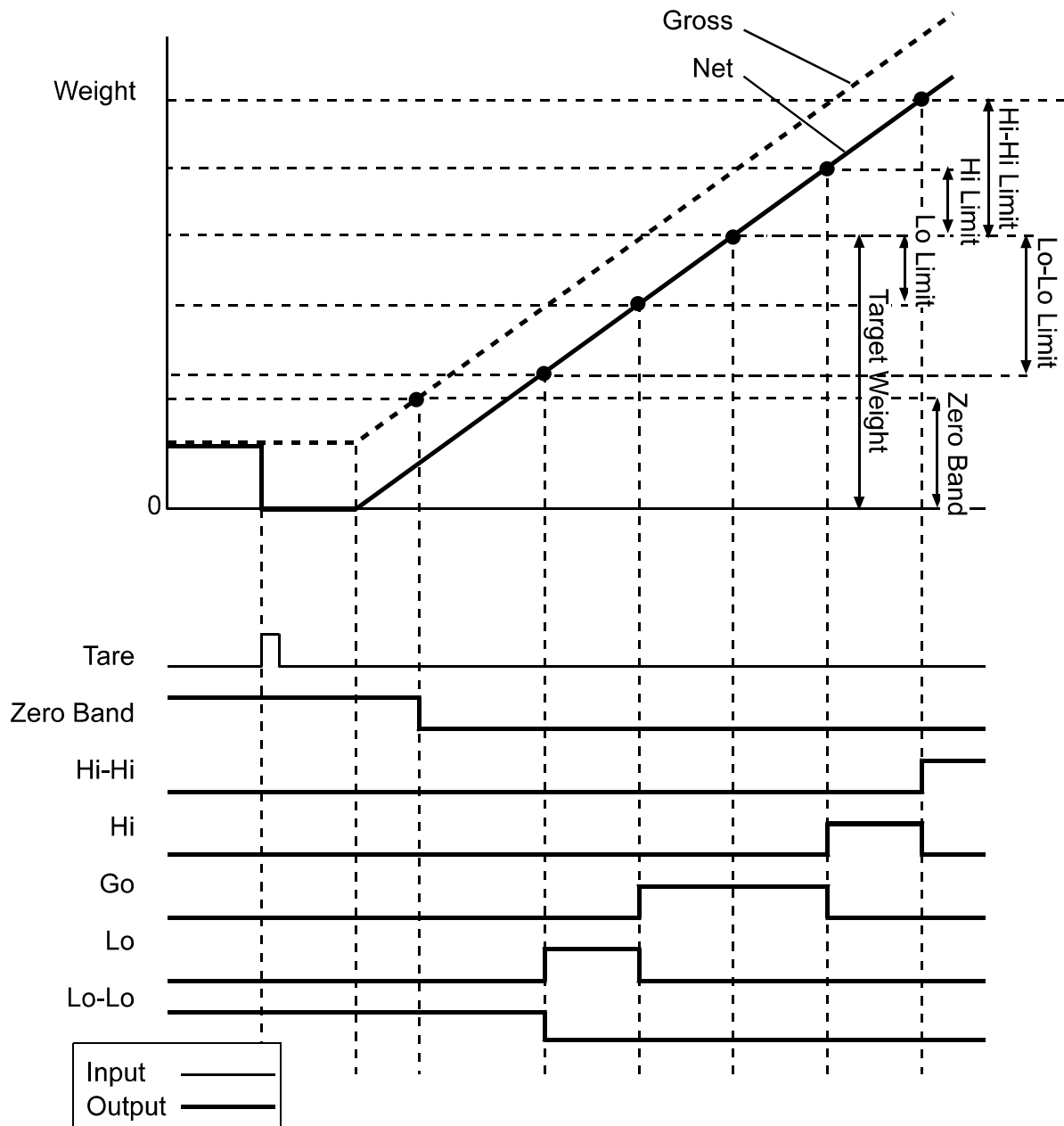

6-11 CALF-14=8 Weighing Mode

Check weighing 3)

Output signal	Output condition
Zero band	Gross weight \leq Zero band
Hi-Hi	Hi-Hi limit $<$ Net weight
Hi	Hi limit $<$ Net weight
Go	Lo limit \leq Net weight \leq Hi limit
Lo	Net weight $<$ Lo limit
Lo-Lo	Net weight $<$ Lo-Lo limit

- When an output condition is established, a relevant output terminal is turned on (power continuity with the output common) or off. "Full flow", "Medium flow", and "Dribble flow": OFF, the other outputs: ON.
- Select an output terminal at the outF-01-06 setting. See {Appendix C: Function List}.
- Signal is output only in the normal mode. No output in the calibration mode nor function setting mode.

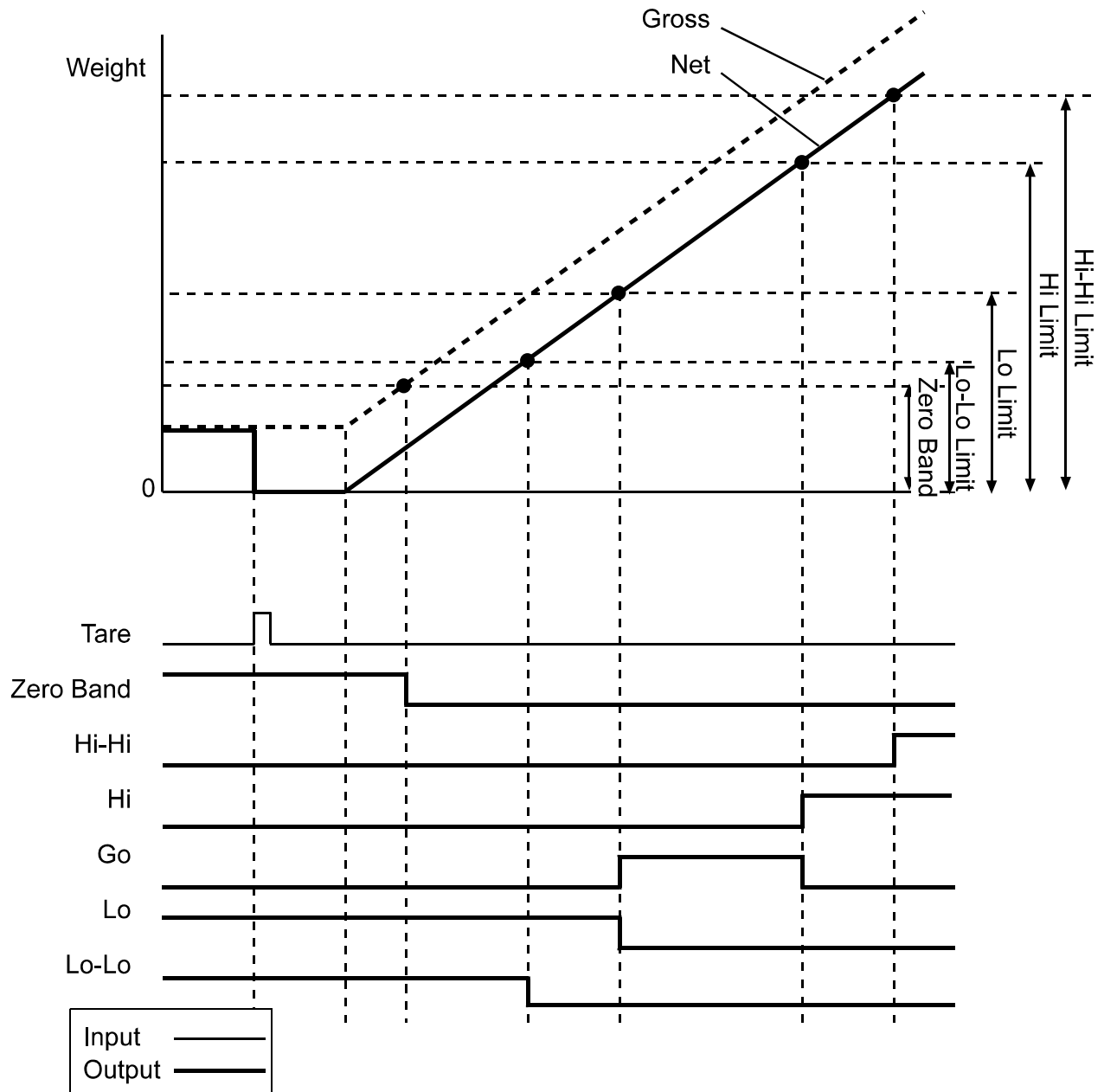

6-12 CALF-14=9 Weighing Mode

Check weighing 4)

Output signal	Output condition
Zero band	Gross weight \leq Zero band
Hi-Hi	Hi-Hi limit \leq Net weight
Hi	Hi limit \leq Net weight $<$ Hi-Hi limit
Go	Lo limit \leq Net weight $<$ Hi limit
Lo	Lo-Lo limit \leq Net weight $<$ Lo limit
Lo-Lo	Net weight $<$ Lo-Lo limit

- When an output condition is established, a relevant output terminal is turned on (power continuity with the output common) or off. "Full flow", "Medium flow", and "Dribble flow": OFF, the other outputs: ON.
- Select an output terminal at the outF-01-06 setting. See {Appendix C: Function List}.
- Signal is output only in the normal mode. No output in the calibration mode nor function setting mode.

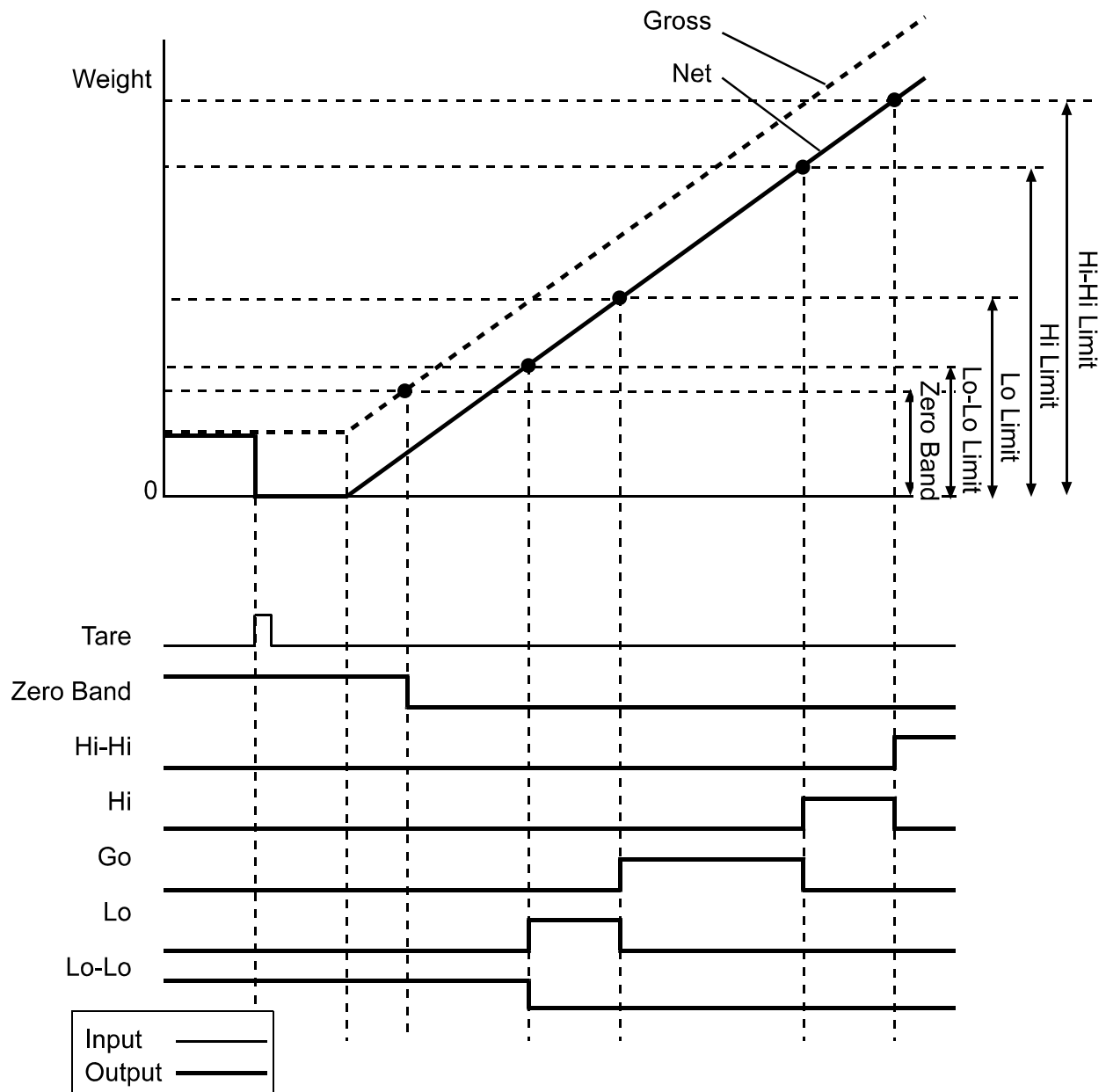

[Blank page]

7. OTHER FUNCTIONS

7-1 Auto Print

Section related: {Appendix C: Function list: SiF—Standard Serial Output Functions: SiF 02}

{Appendix C: Function list: SiF— rSF: OP-03 (RS-422/485), OP-04 (RS-232C): rSF -02}

Auto print is the capability to output the Batch Finish weight from the external output configured to “Auto Print”. The output timing depends on the weighing mode.

Weighing mode	Output timing
Customer Programmed Control Mode <ul style="list-style-type: none">• Normal batching• Loss-in-weigh	The weight is output only once when the net weight is stabilized at 5D (-5D) or greater. To output again, the weight should become less than 4D (-4D) once and again has to reach 5D or greater. * (-5D), (-4D) are for the Loss-in-weigh weighing. * D: minimum division
Check weighing	
Built-in Automatic Program Mode <ul style="list-style-type: none">• Normal batching• Loss-in-weigh• Nozzle Controlled Weighing	The weight is output at the moment when the weighing sequence encounters the batch finish timing.

7-2 Automatic Accumulation

Section related: {Appendix C: Function list: Sq F—Weighing Sequence Functions: Sq F-02}

The Automatic accumulation function automatically accumulates the net weight after weighing at the timing described above (same as auto print). Accumulation condition can be selected at Sq F-02.

7-3 Automatic Free Fall Compensation

Section related: {Appendix C: Function List

{Appendix C: Function List—Sq F: Weighing Sequence Functions, Sq F-03, 04, 29}

In batch weighing, the actual Free Fall {Weight at batch finish - (Final weight – Free Fall weight)} is not equal to the value of the Free Fall setting.

Automatic Free Fall compensation function (Sq F-03) automatically improves the accuracy in weighing by replacing the Free Fall value with the “moving average of the last four Actual Free Falls” as the next Free Fall setting

- * When the batching error (Net weight at Batch Finish – Final weight) exceeds the Automatic Free Fall Effective Width (Sq F-04), automatic Free Fall Compensations is not performed, taking it as an error.
- * Since Batch Finish is determined externally in Customer Programmed control weighing, a calculation is made assuming that weighing is completed when the [F] key is pressed or a control input signal of Automatic Free Fall command is input.
- * This function is not available for a Check Weighing.
- * Free Fall setting is updated at Batch Finish.

When a set point is recalled by code, its Free Fall setting can be stored in the memory. (Sq F-29). It enables recall of an Automatic Free Fall Compensation value of the code.

8. INTERFACE

8-1 Control Input / Output

Section related:

{Appendix C: Function List—InF: Control Input Functions}

{Appendix C: Function List—outF: Control Output Functions}

The Control Input / Output interface, consists of 6 inputs and 6 outputs, is intended for inputting/outputting weighing control signals to an external unit.

The capability of each input/output terminal can be selected at its function setting, except COM (common).

Settings

Control Input

- * A signal is accepted at the timing when the level goes from OFF to ON (Edge-Input), and when the level stays ON (Level-Input).
- * “Input ON” is a status that each input terminal is shorted to the common terminal.
- * Set 50 ms or longer for the ON time and OFF time since chattering is protected.
Input is accepted only in the normal mode. In a mode like the OFF mode, input will not be accepted to avoid wrong operations.

Control Output

- * “Output ON” is a status that each input terminal is shorted to the common terminal.
Each output terminal is turned OFF in a mode other than the normal mode to avoid wrong operations.

Specifications

Input circuit	
Maximum Input Voltage	+12 V
Maximum input current	3 mA approximately
Contact	Relay contact or Open collector

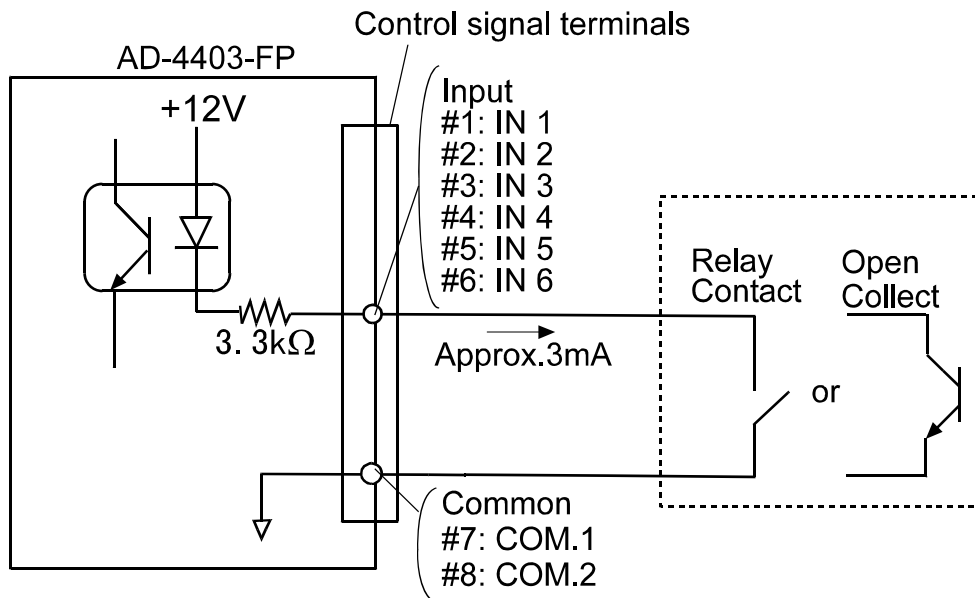

Output circuit	
Maximum input voltage	220 V AC/ 24 VDC
Maximum input current	0.5A (AC)/ 0.5A (DC)

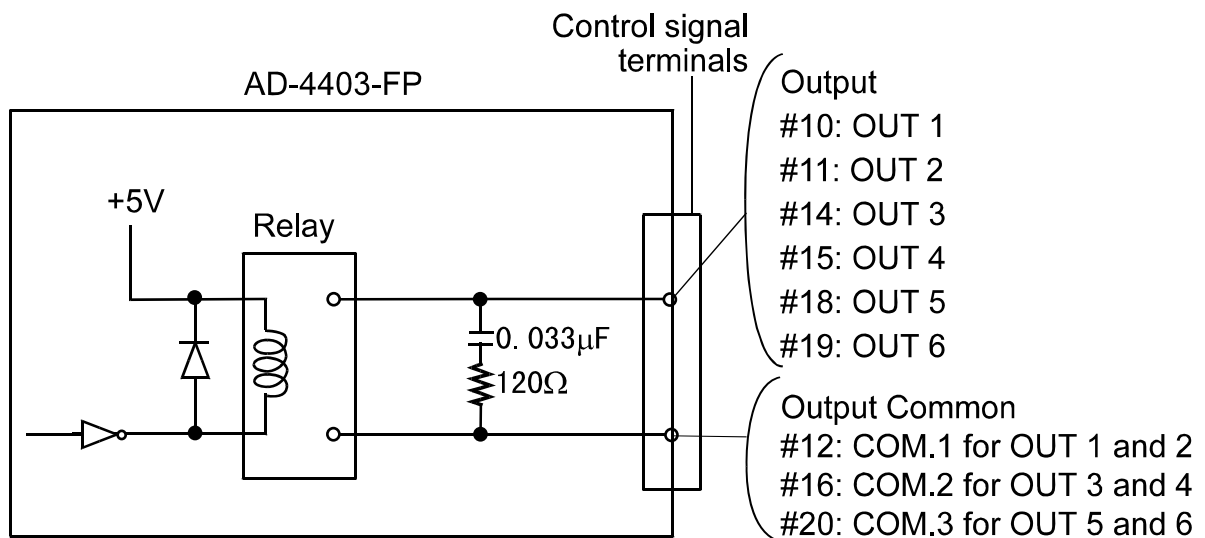

8-2 Standard Serial Output

Section related:

{8-6 Data Transmitting Format data}

{Appendix C: Function List—SiF: Standard Serial Output Functions}

The standard serial output is a 20-mA current loop interface for connection of a remote indicator or printer to the indicator. This output does not have a power supply, an external power supply is required.

Specifications

Interface Specifications	
Method	20mA current loop "1"=20mA, "0" = 0mA
Data bit	7 bits
Parity bit	1 bits (even)
Stop bit	1 bit
Code	ASCII

Circuit

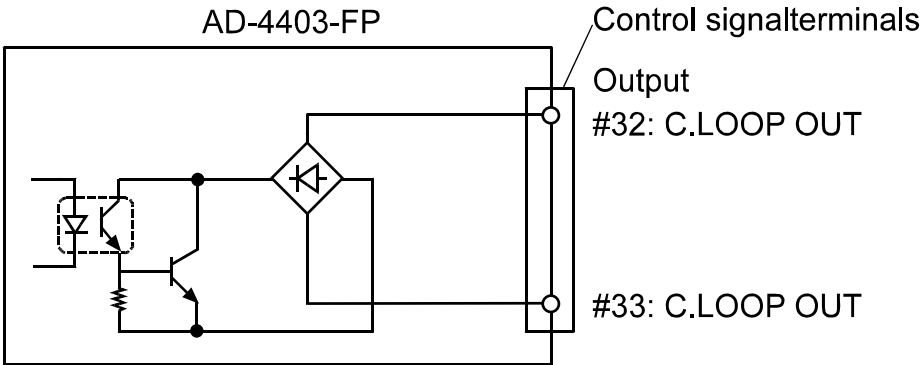

8-3 Option (OP-03: RS-422/485, OP-04: RS-232C)

Section related:

{8-6 Data Transmitting Format data}

{Appendix C: Function List— rSF: OP-03 (RS-422/485), OP-04 (RS-232C)}

OP-03 (*RS-422/485) and OP-04 (RS-232C) provides external inputs/outputs to be connected to a personal computer and other peripherals.

* OP-03 can be switched between RS-422 and RS-485.

Specifications

	OP-03:RS-422/485	OP-04:RS-232C
Interface specifications		
Method	EIA RS-422 or RS-485	EIA RS-232C
Data bit	7 bits, 8 bits	
Parity bit	1 bit (even or odd), None	
Stop bit	1 bit 2 bits	
Baud rate	600, 1200, 2400, 4800, 9600, 19200bps	
Code	ASCII	
Circuit		

Address capability (OP-03: RS-422/485)

Section related:

{Appendix C: Function List— rSF: OP-03 (RS-422/485), OP-04 (RS-232C: rSF-09)

The address capability responds only when a specific unit is called from a host computer. The address number of each unit can be set from 1 to 99 with RSF-09; 0 denotes no address capability.

When a command prefixed with an address “@xx”(xx is an address number) is sent from the host computer, each indicator compares this with the address setting of the individual instrument.

If the address matches, the command will be analyzed and responded to. At this time, the instrument’s address is added to the response.

Example of adding the address (For MZ command) @01: Address

Host	01MZ<CR><LF>
Indicator	01MZ<CR><LF>

SWITCHING TO RS-422/RS-485 (OP-03: RS-422/485)

Section related:

{Appendix C: Function List— rSF: OP-03 (RS-422/485), OP-04 (RS-232C: rSF-09, rSF-08)

Switching to RS-422/RS-485 is made with rsF-08.

To connect more than two indicators with a computer, select " Command " for RSF-02 and " With address " for RSF-09.

Example

RS-422 (RSF-08=1)

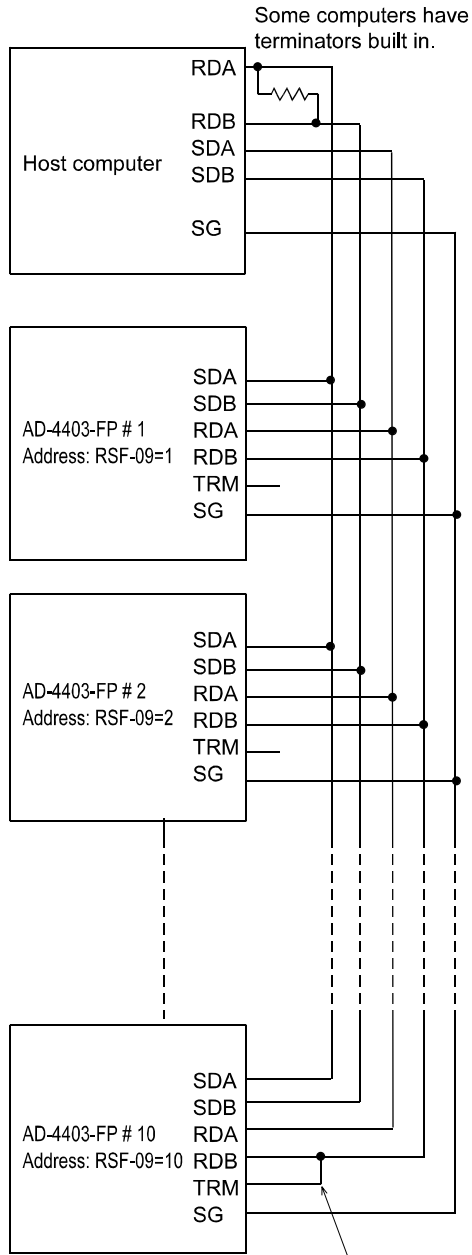

Connect a terminator to the end connection.

RS-485 (RSF-08=2)

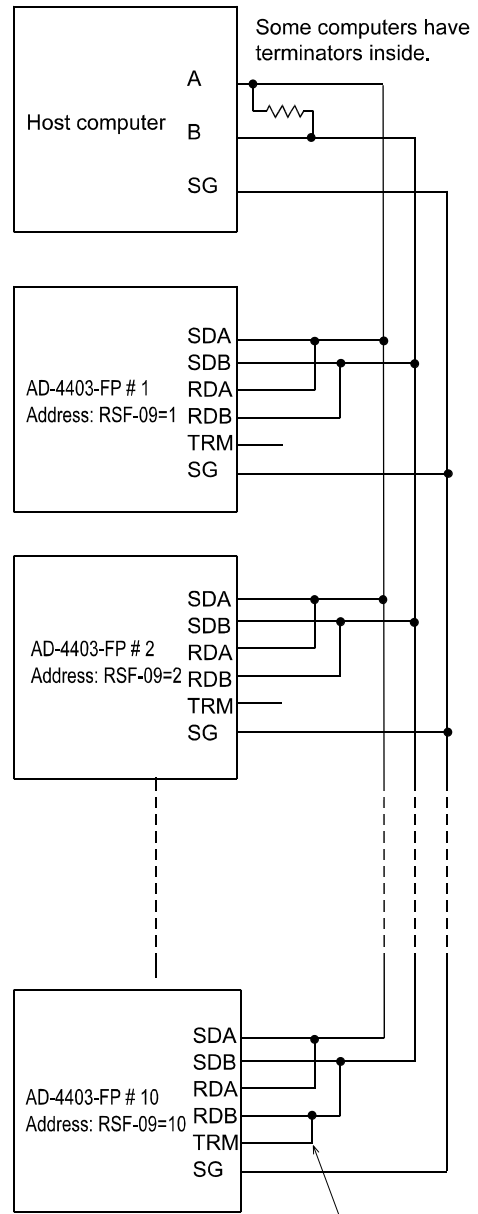

Connect a terminator to the end connection.

Note:

- * The polarity of signal A and B vary from computers.
- * Not necessary to ground the SG (Signal Ground) terminal to a computer if no SG terminal.
- * Set 8 ms or more for the SDA and SDB signal interval.

8-4 Option (OP-07 Analog Output)

Section related:

{8-6 Data Transmitting Format data}

{Appendix C: Function List— AnF: Analog Output Functions}

The OP-07 analog output option is for sending weight data to the analog input unit. The output is a 4 to 20 mA current output proportional to the display reading.

* The output data is updated in synchronization with the display update.

Interface specifications			
Output current	4 - 20 mA	Non-linearity	±0.1% FS or less
Applicable load resistance	0 - 520 Ω	Temperature coefficient	Zero: ±0.02%FS/°C or less
Resolution	1/3000 approx.		Sensitivity: ±0.02%FS/°C or less

AD-4403-FP

Control signal terminals
#22: AN.OUT+
#23: AN.OUT-
#24: F.G.

Settings

When the measured weight is expected to vary from A to B, set An F-02 to A and An F-03 to B ignoring decimal point position. Display shows weight A at 4 mA and B at 20 mA.

* Output current range: 2- 22 mA

	<Example 1 >		<Example 2 >	
Weight	A:0.0kg	B:1000.0kg	A:1000.0kg	B: 0.0kg
Function Setting	An F-02: 0.0	An F-03: 1000.0	An F-02: 1000.0	An F-03: 0.0
Output current	4mA	20mA	4mA	20mA
Graph				

8-5 Data Transmitting Mode

OP-03/04 covers all transmitting modes. However standard serial output does not.

See the table below.

Standard serial output OP-03:RS-422/485, OP-04:RS-232C	Stream	<p>The data is transmitted in synchronization with the update of the display. When the display rewrite exceeds the baud rate, data transmission is suspended until the next display update.</p> <p>The transmitted data is the same as what is being displayed. Therefore, non-displayed data is never transmitted.</p>
	Auto print	<p>The data is transmitted each time weighing has been completed. The weighing completion timing differs depending on the weighing mode. See {6. Weighing}.</p> <p>* To perform automatic accumulation and Auto Print at the same time at batch finish, set functions as below.</p> <ul style="list-style-type: none"> • Sq F-02(Automatic accumulation): “1” or “2” • SiF-02 (Data transmitting mode):“2”(Auto print) • rSF-02 (OP-03/04): “2” (Auto print)
	Manual print	<p>The data is transmitted when the “print command for manual print” is sent with the Control input.</p>
	Accumulation timing print	<p>The data is transmitted when [F] is pressed and the “print command for accumulation” is sent.</p>
	Command	<p>This mode analyzes the “command” received from the host computer, etc. provides relevant processing, and responds with a result. For example, if an “MT” command is received, the tare will be subtracted and its result (whether tare subtraction is allowed or not) will be sent as a response.</p> <p>The address capability is available only in this mode.</p>
	Output per Sampling	<p>There are two types: gross and net. This mode outputs the set point state as well as weights. This is a stream operation outputting at a rate of 100 times/second in synchronization with sampling.</p>

8-6 Data Transmitting Format

Item of data			
→Description ↓Item	ASCII code	Hex.	Description
Header1	ST	[53 54]	STable
	US	[55 53]	UnStable
	OL	[4F 4C]	OverLoad
Header2	GS	[47 53]	GroSs weight
	NT	[4E 54]	NeT weight
	TR	[54 52]	TaRe
	TW	[54 57]	Total Weight (accumulated weight)
	TN	[54 4E]	Total Number (accumulated count)
	G <i>space</i>	[47 20]	Gross weight
	N <i>space</i>	[4E 20]	Net weight
	T <i>space</i>	[54 20]	Tare
	PT	[50 54]	Preset Tare
	Header3	CD	[43 44]
Separator		[2C]	(Comma)
Data (ASCII)	0 – 9	[30 - 39]	<ul style="list-style-type: none"> • Standard data format: 8 digits including Polarity and decimal point • Accumulation data format: 11 digits including decimal point • Overflow: space (20h) filled, same decimal point position
	+	[2B]	
	-	[2D]	
	<i>space</i>	[20]	
		[2E]	
Code number	0 – 9	[30 - 39]	2 digits for a code number
	<i>space</i>	[20]	"Now in use"
Weighing unit	<i>space space</i>	[20 20]	No weighing unit
	<i>space g</i>	[20 67]	(Gram)
	kg	[6B 67]	Kg (Kilo gram)
	<i>space t</i>	[20 74]	(ton)
	lb	[6C 62]	(pound)
Terminator	CR	[0D]	Carriage Return
	LF	[0A]	Line Feed

Data format

Format Type	Format Name																																																														
Form A	A&D Standard Data Format																																																														
Standard format for A &D products like weighing indicators and printers. 18 characters in all Example (Stable, Gross weight: +12345kg)																																																															
<table border="1" style="width: 100%; border-collapse: collapse;"> <thead> <tr> <th style="width: 5%;">Head 1</th> <th style="width: 5%;"></th> <th style="width: 5%;">Head 2</th> <th style="width: 5%;"></th> <th style="width: 10%;">Data</th> <th style="width: 5%;">Unit</th> <th style="width: 5%;">Term.</th> </tr> </thead> <tbody> <tr> <td>S</td> <td>T</td> <td>,</td> <td>G</td> <td>S</td> <td>,</td> <td>+ 0 0 1 2 3 4 5</td> <td>k</td> <td>g</td> <td>C</td> <td>L</td> </tr> <tr> <td></td> <td></td> <td></td> <td></td> <td></td> <td></td> <td></td> <td>R</td> <td>F</td> <td></td> <td></td> </tr> </tbody> </table>		Head 1		Head 2		Data	Unit	Term.	S	T	,	G	S	,	+ 0 0 1 2 3 4 5	k	g	C	L								R	F																																			
Head 1		Head 2		Data	Unit	Term.																																																									
S	T	,	G	S	,	+ 0 0 1 2 3 4 5	k	g	C	L																																																					
							R	F																																																							
Form B	A&D Standard Data Format with Code Number																																																														
24 characters in all Example (Code number: 00, Unstable, Net weight: -123.45kg)																																																															
<table border="1" style="width: 100%; border-collapse: collapse;"> <thead> <tr> <th style="width: 5%;">Head 3</th> <th style="width: 5%;"></th> <th style="width: 5%;">Code</th> <th style="width: 5%;"></th> <th style="width: 5%;">Head 1</th> <th style="width: 5%;"></th> <th style="width: 10%;">Head</th> <th style="width: 5%;"></th> <th style="width: 10%;">Data</th> <th style="width: 5%;">Unit</th> <th style="width: 5%;">Term.</th> </tr> </thead> <tbody> <tr> <td>C</td> <td>D</td> <td>,</td> <td>0</td> <td>0</td> <td>,</td> <td>U</td> <td>S</td> <td>,</td> <td>T</td> <td>N</td> <td>,</td> <td>-</td> <td>0</td> <td>1</td> <td>2</td> <td>3</td> <td>.</td> <td>4</td> <td>5</td> <td>k</td> <td>g</td> <td>C</td> <td>L</td> </tr> <tr> <td></td> <td></td> <td></td> <td></td> <td></td> <td></td> <td></td> <td></td> <td></td> <td></td> <td></td> <td></td> <td></td> <td></td> <td></td> <td></td> <td></td> <td></td> <td></td> <td></td> <td></td> <td></td> <td>R</td> <td>F</td> </tr> </tbody> </table>		Head 3		Code		Head 1		Head		Data	Unit	Term.	C	D	,	0	0	,	U	S	,	T	N	,	-	0	1	2	3	.	4	5	k	g	C	L																							R	F			
Head 3		Code		Head 1		Head		Data	Unit	Term.																																																					
C	D	,	0	0	,	U	S	,	T	N	,	-	0	1	2	3	.	4	5	k	g	C	L																																								
																						R	F																																								
Form C	Accumulation Data Format																																																														
18 characters in all Example (Total Weight: +123456.7kg)																																																															
<table border="1" style="width: 100%; border-collapse: collapse;"> <thead> <tr> <th style="width: 5%;">Head 1</th> <th style="width: 5%;"></th> <th style="width: 10%;">Data</th> <th style="width: 5%;">Unit</th> <th style="width: 5%;">Term.</th> </tr> </thead> <tbody> <tr> <td>T</td> <td>W</td> <td>,</td> <td>+</td> <td>0</td> <td>0</td> <td>1</td> <td>2</td> <td>3</td> <td>4</td> <td>5</td> <td>6</td> <td>.</td> <td>7</td> <td>k</td> <td>g</td> <td>C</td> <td>L</td> </tr> <tr> <td></td> <td></td> <td></td> <td></td> <td></td> <td></td> <td></td> <td></td> <td></td> <td></td> <td></td> <td></td> <td></td> <td></td> <td></td> <td></td> <td></td> <td></td> <td></td> </tr> </tbody> </table>		Head 1		Data	Unit	Term.	T	W	,	+	0	0	1	2	3	4	5	6	.	7	k	g	C	L																																							
Head 1		Data	Unit	Term.																																																											
T	W	,	+	0	0	1	2	3	4	5	6	.	7	k	g	C	L																																														
18 characters in all Example (Total Number: 1200000, SP: space)																																																															
<table border="1" style="width: 100%; border-collapse: collapse;"> <tbody> <tr> <td>T</td> <td>N</td> <td>,</td> <td>+</td> <td>0</td> <td>0</td> <td>0</td> <td>1</td> <td>2</td> <td>0</td> <td>0</td> <td>0</td> <td>0</td> <td>0</td> <td>S</td> <td>S</td> <td>C</td> <td>L</td> </tr> <tr> <td></td> <td></td> <td></td> <td></td> <td></td> <td></td> <td></td> <td></td> <td></td> <td></td> <td></td> <td></td> <td></td> <td></td> <td>P</td> <td>P</td> <td>R</td> <td>F</td> </tr> </tbody> </table>		T	N	,	+	0	0	0	1	2	0	0	0	0	0	S	S	C	L															P	P	R	F																										
T	N	,	+	0	0	0	1	2	0	0	0	0	0	S	S	C	L																																														
														P	P	R	F																																														
Form D	Accumulation Data Format with Code Number																																																														
24 characters in all Example (Code number: 01, Total Weight: Positive-Overflow, SP: space)																																																															
<table border="1" style="width: 100%; border-collapse: collapse;"> <thead> <tr> <th style="width: 5%;">Head</th> <th style="width: 5%;"></th> <th style="width: 5%;">Code</th> <th style="width: 5%;"></th> <th style="width: 5%;">Head 1</th> <th style="width: 5%;"></th> <th style="width: 10%;">Data</th> <th style="width: 5%;">Unit</th> <th style="width: 5%;">Term.</th> </tr> </thead> <tbody> <tr> <td>C</td> <td>D</td> <td>,</td> <td>0</td> <td>1</td> <td>,</td> <td>T</td> <td>W</td> <td>,</td> <td>+</td> <td>S</td> <td>S</td> <td>S</td> <td>S</td> <td>S</td> <td>S</td> <td>S</td> <td>S</td> <td>S</td> <td>S</td> <td>.</td> <td>S</td> <td>k</td> <td>g</td> <td>C</td> <td>L</td> </tr> <tr> <td></td> <td></td> <td></td> <td></td> <td></td> <td></td> <td></td> <td></td> <td></td> <td></td> <td>P</td> <td>P</td> <td>P</td> <td>P</td> <td>P</td> <td>P</td> <td>P</td> <td>P</td> <td>P</td> <td>P</td> <td>P</td> <td></td> <td></td> <td></td> <td></td> <td>R</td> <td>F</td> </tr> </tbody> </table>		Head		Code		Head 1		Data	Unit	Term.	C	D	,	0	1	,	T	W	,	+	S	S	S	S	S	S	S	S	S	S	.	S	k	g	C	L											P	P	P	P	P	P	P	P	P	P	P					R	F
Head		Code		Head 1		Data	Unit	Term.																																																							
C	D	,	0	1	,	T	W	,	+	S	S	S	S	S	S	S	S	S	S	.	S	k	g	C	L																																						
										P	P	P	P	P	P	P	P	P	P	P					R	F																																					
24 characters in all Example (Code number: 01, Total Number: Positive-Overflow, SP: space)																																																															
<table border="1" style="width: 100%; border-collapse: collapse;"> <tbody> <tr> <td>C</td> <td>D</td> <td>,</td> <td>0</td> <td>1</td> <td>,</td> <td>T</td> <td>N</td> <td>,</td> <td>+</td> <td>S</td> <td>S</td> <td>S</td> <td>S</td> <td>S</td> <td>S</td> <td>S</td> <td>S</td> <td>S</td> <td>S</td> <td>S</td> <td>S</td> <td>S</td> <td>S</td> <td>S</td> <td>C</td> <td>L</td> </tr> <tr> <td></td> <td></td> <td></td> <td></td> <td></td> <td></td> <td></td> <td></td> <td></td> <td></td> <td>P</td> <td>P</td> <td>P</td> <td>P</td> <td>P</td> <td>P</td> <td>P</td> <td>P</td> <td>P</td> <td>P</td> <td>P</td> <td>P</td> <td>P</td> <td>P</td> <td>P</td> <td>P</td> <td>R</td> <td>F</td> </tr> </tbody> </table>		C	D	,	0	1	,	T	N	,	+	S	S	S	S	S	S	S	S	S	S	S	S	S	S	S	C	L											P	P	P	P	P	P	P	P	P	P	P	P	P	P	P	P	R	F							
C	D	,	0	1	,	T	N	,	+	S	S	S	S	S	S	S	S	S	S	S	S	S	S	S	C	L																																					
										P	P	P	P	P	P	P	P	P	P	P	P	P	P	P	P	R	F																																				

Format Type				Format Name							
Form H				Weighing Condition Read-Out Format							
Example											
Positive Overflow, Weight Data: 7FFFFFFF											
Set Point data			Weighing data 6 digits, hexadecimal						Terminator		
30	30	30	37	46	46	46	46	46	CR	LF	
		0	0	1	1	X	X	X	X		
	Fixed	Fixed	Fixed	Fixed	Batch Finish	Discharge Gate Open	Dribble-flow (Lo Lo)	Medium-flow (Lo)			
	0	0	1	1	X	X	X	X			
	Fixed	Fixed	Fixed	Fixed	Nozzle Down	Over limit	Accept				
	0	0	1	1	0	X	X	X			
	Fixed	Fixed	Fixed	Fixed	Full-flow (Go)	Over limit (Hi)	Under limit (Hi Hi)	Zero band			

Weighing data
Weighing data is described in 6-digit hexadecimal ignoring decimal point.
999.9 kg → 00270F (Hex)
-0.1 kg → FFFFFFFF (Hex)

* Set baud rate for 192000 bps.

8-7 Command Mode

The indicator receives a command transmitted from a peripheral unit like a computer in the communication procedure shown below, and operates in compliance with the command and responds with a result.

- * The communication procedure depends on the type of command.
- * When the command is not accepted due to an error (improper command or faulty data), a “negative acknowledgment” is made.

Communication procedure

Procedure	Response to Acceptable Commands
Procedure A	Host command
	Indicator command Returns the same command as the one sent from the host for a sign of the acknowledgement.
Procedure B	Host command
	Indicator data Returns the data that the command requested.
Procedure C	Host command data
	Indicator command data Returns the same command for a sign of the acknowledgement, and sends the requested data with terminators, CR or CR LF (selectable at RSF-07)
Procedure D	Host command
	Indicator data data ... data EOF Returns all the requested data. Each command differs in the number of output data Press [ESC] to stop the data flow in the middle.

Response

- * Any response to a command is made within 200 ms after receiving the command.

Type	Response
Acknowledgement	Procedure A Returns the same command.
	Procedure B, D Returns the data.
	Procedure C Returns the same command and waits to receive the data.
Negative Acknowledgement: Improper mode <small>Not acceptable because of a wrong mode.</small>	IE
Negative Acknowledgement: Improper Range <small>Not acceptable because data is out of the range.</small>	VE
Negative Acknowledgement: Improper Command / Data <small>Not acceptable because of a wrong data format</small>	?E

Commands

* See {8-6 Data Transmitting Format —Data Format} for “Data Format”.

* See {8-7 Command Mode— Communication procedure} for “Procedure”.

Command	Command name	Function	Procedure	Data Format
RW	(Request Weight)	Recalls the weight	B	A/B
<ul style="list-style-type: none"> The content of the response data is the same as that set with RSF-01. Same operation as when the manual print key is pressed. 				
MZ	(Make Zero)	Zero clear	A	
MT	(Make Tare)	Subtracts the tare	A	
Subtracts the tare. Display shows the net weight.				
MN	(Make Net)	Changes from Gross to Net display	A	
MG	(Make Gross)	Changes from Net to Gross display	A	
CT	(Clear Tare)	Tare clear	A	
AM	(Acc.Memory)	Accumulates weight/count	A	
CA	(Cancel Acc.)	Cancels accumulation	A	
Subtracts the previous weight/count from the accumulated data.				
SSXX	(Set Set points)	Sets set points to the code designated by XX	C	E
<ul style="list-style-type: none"> When no code designated (blank), set points now in use are set. Set point data length: 7 bytes including polarity. 				
RSXX	(Request Set point)	Recalls set points from the code designated by XX	B	E
When no code designated (blank), set points now in use are recalled.				
CCXX	(Change Code)	Recalls the code number designated by XX	A	
BB	(Begin Batch)	Begins batch	A	
<ul style="list-style-type: none"> This command is available only in the built-in automatic program mode weighing. If used in other weighing mode, "IE" will be transmitted. 				
BD	(Begin Discharged)	Begins discharge	A	
<ul style="list-style-type: none"> This command is available only in the built-in automatic program mode weighing. If used in other weighing mode, "IE" will be transmitted. 				

* See {8-6 Data Transmitting Format —Data Format} for “Data Format”.

* See {8-7 Command Mode— Communication procedure} for “Procedure”.

Command	Command name	Function	Procedure	Data Format
HB	(Halt Batch)	Halt batch in an emergency	A	
<ul style="list-style-type: none"> • This command is available only in the built-in automatic program mode weighing. • In other weighing mode, "IE" will be transmitted. 				
RF	(Request Final)	Recalls the final weight	B	A/B
Outputs the net weight at batch finish.				
RB	(Req.Batch status)	Recalls the weighing sequence status	B	H
RTXX	(Request Total)	Recalls the accumulated data of the code designated by XX	B	C/D
<ul style="list-style-type: none"> • When no code designated (blank), total accumulated weight and the total accumulated count will be recalled. 				
DTXX	(Delete Total)	Clears the accumulation data of the code designated by XX	A	
When no code designated (blank), total accumulated weight and the total accumulated count will be deleted.				
ET	(Erase Total)	Clears the accumulation data of all the codes	A	
Both total accumulated weight and total accumulated count are also cleared.				
RE	(Read EEPROM)	Recalls the data from the EEPROM	B	
<ul style="list-style-type: none"> • The EEPROM stores data related to calibration and functions. • The data read out with this command can be exported to other Indicator with the "WE" command • This command is available only when "CAL SET" is displayed in the calibration mode. • Data length: 308 characters, ASCII code (terminators not included.) 				
WE	(Write EEPROM)	Writes data (calibration, function) into the EEPROM	C	
This command is available only when "CAL SET" is displayed in the calibration mode.				
RC	(Read Code)	Recalls the data of all the codes	B	G
<ul style="list-style-type: none"> • Set point and accumulation data of the code are read out from the RAM. • The data of the code number from "0" to "99" and the set point data now in use are output in this order. • This command is available only when "opErAtE" is displayed in the set point editing mode. 				
WC XX	(Write Code)	Write data to the code number designated by XX	C	G
This command is available only "opErAtE" is displayed in the set point editing mode.				
RD	(Read function Data)	Recalls all the function data	D	F
This command is available only when "opErAtE" is displayed in the set point editing mode.				
WD	(Write function Data)	Write a function data to the designated code	C	F
This command is available when "opErAtE" is displayed in the set point editing mode.				

Programming in RS-422

* Example: Recalls the weighing data from two indicators.

Settings		
Personal computer		
Baud rate	9600bps	
Parity	Even	
Character bit length	7 bits	
Stop bit length	1 bit	
Terminator	CR,LF	
Indicator		
Baud rate	9600bps	rSF-03=5
Parity	Even	rSF-04=2
Character bit length	7 bits	rSF-05=7
Stop bit length	1 bit	rSF-06=1
Terminator	CR,LF	rSF-07=2
Output data	Displaying weight	rSF-01=1
Data transmitting mode	command	rSF-02=5
RS-422/485 switching	RS-422	rSF-08=1
Address number	1 and 2	rSF-09=1,2

```

10  OPEN "COM:E71NN" AS #1      RS-422C setting
20  PRINT #1,"@01RW"           Requests the weight to unit #1.
30  LINE INPUT #1,A1$          Unit #1 acknowledges the request.
40  PRINT A1$                   Unit #1 responds.
50  FOR I=1 TO 100: NEXT I     Waits to avoid conflicts among others.
60  PRINT #1,"@02RW"           Requests the weight to unit #2.
70  LINE INPUT #1,A2$          Unit #2 acknowledges the request.
80  PRINT A2$                   Unit #2 responds.
90  CLOSE
100 END

```

Programming in RS-232C

Settings		
Personal computer		
Baud rate	9600bps	
Parity	Even	
Character bit length	7 bits	
Stop bit length	1 bit	
Terminator	CR,LF	
Indicator		
Baud rate	9600bps	rSF-03=5
Parity	Even	rSF-04=2
Character bit length	7 bits	rSF-05=7
Stop bit length	1 bit	rSF-06=1
Terminator	CR,LF	rSF-07=2
Output data	Displaying weight	rSF-01=1
Data transmitting mode	command	rSF-02=5
Address number	None	rSF-09=0

```

10    OPEN "COM:E71NN" AS #1          RS-232C setting
20    PRINT #1,"RW"                   Requests the weight to the Indicator.
30    LINE INPUT #1,A1$               The unit acknowledges the request.
40    PRINT A1$                       The unit responds.
50    CLOSE
60    END

```

[Blank page]

9. MAINTENANCE

9-1 System check

Check items

Following 12 items can be checked in this check mode.

Display in the check mode	Check item
"Chc PrG"	Program version
"Chc Ad"	A/D converter
"Chc KEy"	Key switches
"Chc LEd"	Display
"Chc buZ"	Buzzer
"Chc EEP"	EEPROM
"Chc bAt"	Lithium battery
"Chc si"	Standard serial output
"Chc in"	Control input
"Chc Out"	Control output
"Chc rS"	RS-232C/422/485
"Chc An"	Analog output

General procedures

1. Enter the check mode	
<input type="checkbox"/>	To enter the check item selecting mode, press [ZERO] while pressing [ENTER], then press [ENTER] again. It shows; Main display: "Chc PrG" Sub display: " "
*	Press [ESC] to return to the normal mode.
2. Select a check item from the above table	
<input type="checkbox"/>	Select an item with [F] (Forward) and [FUNC.] (Backward) and press [ENTER] to move to the selected item.
3. Check the system	
See the following {Each check item} and check the system.	

Each check item

Display	Check Item		
"Chc PrG"	Program Version		
<p>This check displays the version of the program stored in the ROM. The version number is displayed as "vEr X.XX".</p> <p>* Press [ESC] to return to the check item-selecting mode.</p>			
"Chc Ad"	A/D Converter		
<p>The load cell Input voltage is displayed in the unit of mV/V. Applying offset voltage to the load cell can check the A/D Converter function.</p> <p>Keep the record of the input voltage for future maintenance work.</p> <p><input type="checkbox"/> Apply some voltage with [F] and [ENTER] . "□" should move upward when applied,.</p> <p>* Press [ESC] to return to the check item-selecting mode.</p>			
#	Problem	Cause	
1	With +SIG and -SIG Load Cell terminals shorted, 0.0 mV/V is not displayed.	<ul style="list-style-type: none"> • Incorrect wiring • Not sufficient input voltage • Damaged A/D converter 	
2	When not loaded, the displayed value is out of a range of 0.0 mV/V to 2.0 mV/V.	<ul style="list-style-type: none"> • Incorrect rate of load cell • Damaged load cell 	
3	When loaded, the displayed value is smaller than that of # 2, or larger than 3.2 mV/V.	<ul style="list-style-type: none"> • Incorrect wiring • Incorrect rate of load cell 	
4	"□" moves upward when [F] or [ENTER] pressed. However no increase in value on the display.	<ul style="list-style-type: none"> • Incorrect wiring 	
"Chc KEY"	Key Switches		
Key number assignment			
[1] ZERO	[2] TARE	[3] NET GROSS	[4] ON OFF
[5] UNDER ANF	[6] OVER CAL	[7] PRESET TARE	[8] SET POINT
[9] OP. PRELIM OUTF	[10] ZERO BAND SIF	[11] FULL RSF	[12] FUNC.
[13] FINAL F N	[14] FREE FALL SQF	[15] PRELIM INF	[16] F
[17] CODE	[18] +/-	[19] ESC	[20] ENTER
		<p>Front panel key</p> <p><input type="checkbox"/> Pressing a key shows a relevant number (see the key number assignment on the left.) The number is displayed as "no.XX". ([FUNC.] displays "no.12")</p> <p>Left keypad is of type A model. However key number assignment is same between type A and B.</p> <p>Calibration disable switch</p> <p><input type="checkbox"/> Switching the calibration disable switch to the ON position or OFF. ON: "S1" OFF: " " (blank)</p> <p>* To return to the check item-selecting mode, press [ESC] a little longer (more than 0.3 seconds)</p> <p>* When no switch is pressed, "OFF" is displayed.</p> <p>* If two or more switches are pressed, "Err" is displayed.</p>	

Display	Check Item
"Chc LED"	LEDs
<input type="checkbox"/> Pressing [F] or [ENTER] shows a relevant number of the LED as "no. XX" and illuminates the LED. * To return to the check item-selecting mode, press [ESC].	
LED	Display
SET POINT	"no. 1"
TOTAL	"no. 2"
ACCEPT	"no. 3"
OVER	"no. 4"
UNDER	"no. 5"
"Chc buZ"	Buzzer
<input type="checkbox"/> Pressing [ENTER] sounds the built-in buzzer and displays "buSy" while sounding. * To return to the check item-selecting mode, press [ESC]. * If the buzzer has sounded continuously for 10 minutes, it returns to the check item-selecting mode automatically.	
"Chc EEP"	EEPROM
<input type="checkbox"/> Pressing [ENTER] checks the function of the EEPROM and displays "buSy" while checking. The results of the check will be displayed later. * The keys will not work while checking the EEPROM. * To return to the check item-selecting mode, press [ESC].	
Result of check	Display
Good condition	"PASS"
Something wrong	"Err"
"Chc bAt"	Lithium battery
<input type="checkbox"/> Pressing [ENTER] checks the function of the battery. The results of the check will be displayed later.	
Result of check	Display
Good condition	"PASS"
Something wrong	"Err"
"Chc Si"	Standard serial output
<input type="checkbox"/> Pressing [ENTER] tests the function of the standard serial output by sending 123<CR><LF>(ASCII code) at the baud rate set in the SiF-03 function setting. "send123" is displayed for one second and it returns to the check item-selecting mode. * To return to the check item-selecting mode, press [ESC].	
"Chc in"	Control input (Terminal #1 to #6)
Displays the status of the control input terminals, #1 to #6, on the control signal terminals, located inside the case. "□" at an ON terminal is displayed at the lower position, an OFF terminal at the up position. * To return to the check item-selecting mode, press [ESC].	
Example: Terminal # 1,3,4,5: ON, and #2, 6: OFF	
<p>The diagram shows a control panel with six terminals labeled #1 to #6. Above the terminals are five status indicators: SET POINT, TOTAL, OVER, ACCEPT, and UNDER. Each indicator has a small circle next to it. Terminals 1, 3, 4, and 5 have their indicator circles in the lower position, indicating they are ON. Terminals 2 and 6 have their indicator circles in the upper position, indicating they are OFF. Arrows point from the terminal numbers to their respective indicator circles. Labels 'OFF' and 'ON' are placed to the left of the indicator circles to indicate their positions. A label 'OFF' is also placed to the right of terminal #6.</p>	

Display	Check Item						
"Chc Out"	Control output (Terminal #10 to #19)						
Turns on a terminal #10 to #19 in this order and displays a relevant terminal-number as shown below. (This check is performed automatically.)							
* Ignore these displays, "J11 6", "J11 4", "J11 2". They are for factory use.							
* To return to the check item-selecting mode, press [ESC].							
Terminal #	Display						
10	"tb1-10 1"						
11	"tb1-11 2"						
14	"tb1-14 3"						
15	"tb1-15 4"						
18	"tb1-18 5"						
19	"tb1-19 6"						
"Chc rS"	RS-232C/422/485						
<input type="checkbox"/> Pressing [ENTER] sends 123<CR><LF>(ASCII code) at the condition configured in its function, rSF-03, rSF-04, rSF-05, or rSF-06 and checks if the same data is returned. An installed option name is displayed on the sub display. In case of OP-03 (RS-422/485), press [F] to see either "485" or "422" setting.							
* To return to the check item-selecting mode, press [ESC].							
<table border="1"> <thead> <tr> <th>Result of check</th> <th>Display</th> </tr> </thead> <tbody> <tr> <td>Good condition</td> <td>"PASS"</td> </tr> <tr> <td>Something wrong</td> <td>No change on display</td> </tr> </tbody> </table>		Result of check	Display	Good condition	"PASS"	Something wrong	No change on display
Result of check	Display						
Good condition	"PASS"						
Something wrong	No change on display						
"Chc An"	Analog output						
Apply a current in the range of 2mA to 22mA with [FUNC.] (Increase) and [F] (Decrease) and see if the current value is displayed.							
* To return to the check item-selecting mode, press [ESC].							

9-2 Clearing "Zero" and "Tare"

To clear the Zero and Tare stored in the memory, turn on the power while pressing [TARE].

9-3 Initialization

	You will lose all the setting data stored in the memory by initializing. The lost data can not be retrieved.
---	--

Initialization swaps all the data stored in the memory in the RAM and the EEPROM with the default data that factory has configured originally. There are 3 types of initialization depending on items to be initialized. The item marked with “√” in the table below will be initialized.

Initializing Item			Initialization Mode	
RAM Stores;	EEPROM Stores;		Mode name	Display in the initialization mode
Zero Tare Set point Total weight Total count	Function data	Calibration data		
√			RAM initialization	<code>"init rA"</code>
√	√		RAM & Function initialization	<code>"initFnc"</code>
√	√	√	All data initialization	<code>"initAll"</code>

Initialization procedures

First make sure that the calibration disable switch (inside the case) is set to the ON position. If not, initialization will not be performed.

Select the type of initialization and follow the procedure number to initialize.

* To return to the normal mode in the middle of initializing, press [ESC].

RAM initialization: <code>"init rA"</code>				
1	RAM & Function initialization: <code>"init Fnc"</code>			
	All data initialization: <code>"initALL"</code>			
	Enter the RAM initialization mode			
	<input type="checkbox"/> Turn the power on while pressing [SET POINT]. <code>"init rA"</code> is displayed.			
1	Enter the RAM & Function initialization mode			
	<input type="checkbox"/> Turn the power on while pressing [SET POINT]. <code>"init rA"</code> is displayed. <input type="checkbox"/> Press [F], <code>"init Fnc"</code> is displayed.			
1	Enter the All data initialization mode			
	<input type="checkbox"/> Press [CALF] while pressing [ENTER] in the normal mode. <input type="checkbox"/> Press [ENTER]. <input type="checkbox"/> Press [F], <code>"initALL"</code> is displayed.			
	Initialization			
2	2	2	<input type="checkbox"/> Press [ENTER], display blinks to warn against losing data. If not initialize <input type="checkbox"/> Press [ESC] to escape from the initialization mode without performing and return to the normal mode.	
			To initialize <input type="checkbox"/> Press [ENTER] for 3 seconds to initialize the data. It will initialize the data and returns to the normal mode.	

APPENDIX A: SPECIFICATIONS

Specifications

A/D Converter Block		
Input sensitivity	0.3 μ V/D or more	
Zero correction range	0 – 20mV (0 - 2mV/V)	
Load cell excitation	10 VDC \pm 5%, 120mA with remote sensing capability Up to four 350 Ω load cells can be connected	
Temperature coefficient	Zero point	\pm (0.2 μ +0.0008% of Dead Load)/ typical
	Sensitivity	\pm 0.0008%/ $^{\circ}$ C typical
Non-linearity	\pm 0.01% F.S.	
Input noise	\pm 0.3 μ Vp-p or less	
Maximum measurement voltage	32mV(3.2mV/V)	
A/D conversion method	Sigma-delta method	
A/D internal resolution	Approximately 1,000,000 max.	
Sampling speed	100times /second	
Maximum display resolution	10000D (D: minimum division)	
Digital Block		
Main Display	Element	<ul style="list-style-type: none"> • 7 digits, 7-segment, Character height:13mm • Fluorescent display tube • Display color: Cobalt blue, Status display in orange
	Item displayed	<ul style="list-style-type: none"> • Gross weight, net weight
Sub Display	Element	<ul style="list-style-type: none"> • Element: 8 digits, 7-segment, Character height: 7mm • Fluorescent display tube • Display color: Cobalt blue, Status display in orange
	Item displayed	<ul style="list-style-type: none"> • Tare, Final, Accumulated weight (Can be selected in the function setting.) • Calibration and function setting information in a setting mode
Status Display section	<ul style="list-style-type: none"> • 14 “ ” marks 	
LED	5 LEDs (SET POINT, TOTAL, OVER, ACCEPT, UNDER)	
Keys	Type A	[ZERO], [TARE], [NET/GROSS], [ON / OFF], [“7”/UNDER/ANF], [“8”/OVER/CALF], [“9”/PRESET TARE], [SET POINT], [“4”/OP.PRELIM/OUTF], [“5”/ZERO BAND/SIF], [“6”/FULL/RSF], [FUNC.], [“1” / FINAL/FncF], [“2” / FREE FALL/SQF], [“3”/PRELIM/INF], [F], [“0”/CODE], [+ / -], [ESC], [ENTER]
	Type B	[ZERO], [TARE], [NET/GROSS], [ON / OFF], [“7”/ANF], [“8”/CALF], [“9” /PRESET TARE], [SET POINT], [“4” / Lo / OUTF], [“5” / Lo-Lo / SIF], [“6” /ZERO BAND/RSF], [FUNC.], [“1”/Hi-Hi/FncF], [“2”/Hi /SQF], [“3”/Go/INF], [F], [“0”/CODE], [+ / -], [ESC], [ENTER]
Switches	<ul style="list-style-type: none"> • Main power switch • Calibration disable switch (used when required by law.) • Located inside the case. 	

Interfaces		
Control I/O	Input (CONTROL IN)	<ul style="list-style-type: none"> • 6 points (6 bits, 2 Commons) • Dry contact or open collector • Signal is insulated from an internal circuit by an optocoupler. • Terminal functions selectable by the function settings
	Output (CONTROL OUT)	<ul style="list-style-type: none"> • 6 points (2 bits, 1 Common x 3) • Relay contact output • AC current output available • Rating: 24 VDC, 0.5 A (Resistance load), 220 VAC, 0.5 A (Resistance load)
Standard serial output(C.LOOP OUT)	Output for connection to a peripheral device manufactured by A&D (0 to 20 mA current loop signal)	
Weighing Capabilities		
Zero point correcting capability (Zero)	<ul style="list-style-type: none"> • Clears the gross to zero in compliance with a command from the ZERO keys, Control I/O, etc. • Capable of enabling or disabling operations when unstable. • A battery backs up zero correction value. • Adjustable range: Can be freely set within 1 to 30 % of weighing capacity. 	
Zero tracking capability	<ul style="list-style-type: none"> • Detects gross zero point drift and performs zero correction automatically. • Tracking time: 0.0 to 5.0 (seconds) The range can be set freely. • Tracking width: 0.0 to 4.5 (D). The range can be set freely 	
Tare subtracting function	<ul style="list-style-type: none"> • Clears the net weight to zero in compliance with a command from the TARE key, Control I/O, etc. • Capable of enabling or disabling operations when unstable or negative weight. • The battery backs up the tare value. • Adjustable range: $gross \leq Weighing\ capacity$ 	
Preset tare subtracting function	<ul style="list-style-type: none"> • Sets/recalls presets tare for each code number. • Adjustable range: $0 < gross \leq Weighing\ capacity$ 	
Stability detecting capability	<ul style="list-style-type: none"> • When a weighed value fluctuation amount per sampling enters a set width within a set time, the stability mark is illuminated, judging it a stable condition. • Capable of confirming stability through Control Output. • Stability detection time: 0.1 to 5.0 (seconds). The range can be set freely. • Stability detection width: 0 to 9 (D). The range can be set freely 	
Digital filter function Integrating capability	<ul style="list-style-type: none"> • Two digital filters connected in series • Cutoff frequency range: 0.7 to 11 (Hz) 	
Accumulation capability	<ul style="list-style-type: none"> • Accumulates the net weight automatically or manually. • The battery backs up an accumulated weight and the number of accumulated weighing counts. • Accumulated weight range: 0 to 99999999 • Accumulated weighing times range: 0 to 99999999 	

General specifications				
Structure	<ul style="list-style-type: none"> • Anti explosion structure • Type: ExD BT5 (Inspection qualified number: "C13526") 			
Data backup	<ul style="list-style-type: none"> • Zero point correction value, tare value, set point, accumulated weight backup by a lithium battery (Approx. 10 years) • An alarm indicator lamp is turned on when the battery is running out. • Calibration data, and each function data stored into the non-volatile memory (EEPROM). (Up to 10,000 times) 			
Buzzer	Approximately 90dB at a place 1 meter away.			
Supply voltage	100 VAC +10%-15%, 50Hz 60Hz			
Power consumption	60 VA			
Fuse	1A, time-lag type fuse			
Operating temperature & humidity	-5 to +40°C, 45 to 85%RH (non-condensing)			
Storage temperature & humidity	-15 to 70°C, 45 ~ 85%RH (non-condensing)			
Weight (accessories not included)	Approximately 26kg			
Dimensions	300(W) X 380(H) X 199(D) mm See {Dimensions} in detail			
Options				
RS-422/485	OP-03	Either OP-03 or OP-04 can be installed. Not both in one unit.		
RS-232C	OP-04			
Analog output	OP-07			
Conduit fittings	OP-10	Type	Fitting cable diameter	Fitting connector diameter
		HPN21(R 8)	up to 8 mm beyond 6 mm	G 1/2 (PF 1/2)
	OP-11	HPN21(R10)	up to 10 mm beyond 8 mm	
	OP-12	HPN21(R12)	up to 12 mm beyond 10 mm	
	OP-13	HPN22(R14)	up to 14 mm beyond 12 mm	G 3/4 (PF 3/4)
OP-14	HPN22(R16)	up to 16 mm beyond 14 mm		
Stand	OP-20			
Accessories				
<ul style="list-style-type: none"> • Hexagonal wrench to open/close the case X 1 • Hexagonal wrench to affix cables to conduit fittings X 1 • Instruction manual (this book) X 1 				

Dimensions: Indicator

(Unit: mm)

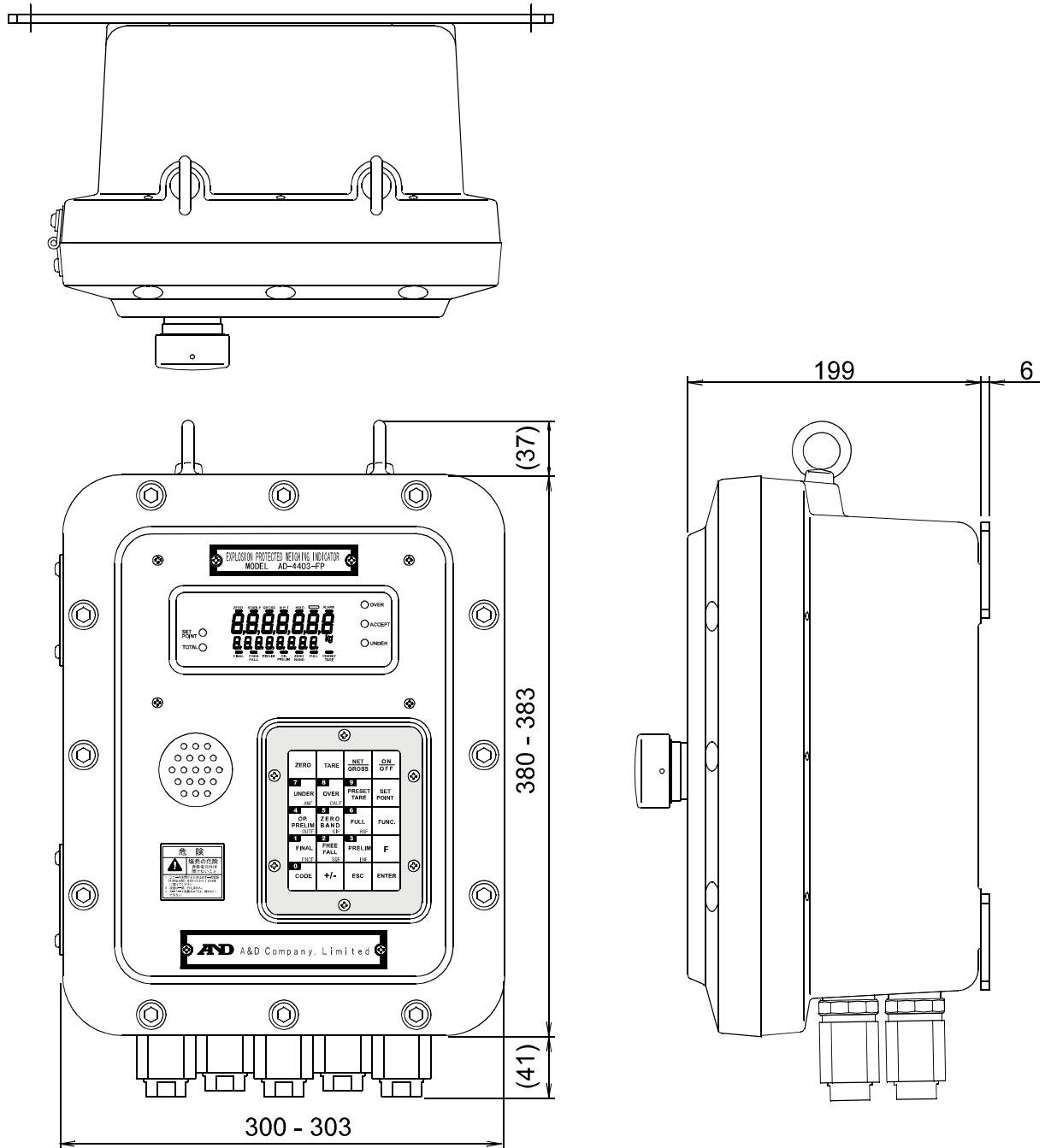

* Picture above is of type A model with conduit fitting options (OP-10-14) installed.

Dimensions: OP-20 Stand

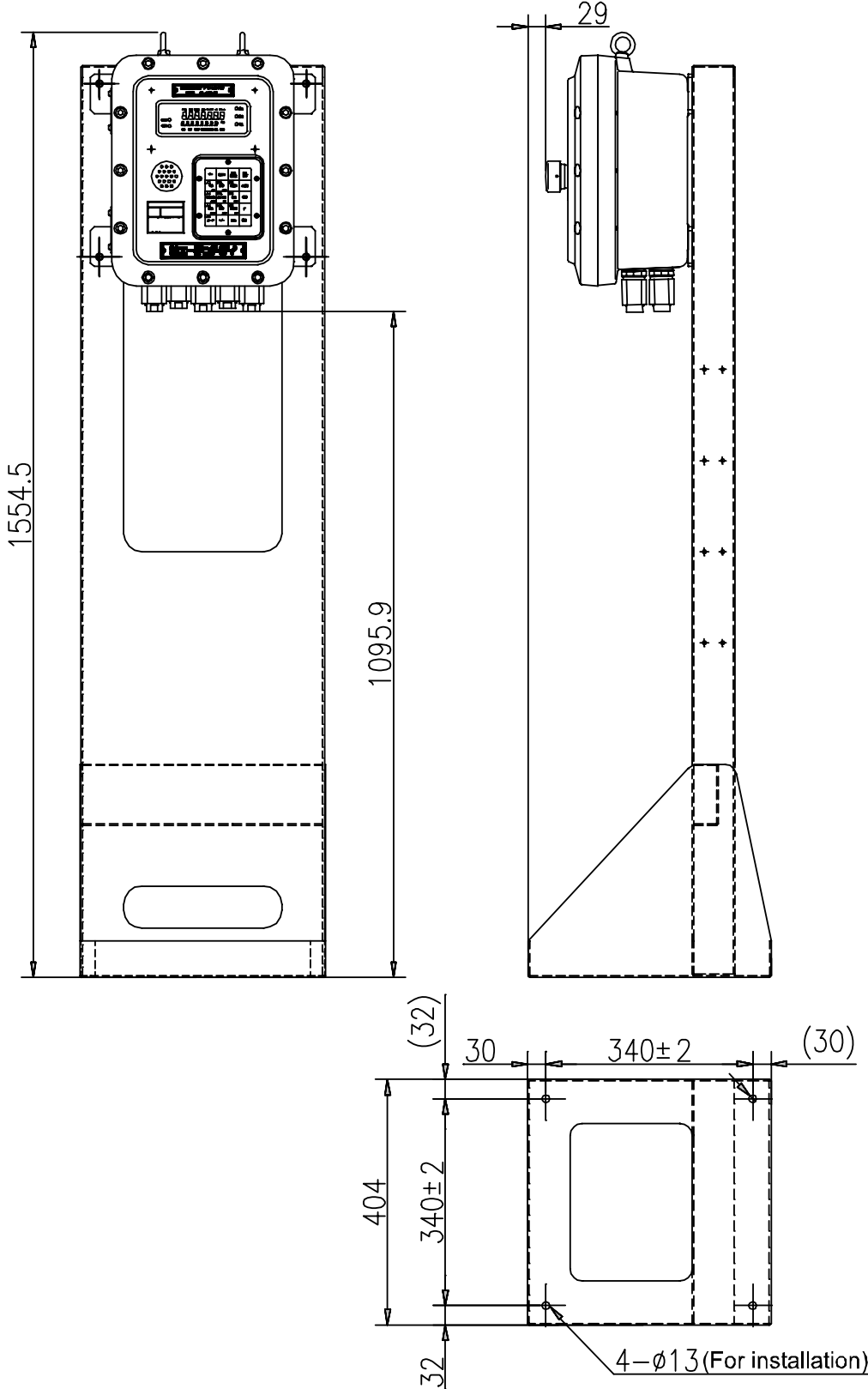

Mounting Dimensions

(Unit: mm)

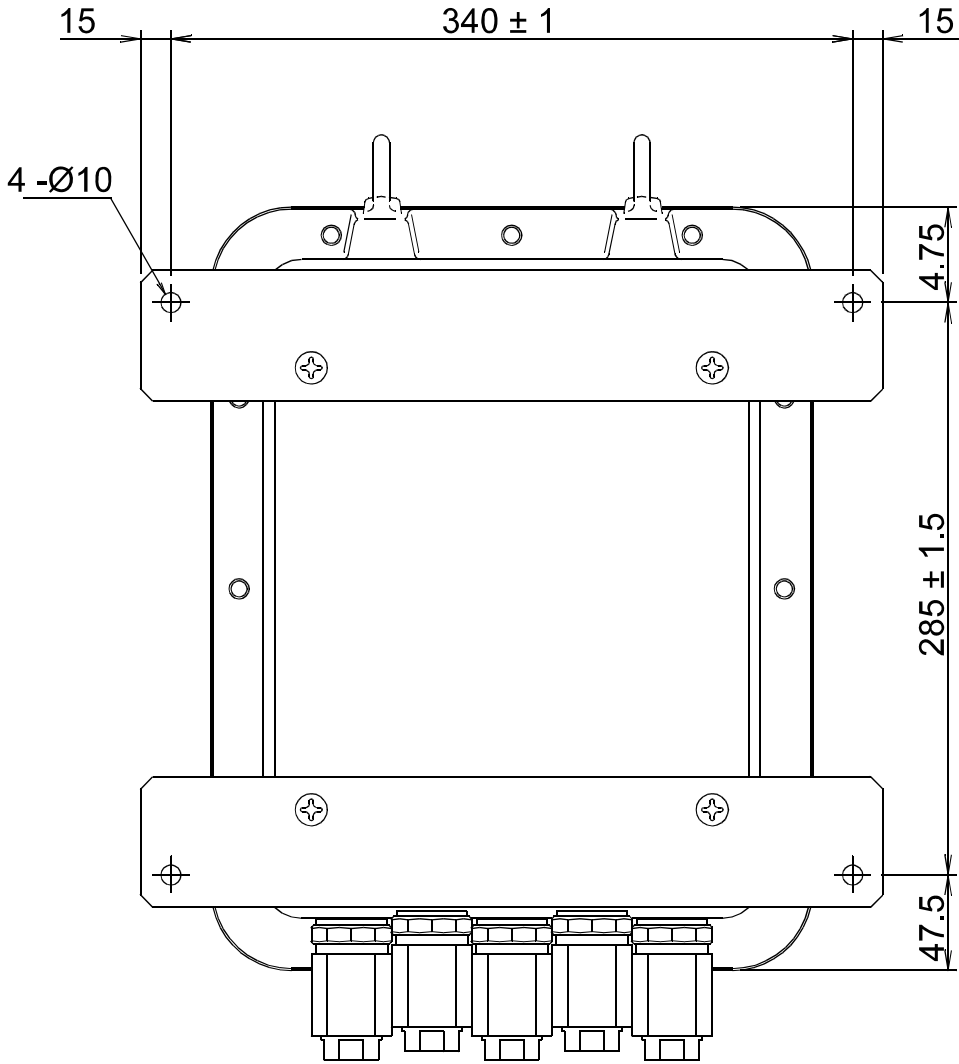

* Picture above is of type A model with conduit fitting options (OP-10-14) installed.

[Blank page]

APPENDIX B: ERROR CODES

Error code	Causes	Solutions
"C Err 0"	The minimum graduation is other than 1, 2, 5, 10, 20, and 50.	Confirm setting of the minimum graduation, CALF-03.
"C Err 1"	Resolution (weighing capacity divided by minimum graduation) is more than 16000.	Confirm the relations between the weighing capacity (CALF-04), and minimum division (CALF-03).
"C Err 2"	The voltage of the zero calibration point is overloaded in the positive direction.	Confirm the rating and connection of the load cell and see if the load cell is damaged. When the load cell is connected properly and is not defective, the load cell output can be corrected by attaching a resistor as shown below, {Load cell output compensation}. When it is likely that the load cell or A/D converter is defective, use the check mode in {9-1. System check—"Chc Ad"} to verify the problem.
"C Err 3"	The voltage of the zero calibrated point is overloaded in the negative direction.	
"C Err 4"	The calibration weight is more than the weighing capacity.	Calibrate with proper calibration weights.
"C Err 5"	The calibration weight is less than the minimum division.	
"C Err 6"	Sensitivity of the load cell is insufficient.	When "C Err 6" or "C Err8" is displayed after CALF-03 (Minimum division setting) and CALF-04 (Capacity setting) have been set, try to do the following settings for solution. <ul style="list-style-type: none"> • Reset CALF-03 (minimum division). • Reset CALF-04 (capacity). • Set CALF-20 (Span input voltage) to "3.200000 ". • Set CALF-21 (Weight against Span input voltage) to the capacity weight.
"C Err 8"	The output voltage of the load cell is too high with the span capacity loaded	
"C Err 9"	Gravity acceleration rate setting is not correct. (out of the range).	See {APPENDIX D: Gravity acceleration map} and set the value again.
"C Err 7"	The voltage of the span calibration point is negative with respect to the zero point.	Confirm the connection of the load cell.
"ERR St"	Failed to zero when the power was turned on.	Confirm the connection of the load cell and around the load cell.
"Err PZr"	Zero was out of the zero valid range when the power was turned on.	

Load cell output compensation

Attach a resistor to a place as shown in the picture below to compensate the load cell output. Use a resistor with as high resistance and low temperature coefficient as possible.

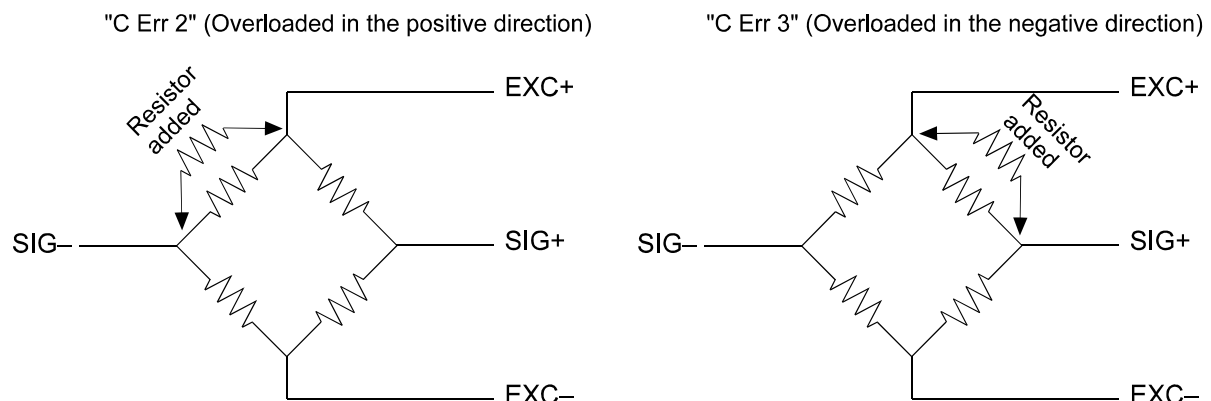

[Blank page]

APPENDIX C: FUNCTION LIST

Section related: {5. Function settings}

FncF—Basic Functions

Function #	Function name	Default																											
FncF -01	key Operation	0																											
0	Not disabled																												
1	Disable																												
	<table border="1"> <thead> <tr> <th>Status display (lower)</th> <th>0</th> <th>0</th> <th>0</th> <th>0</th> <th>0</th> <th>0</th> <th>0</th> <th>0</th> </tr> </thead> <tbody> <tr> <td></td> <td>↑</td> <td>↑</td> <td>↑</td> <td>↑</td> <td>↑</td> <td>↑</td> <td>↑</td> <td>↑</td> </tr> <tr> <th>Key</th> <td>[+/-]</td> <td>[ENTER]</td> <td>[FUNC.]</td> <td>[SET POINT]</td> <td>[ON/OFF]</td> <td>[NET/GROSS]</td> <td>[TARE]</td> <td>[ZERO]</td> </tr> </tbody> </table>	Status display (lower)	0	0	0	0	0	0	0	0		↑	↑	↑	↑	↑	↑	↑	↑	Key	[+/-]	[ENTER]	[FUNC.]	[SET POINT]	[ON/OFF]	[NET/GROSS]	[TARE]	[ZERO]	
Status display (lower)	0	0	0	0	0	0	0	0																					
	↑	↑	↑	↑	↑	↑	↑	↑																					
Key	[+/-]	[ENTER]	[FUNC.]	[SET POINT]	[ON/OFF]	[NET/GROSS]	[TARE]	[ZERO]																					
<input type="checkbox"/> Press a key to be disabled, then press [F] to disable. When disabled, a relevant digit becomes "1" (Disabled).																													
<p>When [FUNC.] is disabled To perform function settings, press [FUNC.] and [ESC] at the same time. (Generally only [FUNC.] has to be pressed for the function settings, however [FUNC.] has been disabled. Therefore special key operation should be made.)</p>																													
FncF-02	[F] key function	0																											
0	No function																												
1	"Manual print" command																												
2	Hold																												
3	Batch start	Only effective in the weighing in the built-in automatic program																											
4	Emergency stop																												
5	Discharge start																												
6	Clear Zero																												
7	Clear Tare																												
8	Clear total accumulated weight and accumulated data of the code now in use.																												
9	Automatic free fall command																												
10	Accumulation command																												
11	Selection of weighing unit.																												
FncF-03	Display update rate																												
1	20 times /second																												
2	10 times /second																												
3	5 times /second																												

Function #	Function name	Range	Default
FncF-04	Sub display		0
0	None		
1	Gross weight		
2	Net weight		
3	Tare weight , Preset tare weight		
4	Final		
5	Total accumulated weight		
6	Total accumulated count		
FncF-05	<input type="checkbox"/> display		0
0	None		
1	"Discharging" (Only effective in normal batching in the built-in automatic program)		
2	"Zero tracking"		
3	"Weighing"		
4	"Weighing error"		
5	Input acknowledgement		
6	"Zero error"		
7	"Accumulation over"		
8	"Low battery"		
9	"Converting weighing unit"		
FncF-06	Digital filter	0 - 79	48
0	None	<p>The digital filter is designed to suppress dispersion of a load cell output signal. Two of them are connected in series as shown below.</p> <div style="text-align: center;"> <pre> graph LR ADC["A/D converter (fc=10Hz)"] --> DF1["Digital filter 1 10¹ digit"] DF1 --> DF2["Digital filter 2 10⁰ digit"] </pre> </div>	
1	11.0Hz		
2	8.0Hz		
3	5.6Hz		
4	4.0Hz		
5	2.8Hz		
6	2.0Hz		
7	1.4Hz		
8	1.0Hz		
9	0.7Hz		
<p>Low frequency components that cannot be covered only by setting of the digital filters can be dealt with by equivalently lowering the cutoff frequency of the digital filters at FNCF-07.</p>			
FncF-07	Sampling frequency dividing ratio	1 - 10	1
<p>Lower the cutoff frequency of the digital filters equivalently by reducing the specified sampling times to one.</p>			
FncF-08	Hold operation		1
1	Normal hold	During peak hold, the positive peak of the weight is held.	
2	Peak hold		
FncF-09	Comparison stop at hold		0
0	No	In case of weighing in the built-in automatic program mode, do not set "1" because the weighing sequence stops when comparison stops.	
1	Yes		

Function #		Function name	Default
FncF-10		Automatic return to the normal mode after indicating set point data	1
0	Disable	When no operation from keys for more than 10 seconds, it returns to the normal mode.	
1	Not disabled		
FncF-11		Preset tare weight by code	1
0	Disable	Preset tare without code number can be recalled in spite of the setting of "0".	
1	Not disabled (without tare-clear)	When there is no tare data to be recalled, previous tare weight will be used.	
2	Not disabled (with tare-clear)	When there is no tare data to be recalled, it clears the tare data.	
FncF-12		Recalling set point data by code	1
0	Disable		
1	Not disabled		
FncF-13		Setting set point code by code	1
0	Disable		
1	Not disabled		
FncF-14		Set point code NOT to be recalled by code	0
0	None		
1	Zero band		
2	Full		
3	Free fall		
4	Zero band, Full		
5	Zero band, Free fall		
6	Full, Free fall		
7	Zero band, Full, Free fall		
FncF-15		Continuous command of accumulation / manual print	0
0	Not disabled	With this function disabled, command is accepted only once when the net weight exceeds zero band value. After that, command will not be accepted unless load on the scale is removed. This function is to avoid double accumulation or printing for the same data.	
1	Disable on accumulation		
2	Disable on manual print		
3	Disable on both accumulation and manual print		

Sq F—Weighing Sequence Functions

The SqF functions are available only for the mode specified in the note column and each mode name is described as shown below. Not specified functions are available for all the weighing sequences.

Auto: Built-in automatic program mode

Batch: Batch-weighing mode

Loss: Loss-in-weight mode

Nozzle: Nozzle controlled weighing mode

Note	Function #	Function name	Range	Default
	SqF-01	Selection of comparison weight		1
	1	Internal count		
	2	Display count		
	Sq F-02	Automatic accumulation		0
	0	No Automatic accumulation		
	1	Accumulates only acceptable		
	2	Accumulates all values		
	Sq F-03	Automatic free fall compensation		0
Batch	0	No automatic free fall compensation		
	1	Moving average of last four times		
Batch	Sq F-04	Automatic free fall effective width	0 - 9999999	0
	Automatic free fall compensation is made if the measured weight is within the final +/- automatic free fall effective width.			
Auto	Sq F-05	Unstable Dribble Flow Time	0.0 - 25.5 (sec.)	3.0
	If Flow-time is shorter than the setting, the preset Free Fall is applied to the weighing instead of the Auto-Free-Fall compensation.			
Auto	Sq F-06	Overlimit/ underlimit operation		2
	1	Customer programmed control mode		
	2	Synchronized with Batch Finish Output		
Auto	Sq F-07	Stability at judgment		1
	0	Not required		
	1	Required		
Auto	Sq F-08	Maximum number of supplementary flow times	0 – 255 (times)	0
	This is the number of how many times supplementary flow is done.			
Auto	Sq F-09	Batch start wait timer	0.0 - 25.5 (sec.)	0.0
Auto	Sq F-10	Full-flow comparator inhibitor timer	0.0 - 25.5 (sec.)	0.0
Auto	Sq F-11	Medium-flow comparator inhibitor timer	0.0 - 25.5 (sec.)	0.0
Auto	Sq F-12	Dribble-flow comparator inhibitor timer	0.0 - 25.5 (sec.)	0.0
Auto	Sq F-13	Judgment wait timer	0.1 - 25.5 (sec.)	0.1

Note	Function #	Function name	Range	Default
Auto	Sq F-14	Batch Finish output width	0.0 - 25.5 (sec.)	0.0
Auto	Sq F-15	Batch monitoring timer	0 – 255 (sec.)	0
Auto	Sq F-16	Supplementary flow open timer	0.01 - 2.55 (sec.)	0.10
Auto	Sq F-17	Supplementary flow close timer	0.1 - 25.5 (sec.)	0.1
Auto	Sq F-18	Discharge start wait timer	0.0 - 25.5 (sec.)	0.0
Auto	Sq F-19	Discharge valve close wait timer	0.1 - 25.5 (sec.)	0.1
Auto	Sq F-20	Discharging time monitor timer	0 - 255 (sec.)	0
Loss	Sq F-21		Add the final to zero band setting	0
	0	Does not add the final		
	1	Adds the final		
Loss	Sq F-22		Add the final to full setting	0
	0	Does not add the final		
	1	Adds the final		
	Sq F-23		Batch start function key	0
	0	Disable		
	1	[ESC]		
	2	[+/-]		
	Sq F-24		Emergency stop function key	0
	0	Disable		
	1	[ESC]		
	2	[+/-]		
	Sq F-25		Discharge start function key	0
	0	Disable		
	1	[ESC]		
	2	[+/-]		
Nozzle	Sq F-26		Automatic Tare at batch start	0
	0	Disable	It tares automatically when detects the “zero band” signal at a weighing completion. (ready to re-start)	
	1	Not disabled		

Note	Function #	Function name	Range	Default
	Sq F-27	Buzzer		0
	0	Disable	The built-in buzzer sounds synchronized with the selected signal for the period of time Sq F-28 has determined. If the buzzer sounds more than 10 minutes, it will automatically stop sounding to avoid damage to the buzzer. * (Type B)	
	1	Full-flow (Go)		
	2	Medium-flow (Lo)		
	3	Dribble-flow (Lo-Lo)		
	4	Over limit (Hi)		
	5	Acceptable weight		
	6	Under limit (Hi-Hi)		
	7	Zero band		
	8	Batch finish		
	9	Weighing sequence running		
	10	Full		
	11	Stable		
	12	Over limit/under limit		
	13	Weighing sequence error		
	Sq F-28	Buzzer sounding time	0.0 – 25.5 (sec.)	3.0
The "0.0" setting sounds the buzzer for 10 minutes.				
	Sq F-29	Saving automatic free fall compensation data		0
	0	Disable		
	1	Not disabled		

In F—Control Input Functions

Function #		Function name	Default
in F-01 - 06		Control Input; Capability of pins #1 to #9 of the control signal terminals inside the case.	in F-01: 1 in F-02: 2 in F-03: 3 in F-04: 4 in F-05: 5 in F-06: 6
0	No capability	Edge-input	
1	Zero		
2	Tare		
3	Batch start		
4	Emergency stop	Level-input	
5	Discharge start	Edge-input	
6	Key enable	Level-input	
7	Automatic free fall command	Edge-input	
8	Tare clear		
9	Accumulation command		
10	Cancel previous accumulation		
11	Total accumulated weight clear		
12	Clear both total accumulated weight and accumulated weight of the code used now.		
13	Clear all the accumulated weight by code.		
14	Hold	Level-input	
15	Manual print command	Edge-input	
16	Weighing unit select	Edge-input	

outF—Control Output Functions

Function #		Function name	Range
outF-01 - 06		Control output; Capability of pins #10, 11, 14, 15, 18, and 19 of the control signal terminals inside the case.	outF-01: 1 outF-02: 2 outF-03: 3 outF-04: 4 outF-05: 5 outF-06: 6
0	No capability		
1	Zero band		
2	Under limit (Hi-Hi)	*(Type B)	
3	Over limit (Hi)		
4	Full-flow (Go)		
5	Medium-flow (Lo)		
6	Dribble-flow (Lo-Lo)		
7	Discharge gate open		
8	Batch finish		
9	Acceptable weight		
10	Full		
11	Nozzle down		
12	Stable		
13	Online		
14	Weighing sequence running		
15	Weighing sequence error		
16	Input acknowledge		
17	Zero range error		
18	Weighing capacity overflow		
19	Low battery		
20	Accumulated weight/count overflow		
21	Weighing unit converting		

SiF—Standard Serial Output Functions

Function #	Function name	Default	
SiF-01		Output data	1
1	Displayed weight		
2	Gross weight		
3	Net weight		
4	Tare		
5	Gross weight/net weight/tare		
6	Accumulated weight		
7	Accumulated count		
8	Accumulated weight/accumulated count		
SiF-02		Data transmitting mode	1
1	Stream		
2	Auto print		
3	Manual print		
4	Accumulation timing print		
SiF-03		Baud rate (bps)	2
1	600 bps		
2	2400 bps		
SiF-04		Code number output	0
0	None		
1	Output data with its code number		

rSF—OP-03:RS-422/485/ OP-04:RS-232C Functions

Function #	Function name	Default
rSF-01 Output data		1
1	Displayed weight	Data format: form A (A&D standard) See {8-6:Data Transmitting Format}.
2	Gross weight	
3	Net weight	
4	Tare	
5	Gross weight/net weight/tare	
6	Accumulated weight	
7	Accumulated count	Data format: form C (accumulation data format) See {8-6:Data Transmitting Format}.
8	Accumulated weight/accumulated count	
rSF -02 Data transmitting mode		1
1	Stream	
2	Auto print	
3	manual print	
4	Accumulation timing print	
5	Command	Set to 9600 bps or less.
6	Set point data + gross value (Output per sampling)	Data format: form H (Weighing Condition Read-Out Format) See {8-6:data format}.
7	Set point data net value (Output per sampling)	
rSF -03 Baud rate bps		5
1	600 bps	
2	1200 bps	
3	2400 bps	
4	4800 bps	
5	9600 bps	
6	19200 bps	
rSF -04 Parity		2
0	None	
1	Odd	
2	Even	
rSF -05 Character bit length		7
7	7 bits	
8	8 bits	
rSF -06 Stop bit length		1
1	1 bits	
2	2 bits	
rSF -07 Terminator		2
1	<CR>	
2	<CR><LF>	
rSF -08 RS-422/485 switching		1
1	RS-422	This setting is invalid when the RS-232C is used.
2	RS-485	
rSF -09 Address number		0
0	No address capability	Set to "0" in case of the RS-232C.
01 - 99	With address capability	
rSF -10 Code number output		0
0	None	
1	Outputs data with its code number.	

AnF—Analog Output Functions

Function #	Function name	Range	Default
AnF-01	Output data		1
1	Displayed weight		
2	Gross weight		
3	Net weight		
AnF-02	Weight at 4 mA output	-999999 - 9999999	0
AnF-03	Weight at 20 mA output	-999999 - 9999999	10000

CALF—Calibration Functions

ST: In case of the ST series, do not change the settings. If changed, weighing will not be performed properly.

Function #	Function name	Range	Default
CALF-01 ST	Weighing unit		2
0	None		
1	g		
2	kg		
3	t		
CALF-02 ST	Decimal point position		0
0	None	1 2 3 4 5	
1	10 ¹	1 2 3 4.5	
2	10 ²	1 2 3.4 5	
3	10 ³	1 2.3 4 5	
4	10 ⁴	1.2 3 4 5	
CALF-03 ST	Minimum division	1, 2, 5, 10, 20, 50 (D)	1
Minimum division (D) for the weight. Input 1, 2, 5, 10, 20, or 50(decimal point ignored).			
CALF-04 ST	Capacity	0 – 800000 Decimal point ignored	10000
Capacity of the weighing. Weighing is allowed up to this setting + 9D(9 divisions). A weight beyond this limit is an overflow and not displayed.			
CALF-05	Zero range	0 - 30	2
A range of accepting "zero" from the [ZERO] key or Control I/O. Represented in terms of percent (%) with respect to the weighing capacity, centering to the zero calibrated point in calibration. If this is set to 2, "zero" can be accepted within a range of the zero calibrated point +/- 2 %.			

Function #	Function name	Range	Default
CALF-06	Zero Tracking Time	0.0 - 5.0 (sec.)	0.0
CALF-07	Zero Tracking Width	0 - 9 (1/2D)	0

Zero tracking compensation function will automatically bring the display back to zero when there are small deviations. This function is set in combination with CALF-06 and CALF-07.

* Zero tracking is not performed with CALF-06=0.

* Its least input increment is 1/2D. (The width for setting of 1 is equivalent to 1/2 of the minimum graduation)

Example: CALF-06 = 1.0 (1sec.) Valid Zero Track Range
CALF-07 = 8 (4D) Invalid Zero Track Range

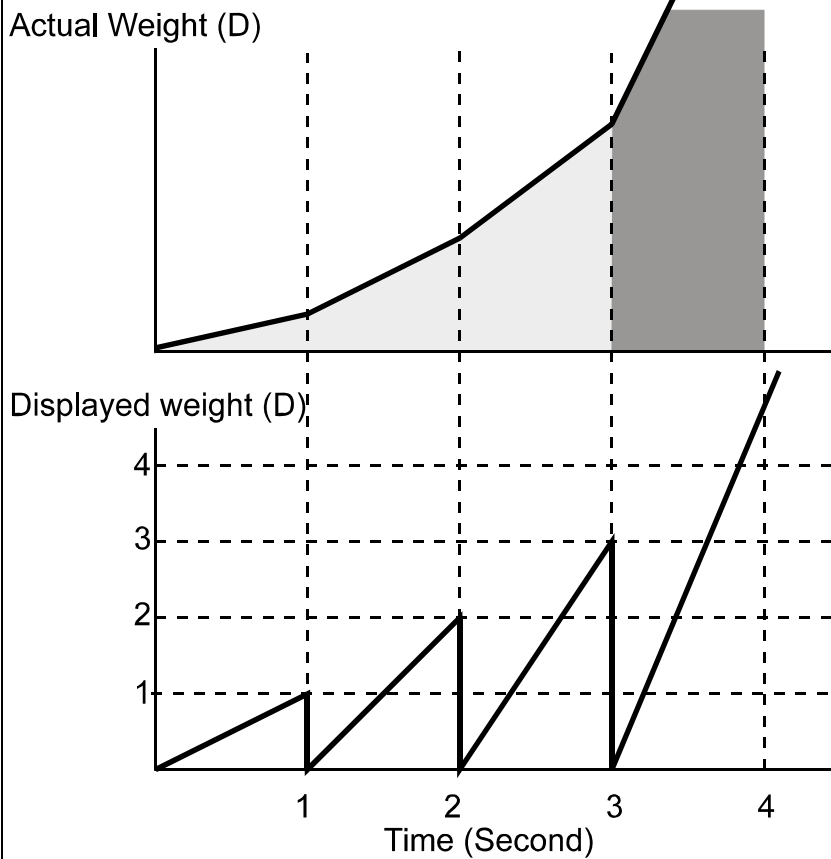

Function #	Function name	Range	Default
CALF-08	Motion detection time	0.0 - 5.0 (sec.)	1.0
CALF-09	Motion detection width	0 - 9 (1D)	2

These settings modify the "Stable" condition by the counts per time of non-movement before the indicator recognizes the stable condition. The fewer counts per longer time are more likely to recognize the stable condition and vice versa.

- * Motion detection function is not performed with CALF-08=0.
- * "D" is minimum division.

Example: CALF-08 = 2 (Stability Detection Time: 2sec.) Stability Detection Range
 CALF-09=1 = 1 (Stability Detection Width: 1D) Stable Range

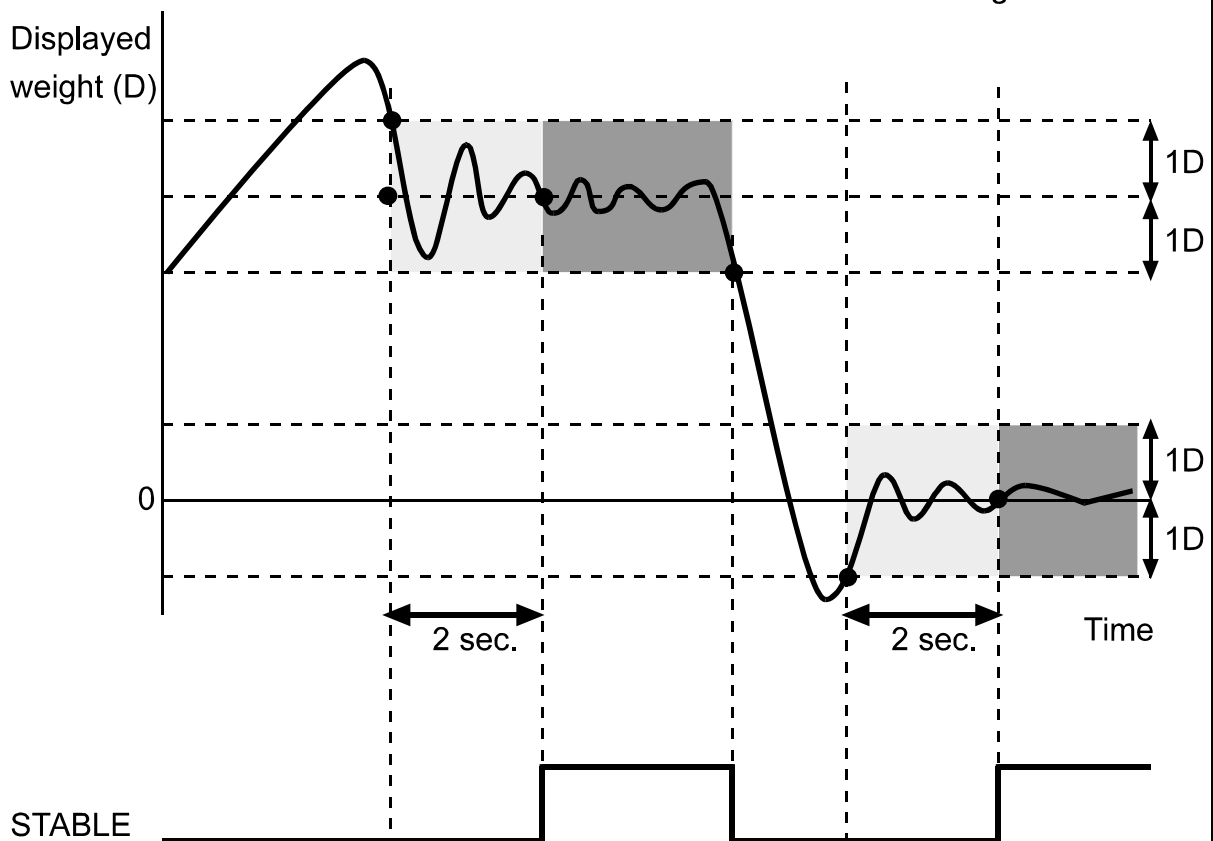

CALF-10	Tare and Zero compensation at Unstable reading	1
0	Not accepted	
1	Accepted	
CALF-11	Tare at negative gross weight	1
0	Not accepted	
1	Accepted	
CALF-12	Standard Serial Output: Output When Weight Is Overflowing or Unstable.	1
0	Not output	
1	Output	
CALF-13	RS-232C/-422/-485: Output When Weight Is Overflowing or Unstable.	1
0	Not output	
1	Output	

Function #	Function name	Range	Default
CALF-14		Weighing mode	3
1	Normal batching (Customer Programmed Control Mode)	See {6. Weighing} in detail.	
2	Loss-in-weight (Customer Programmed control Mode)		
3	Normal batching (Built-in automatic program mode)		
4	Loss-in-weigh (Built-in automatic program mode)		
5	Nozzle Controlled Weighing Mode (Built-in automatic program mode)		
6	Check weighing 1		
7	Check weighing 2		
8	Check weighing 3		
9	Check weighing 4		
CALF-15		Preset tare	1
0	Disable	When disabled, preset tare can not be set nor recalled.	
1	Not disabled		
CALF-16		Distinguish between preset tare and tare	0
0	None (same)	When "1" is set (distinguished), " " illuminates on the lower status display section when "preset tare" is used and header of serial output becomes "PT" (preset tare) and "T" (tare) * Pressing [PRESET TARE] always shows preset value regardless of this setting.	
1	Distinguished		
CALF-17		Serial interface; Print preset tare value with net weight (Si F-01=3, rsF-01=3)	0
0	Not printed		
1	Print		
CALF-18		Push-zero and tare-clear function when powered on and when the display is turned on.	0
0	Both push-zero and tare-clear are disabled.	Push-zero is performed at stable reading. If unstable for 10 seconds or longer, "Err St" (Error message) appears on the display. When reading is out of the range of push-zero, "Err PZr" is displayed on the display. (Press [ESC] to return to the normal mode.)	
1	Only push-zero is available.		
2	Only tare-clear is available.		
3	Both push-zero and tare-clear are available.		

ST : In case of the ST series, do not change the settings. If changed, weighing will not be performed properly.

Function #	Function name	Range	Default
CALF-19 ST	Zero Input Voltage	0.000000 - 2.200000 (mV/V)	0.000000

Input Voltage (mV/V) from the Load Cell at "Zero", which is determined in "Zero Calibration" with weights.—Actual load calibration

CALF-20 ST	Span Input Voltage (Capacity to zero)	0.000000 - 3.2000000 (mV/V)	3.200000
--------------------------	--	------------------------------------	-----------------

Input Voltage (mV/V) from the Load Cell at "Span", which means the difference between Capacity and Zero. The voltage is determined in "Span Calibration" with weights—Actual load calibration.

CALF 21 ST	Weight against Span Input Voltage	0 – 800000 (Decimal point ignored)	16000
--------------------------	--	---	--------------

When "Digital-Calibration", calibration not using weights, is performed, CALF-19 and CALF-20 as well as CALF-21 also have to be done. Refer to the following.

- * This setting will be changed to capacity (CAL-04) if actual load calibration is done.
- * For future load cell replacement, keep a record of the CALF-19, CALF-20, and CALF-21 settings. (Use {APPENDIX F: User's setting record}.)
- * Accuracy at replacement: 1/500 approximately
- * Revising CALF-19, CALF-20, and CALF-21 settings can perform "Zero calibration" and "Span calibration".
- * Accuracy of digital span calibration: 1/1000approximately
- * Accuracy of the output from the load cell depends on the calibration conditions.
- * Actual load calibration is highly recommended for a better accuracy. Perform digital span calibration only when calibration with weights can not be done.

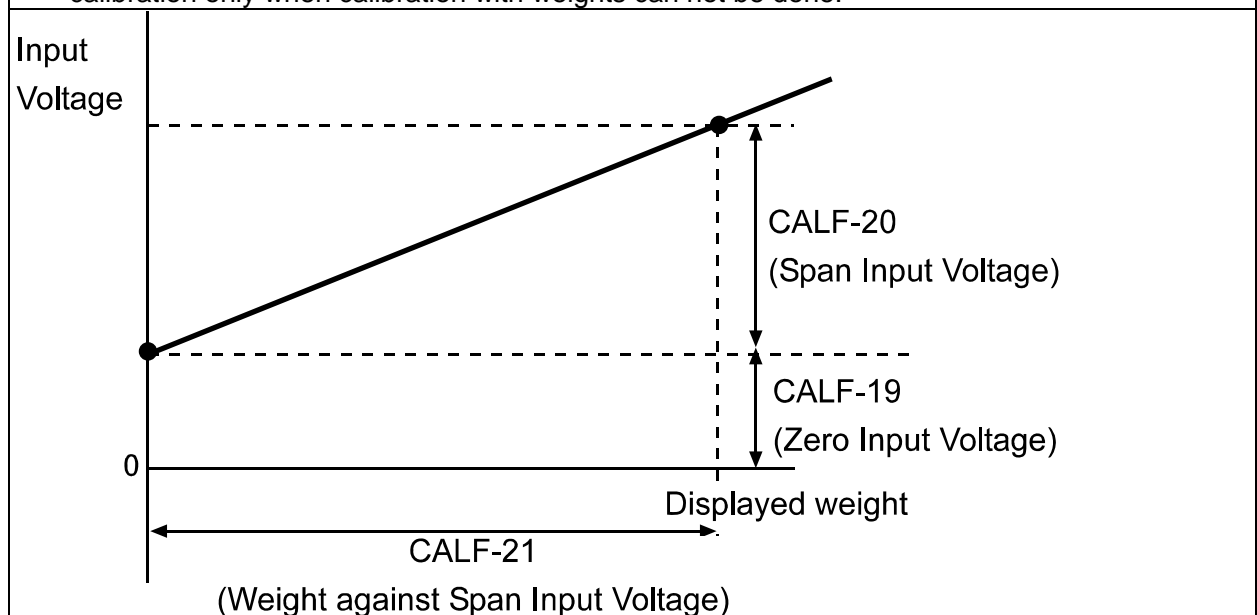

APPENDIX D: GRAVITY ACCELERATION MAP

Amsterdam	9.813 m/s ²	Manila	9.784 m/s ²
Athens	9.800 m/s ²	Melbourne	9.800 m/s ²
Auckland NZ	9.799 m/s ²	Mexico	9.779 m/s ²
Bangkok	9.783 m/s ²	Milan	9.806 m/s ²
Birmingham	9.813 m/s ²	New York	9.802 m/s ²
Brussels	9.811 m/s ²	Oslo	9.819 m/s ²
Buenos Aires	9.797 m/s ²	Ottawa	9.806 m/s ²
Calcutta	9.788 m/s ²	Paris	9.809 m/s ²
Chicago	9.803 m/s ²	Rio de Janeiro	9.788 m/s ²
Copenhagen	9.815 m/s ²	Rome	9.803 m/s ²
Cyprus	9.797 m/s ²	San Francisco	9.800 m/s ²
Djakarta	9.781 m/s ²	Singapore	9.781 m/s ²
Frankfurt	9.810 m/s ²	Stockholm	9.818 m/s ²
Glasgow	9.816 m/s ²	Sydney	9.797 m/s ²
Havana	9.788 m/s ²	Taiwan	9.788 m/s ²
Helsinki	9.819 m/s ²	Taipei	9.790 m/s ²
Kuwait	9.793 m/s ²	Tokyo	9.798 m/s ²
Lisbon	9.801 m/s ²	Vancouver, BC	9.809 m/s ²
London (Greenwich)	9.812 m/s ²	Washington DC	9.801 m/s ²
Los Angeles	9.796 m/s ²	Wellington NZ	9.803 m/s ²
Madrid	9.800 m/s ²	Zurich	9.807 m/s ²

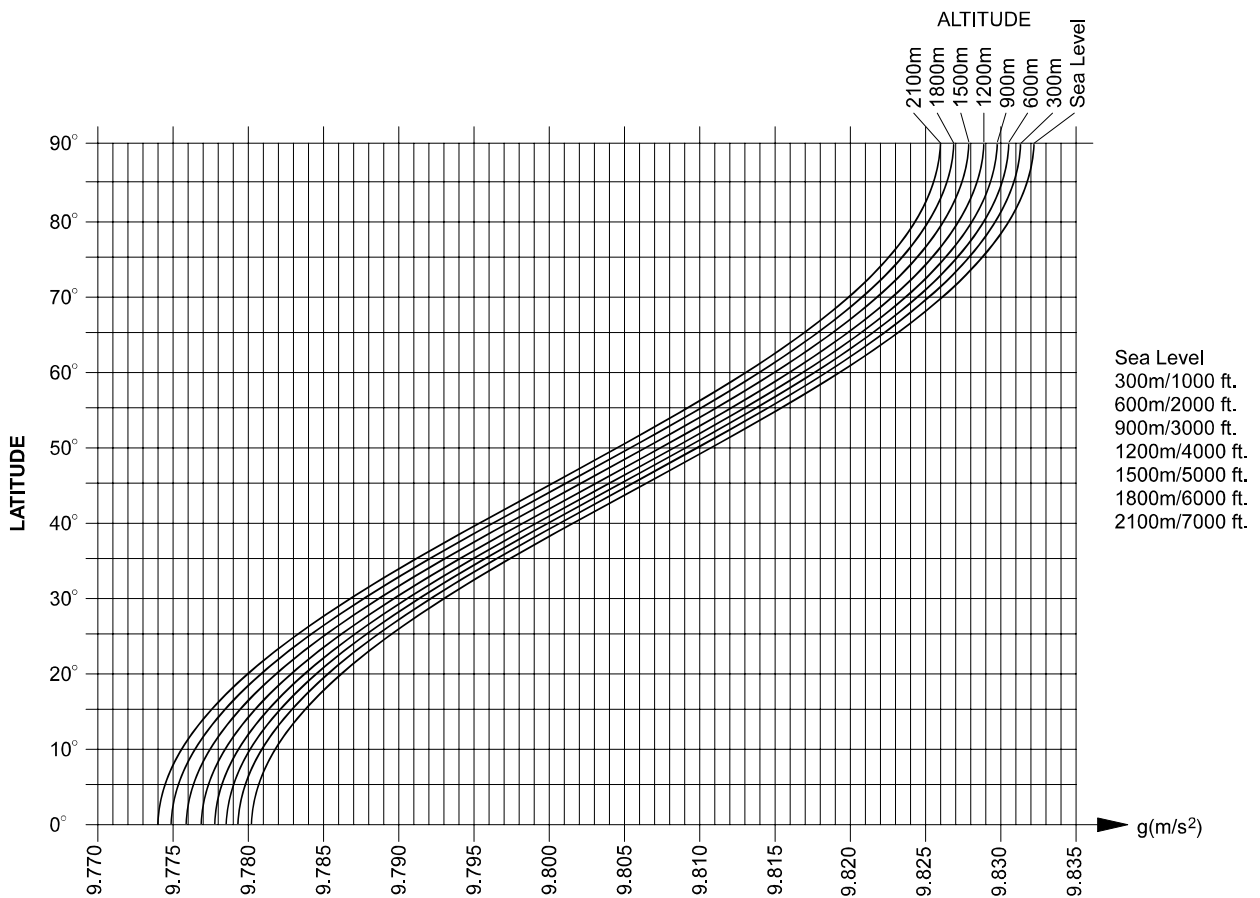
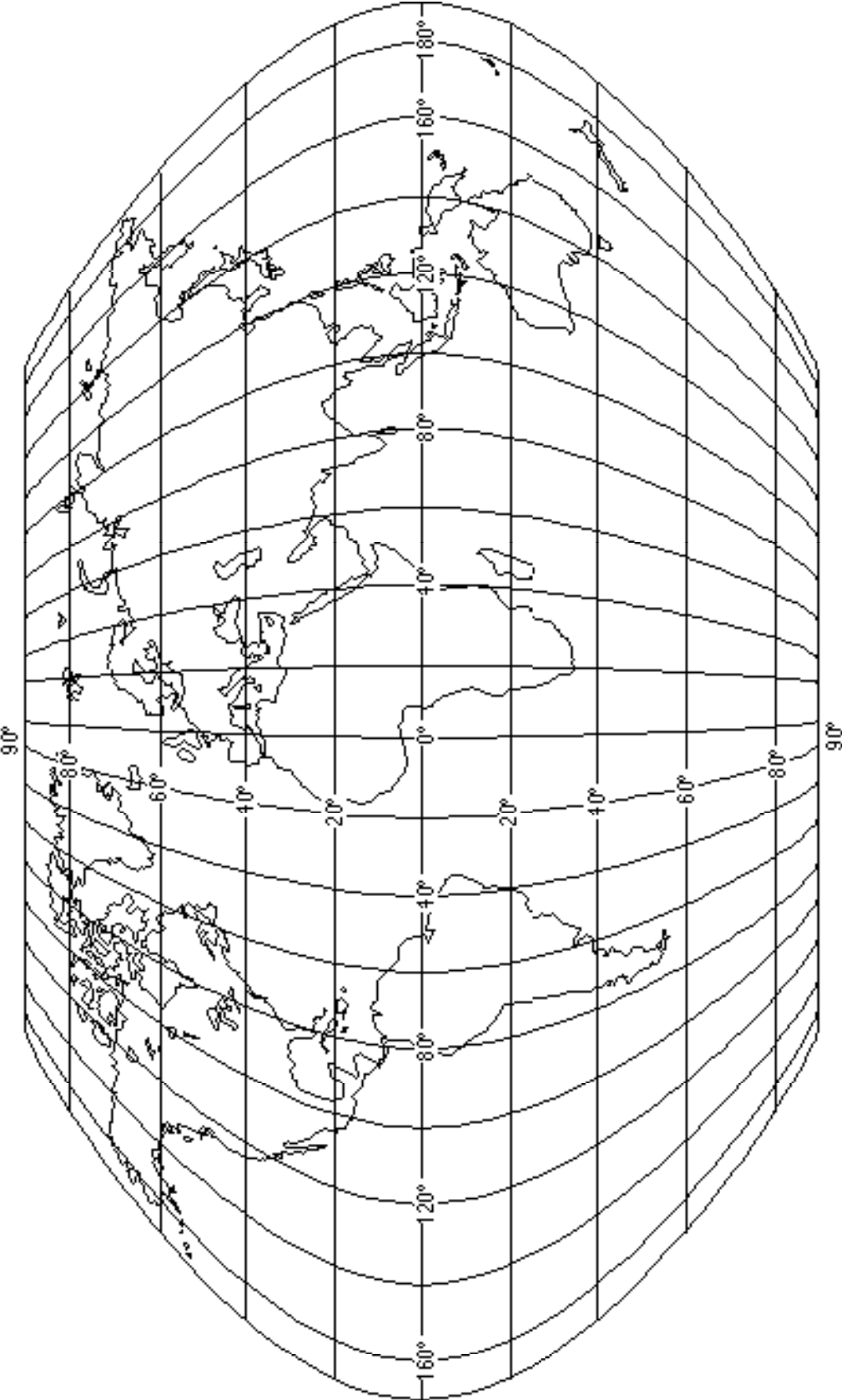

Fig Apx-D-02 Gravity map.WMF



APPENDIX E: DATA OUTPUT EXAMPLES

Output conditions

Terminator	<TR> (0DH or 0D0AH)
Control code	<EOF>(1AH)
Code number	1
Final (Go)	500.0kg
Free fall (not in use)	10.0kg
Preliminary (Hi-Hi)	120.0kg
Optional preliminary (Lo-Lo)	350.0kg
Over limit (Hi)	10.0kg
Under limit (Lo)	20.0kg
Zero band	0.5kg
Full (not in use)	1000.0kg
Preset tare	123.4kg
Other code number	Factory setting (None)

Form E

Address: "None" (rSF-09=0)

```
01+0005000+0000100+0001200+0003500+0000100+0000200+0000005+0010000+0001234<TR>
```

Address: "1" (rSF-09=1)

```
@0101+0005000+0000100+0001200+0003500+0000100+0000200+0000005+0010000+0001234<TR>
```

Form F

* Factory setting: rSF-02 = "5" (Command mode)

Address: "None" (rSF-09=0)

```
FNC00,+00000001<TR>FNC01,+00000000<TR>FNC02,+00000000<TR>FNC03,+00000001<TR>
FNC04,+00000000<TR>FNC05,+00000000<TR>FNC06,+00000048<TR>FNC07,+00000001<TR>
FNC08,+00000001<TR>FNC09,+00000000<TR>FNC10,+00000001<TR>FNC11,+00000001<TR>
FNC12,+00000001<TR>FNC13,+00000001<TR>FNC14,+00000000<TR>FNC15,+00000000<TR>
SQ 01,+00000001<TR>SQ 02,+00000000<TR>SQ 03,+00000000<TR>SQ 04,+00000000<TR>
SQ 05,+000003.0<TR>SQ 06,+00000002<TR>SQ 07,+00000001<TR>SQ 08,+00000000<TR>
SQ 09,+000000.0<TR>SQ 10,+000000.0<TR>SQ 11,+000000.0<TR>SQ 12,+000000.0<TR>
SQ 13,+000000.1<TR>SQ 14,+000000.0<TR>SQ 15,+00000000<TR>SQ 16,+00000.10<TR>
SQ 17,+000000.1<TR>SQ 18,+000000.0<TR>SQ 19,+000000.1<TR>SQ 20,+00000000<TR>
SQ 21,+00000000<TR>SQ 22,+00000000<TR>SQ 23,+00000000<TR>SQ 24,+00000000<TR>
SQ 25,+00000000<TR>SQ 26,+00000000<TR>SQ 27,+00000000<TR>SQ 28,+000003.0<TR>
SQ 29,+00000000<TR>↓
IN 01,+00000001<TR>IN 02,+00000002<TR>IN 03,+00000003<TR>
IN 04,+00000004<TR>IN 05,+00000005<TR>IN 06,+00000006<TR>
OUT01,+00000001<TR>OUT02,+00000002<TR>OUT03,+00000003<TR>
OUT04,+00000004<TR>OUT05,+00000005<TR>OUT06,+00000006<TR>
SI 01,+00000001<TR>SI 02,+00000001<TR>SI 03,+00000002<TR>SI 04,+00000000<TR>
RS 01,+00000001<TR>RS 02,+00000005<TR>RS 03,+00000005<TR>RS 04,+00000002<TR>RS 05,+00000007<TR>
RS 06,+00000001<TR>RS 07,+00000002<TR>RS 08,+00000001<TR>RS 09,+00000000<TR>RS 10,+00000000<TR>
AN 01,+00000001<TR>AN 02,+00000000<TR>AN 03,+00010000<TR>
CAL01,+00000002<TR>CAL02,+00000000<TR>CAL03,+00000001<TR>CAL04,+00010000<TR>
CAL05,+00000002<TR>CAL06,+000000.0<TR>CAL07,+00000000<TR>CAL08,+000001.0<TR>
CAL09,+00000002<TR>CAL10,+00000001<TR>CAL11,+00000001<TR>CAL12,+00000001<TR>
CAL13,+00000001<TR>CAL14,+00000003<TR>CAL15,+00000001<TR>CAL16,+00000000<TR>
CAL17,+00000000<TR>CAL18,+00000000<TR>CAL19,+0.000031<TR>CAL20,+0.984587<TR>
CAL21,+00010000<TR><EOF>
```

Address : "1" (rSF-09=1)

```
@01FNC00,+00000001<TR>@01FNC01,+00000000<TR>@01FNC02,+00000000<TR>@01FNC03,+00000001<TR>
@01FNC04,+00000000<TR>@01FNC05,+00000000<TR>@01FNC06,+00000048<TR>@01FNC07,+00000001<TR>
:
:
:
@01CAL17,+00000000<TR>@01CAL18,+00000000<TR>@01CAL19,+0.000031<TR>@01CAL20,+0.984587<TR>
@01CAL21,+001000.0<TR><EOF>
```

Form G

Address: "None" (rSF-09=0, CALF-14=1~5, Customer Programmed Control Mode/ Built-in automatic program mode weighing)

```
CODE 00,FINAL +000000.0,F FALL+000000.0,PRELIM+000000.0,OP PLM+000000.0,OVER +000000.0,
UNDER +000000.0,Z BAND+000000.0,FULL +000000.0,TARE +000000.0,TTL WT+000000.0,TTL NO+00
000000,TTL OF+00000000,TTL UF+00000000,NO OF +00000000<TR>
CODE 01,FINAL +000500.0,F FALL+000010.0,PRELIM+000120.0,OP PLM+000350.0,OVER +000010.0,
UNDER +000020.0,Z BAND+000000.5,FULL +001000.0,TARE +000123.4,TTL WT+000000.0,TTL NO+00
000000,TTL OF+00000000,TTL UF+00000000,NO OF +00000000<TR>
CODE 02,FINAL +000000.0,F FALL+000000.0,PRELIM+000000.0,OP PLM+000000.0,OVER +000000.0,
UNDER +000000.0,Z BAND+000000.0,FULL +000000.0,TARE +000000.0,TTL WT+000000.0,TTL NO+00
000000,TTL OF+00000000,TTL UF+00000000,NO OF +00000000<TR>
CODE 03,FINAL +000000.0,F FALL+000000.0,PRELIM+000000.0,OP PLM+000000.0,OVER +000000.0,
UNDER +000000.0,Z BAND+000000.0,FULL +000000.0,TARE +000000.0,TTL WT+000000.0,TTL NO+00
000000,TTL OF+00000000,TTL UF+00000000,NO OF +00000000<TR>
CODE 04,FINAL +000000.0,F FALL+000000.0,PRELIM+000000.0,OP PLM+000000.0,OVER +000000.0,
UNDER +000000.0,Z BAND+000000.0,FULL +000000.0,TARE +000000.0,TTL WT+000000.0,TTL NO+00
000000,TTL OF+00000000,TTL UF+00000000,NO OF +00000000<TR>
CODE 05,FINAL +000000.0,F FALL+000000.0,PRELIM+000000.0,OP PLM+000000.0,OVER +000000.0,
UNDER +000000.0,Z BAND+000000.0,FULL +000000.0,TARE +000000.0,TTL WT+000000.0,TTL NO+00
000000,TTL OF+00000000,TTL UF+00000000,NO OF +00000000<TR>
.
.
.
CODE 95,FINAL +000000.0,F FALL+000000.0,PRELIM+000000.0,OP PLM+000000.0,OVER +000000.0,
UNDER +000000.0,Z BAND+000000.0,FULL +000000.0,TARE +000000.0,TTL WT+000000.0,TTL NO+00
000000,TTL OF+00000000,TTL UF+00000000,NO OF +00000000<TR>
CODE 96,FINAL +000000.0,F FALL+000000.0,PRELIM+000000.0,OP PLM+000000.0,OVER +000000.0,
UNDER +000000.0,Z BAND+000000.0,FULL +000000.0,TARE +000000.0,TTL WT+000000.0,TTL NO+00
000000,TTL OF+00000000,TTL UF+00000000,NO OF +00000000<TR>
CODE 97,FINAL +000000.0,F FALL+000000.0,PRELIM+000000.0,OP PLM+000000.0,OVER +000000.0,
UNDER +000000.0,Z BAND+000000.0,FULL +000000.0,TARE +000000.0,TTL WT+000000.0,TTL NO+00
000000,TTL OF+00000000,TTL UF+00000000,NO OF +00000000<TR>
CODE 98,FINAL +000000.0,F FALL+000000.0,PRELIM+000000.0,OP PLM+000000.0,OVER +000000.0,
UNDER +000000.0,Z BAND+000000.0,FULL +000000.0,TARE +000000.0,TTL WT+000000.0,TTL NO+00
000000,TTL OF+00000000,TTL UF+00000000,NO OF +00000000<TR>
CODE 99,FINAL +000000.0,F FALL+000000.0,PRELIM+000000.0,OP PLM+000000.0,OVER +000000.0,
UNDER +000000.0,Z BAND+000000.0,FULL +000000.0,TARE +000000.0,TTL WT+000000.0,TTL NO+00
000000,TTL OF+00000000,TTL UF+00000000,NO OF +00000000<TR><EOF>
```

Address: "1" (rSF-09=1, CALF-14=1~5, Customer Programmed Control Mode/ Built-in automatic program mode weighing)

```
@01CODE 00,FINAL +000000.0,F FALL+000000.0,PRELIM+000000.0,OP PLM+000000.0,OVER +000000.0,
UNDER +000000.0,Z BAND+000000.0,FULL +000000.0,TARE +000000.0,TTL WT+000000.0,TTL NO+00000
00,TTL OF+00000000,TTL UF+00000000,NO OF +00000000<TR>
@01CODE 01,FINAL +000500.0,F FALL+000010.0,PRELIM+000120.0,OP PLM+000350.0,OVER +000010.0,
UNDER +000020.0,Z BAND+000000.5,FULL +001000.0,TARE +000123.4,TTL WT+000000.0,TTL NO+00000
00,TTL OF+00000000,TTL UF+00000000,NO OF +00000000<TR>
.
.
.
@01CODE 99,FINAL +000000.0,F FALL+000000.0,PRELIM+000000.0,OP PLM+000000.0,OVER +000000.0,
UNDER +000000.0,Z BAND+000000.0,FULL +000000.0,TARE +000000.0,TTL WT+000000.0,TTL NO+00000
00,TTL OF+00000000,TTL UF+00000000,NO OF +00000000<TR><EOF>
```

Address: "None" (rSF-09=0, CALF-14=6~9, Check weighing)

```
CODE 00, TARGET+000000.0,      +000000.0, Hi-Hi +000000.0, Lo-Lo +000000.0, Hi      +000000.0,
Lo  +000000.0, Z BAND+000000.0,      +000000.0, TARE  +000000.0, TTL WT+000000.0, TTL NO+00
000000, TTL OF+00000000, TTL UF+00000000, NO OF +00000000<TR>
CODE 01, TARGET+000500.0,      +000000.0, Hi-Hi +000120.0, Lo-Lo +000350.0, Hi      +000010.0,
Lo  +000020.0, Z BAND+000000.5,      +000000.0, TARE  +000123.4, TTL WT+000000.0, TTL NO+00
000000, TTL OF+00000000, TTL UF+00000000, NO OF +00000000<TR>
      .
      .
      .
CODE 99, TARGET+000000.0,      +000000.0, Hi-Hi +000000.0, Lo-Lo +000000.0, Hi      +000000.0,
Lo  +000000.0, Z BAND+000000.0,      +000000.0, TARE  +000000.0, TTL WT+000000.0, TTL NO+00
000000, TTL OF+00000000, TTL UF+00000000, NO OF +00000000<TR><EOF>
```

Address: "1" (rSF-09=1, CALF-14=6~9, Check weighing)

```
@01CODE 00, TARGET+000000.0,      +000000.0, Hi-Hi +000000.0, Lo-Lo +000000.0, Hi      +000000.0,
Lo  +000000.0, Z BAND+000000.0,      +000000.0, TARE  +000000.0, TTL WT+000000.0, TTL NO+000000
000, TTL OF+00000000, TTL UF+00000000, NO OF +00000000<TR>
@01CODE 01, TARGET+000500.0,      +000000.0, Hi-Hi +000120.0, Lo-Lo +000350.0, Hi      +000010.0,
Lo  +000020.0, Z BAND+000000.5,      +000000.0, TARE  +000123.4, TTL WT+000000.0, TTL NO+000000
000, TTL OF+00000000, TTL UF+00000000, NO OF +00000000<TR>
      .
      .
      .
@01CODE 99, TARGET+000000.0,      +000000.0, Hi-Hi +000000.0, Lo-Lo +000000.0, Hi      +000000.0,
Lo  +000000.0, Z BAND+000000.0,      +000000.0, TARE  +000000.0, TTL WT+000000.0, TTL NO+000000
000, TTL OF+00000000, TTL UF+00000000, NO OF +00000000<TR><EOF>
```

Reading data out from EEPROM (rSF-09)

Address: "None" (rSF-09=0)

```
00000281002AAC030000000000000000100000101010101020101010101000101000027100000001F000F06
0B000027100201010200000A0201010101030100000000000000000000000000002710000000001000001000030
0101000101010100000102030405060102030405060101020001050502070102010000010100001E0201000000
00000100000A010001000000000000000001E00<TR>
```

Address: "1" (rSF-09=1)

```
@0100000281002AAC030000000000000000100000101010101020101010101000101000027100000001F000
F060B000027100201010200000A020101010103010000000000000000000000000000002710000000001000001000
0300101000101010100000102030405060102030405060101020001050502070102010100010100001E0201000
00000000100000A010001000000000000000001E00<TR>
```

APPENDIX F: USER'S SETTING RECORD

Keep all the setting information for future maintenance.

Function Setting Record

Func. #	Function Name	Value	Func. #	Function Name	Value
FncF: Basic Functions			Sq F: Weighing Sequence Functions		
FncF-01	Key Operation		Sq -01	Selection of comparison weight	
FncF-02	[F] key function		Sq F-02	Automatic accumulation	
FncF-03	Display update rate		Sq F-03	Automatic free fall compensation	
FncF-04	Sub display		Sq F-04	Automatic free fall effective width	
FncF-05	<input type="checkbox"/> display		Sq F-05	Unstable Dribble Flow Time	
FncF-06	Digital filter		Sq F-06	Overlimit/ underlimit operation	
FncF-07	Sampling frequency dividing ratio		Sq F-07	Stability at judgment	
FncF-08	Hold operation		Sq F-08	Maximum number of supplementary flow times	
FncF-09	Comparison stop at hold		Sq F-09	Batch start wait timer	
FncF-10	Automatic return to the normal mode after indicating set point data		Sq F-10	Full-flow comparator inhibitor timer	
FncF-11	Preset tare weight by code		Sq F-11	Medium-flow comparator inhibitor timer	
FncF-12	Recalling set point data by code		Sq F-12	Dribble-flow comparator inhibitor timer	
FncF-13	Setting set point code by code		Sq F-13	Judgment wait timer	
FncF-14	Set point code NOT to be recalled by code		Sq F-14	Batch Finish output width	
FncF-15	Continuous command of accumulation / manual print		Sq F-15	Batch monitoring timer	
			Sq F-16	Supplementary flow open timer	
			Sq F-17	Supplementary flow close timer	
			Sq F-18	Discharge start wait timer	
			Sq F-19	Discharge valve close wait timer	
			Sq F-20	Discharging time monitor timer	
			Sq F-21	Add the final to zero band setting	
			Sq F-22	Add the final to full setting	
			Sq F-23	Batch start function key	
			Sq F-24	Emergency stop function key	
			Sq F-25	Discharge start function key	
			Sq F-26	Automatic Tare at batch start	
			Sq F-27	Buzzer	
			Sq F-28	Buzzer sounding time	
			Sq F-29	Saving automatic free fall compensation data	

Section	Function	Value
in F: Control I/O—Input		
in F-01	Pin #1 to #9 of control signal terminal inside the case	
in F-02		
in F-03		
in F-04		
in F-05		
in F-06		
outF: Control I/O—Output		
outF-01	Pin #10, 11, 14, 15, 18, and 19 of control signal terminal inside the case.	
outF-02		
outF-03		
outF-04		
outF-05		
outF-06		
SiF: Standard Serial Output		
SiF-01	Output data	
SiF-02	Data transmitting mode	
SiF-03	Baud rate (bps)	
SiF-04	Code number output	
rSF: OP-03(RS-422/485)OP-04 (RS-232C)		
rSF-01	Output data	
rSF -02	Data transmitting mode	
rSF -03	Baud rate bps	
rSF -04	Parity	
rSF -05	Character bit length	
rSF -06	Stop bit length	
rSF -07	Terminator	
rSF -08	RS-422/485 switching	
rSF -09	Address number	
rSF -10	Code number output	

Section	Function	Value
AnF: Analog Output		
AnF-01	Output data	
AnF-02	Weight value at 4 mA output	
AnF-03	Weight value at 20 mA output	
CALF: Calibration		
CALF-01	Weighing unit	
CALF-02	Decimal point position	
CALF-03	Minimum division	
CALF-04	Capacity	
CALF-05	Zero range	
CALF-06	Zero Tracking Time	
CALF-07	Zero Tracking Width	
CALF-08	Motion detection time	
CALF-09	Motion detection width	
CALF-10	Tare and zero compensation at unstable reading	
CALF-11	Tare at negative gross weight	
CALF-12	Standard Serial Output: Output When Weight value Is Overflowing or Unstable.	
CALF-13	RS-232C/-422/-485: Output When Weight value Is Overflowing or Unstable.	
CALF-14	Weighing mode	
CALF-15	Preset tare	
CALF-16	Distinguish between preset tare and tare	
CALF-17	Serial interface; Print preset tare value with net weight (Si F-01=3, rsF-01=3)	
CALF-18	Push-zero and tare-clear function when powered on and when the display is turned on.	
CALF-19	Zero Input Voltage	
CALF-20	Span Input Voltage (Capacity to zero)	
CALF-21	Weight against Span Input Voltage	

Set Point Setting Record

Item	Value
Tare	
Final	
Free fall	
Preliminary	
Optional preliminary	
Over limit	
Under limit	
Zero band	
Full	
Dribble-flow time (Use a stop watch to measure)	
Medium-flow time (Use a stop watch to measure)	
Full-flow time	
Target weight	
Hi-Hi limit	
Hi limit	
Lo limit	
Lo-Lo limit	