

AD-4327 SERIES

INSTRUCTION MANUAL

Instruction-AD-4327-series-v.1.b-94.07.10

WEIGHING INDICATOR
AD-4327A
AD-4327B

AND
A&D Company, Limited



Table of Contents

Section A • Outline	page A • 1
Outline and Functional Type Description	page A • 2
Section B • Installation and Power Supply	page B • 1
Installation	page B • 2
Power Supply	page B • 2
Installing Batteries	page B • 3
Connecting an A, C, Adaptor	page B • 4
Connection to a Load Cell	page B • 5
Section C • Description of Panels	page C • 1
Front Panel	page C • 2
Rear Panel	page C • 4
Section D • Calibration Mode	page D • 1
Calibration Method	page D • 2
Calibration Errors	page D • 6
Relation Between Load Cell Output and Input Sensitivity	page D • 8
Section E • Function Mode	page E • 1
F Functions	page E • 2
F Function Setting Method	page E • 3
F Function Contents	page E • 4
CF Functions	page E • 8
List of Functions	page E • 8
CF Functions Setting Method	page E • 8
CF Function Contents	page E • 10
Section F • Basic Operation	page F • 1
Zero	page F • 2
Tare Deduction	page F • 2
Tare Deduction Using TARE Key	page F • 2
Tare Deduction Using Numeric Keys	page F • 3
Tare Clearance	page F • 3
Gross Weight Display ↔ Net Weight Display Switching	page F • 3
Unit Switching (MODE Key)	page F • 3

Section G • Various Functions	page G • 1
Counting Mode	page G • 2
Operation of the Counting Scale	page G • 2
Unit Weight Recording	page G • 3
Comparator Function	page G • 4
Turning Comparator Function ON/OFF	page G • 4
HI/LO Limit Setting	page G • 4
Comparison Modes	page G • 6
Disabling Changes to the HI and LO Limits	page G • 6
Gravity Compensation Function	page G • 7
Using the Gravity Compensation Function	page G • 8
The Value of Gravity at Various Locations	page G • 12
World Map	page G • 13
Section H • Options	page H • 1
Serial Interface (OP-03, 04, 05)	page H • 2
Interface Specifications	page H • 3
Data Format	page H • 4
Interface Connections	page H • 6
Installation of Options	page H • 8
Section I • Specifications	page I • 1
A/D Conversion Unit	page I • 2
Front Panel	page I • 2
General Specifications	page I • 2
Options	page I • 2
Accessories	page I • 2
Dimensions	page I • 3

AD-4327 Series • Section A

Outline



Outline and Functional Type Description

The AD-4327A/B is a weighing indicator that amplifies, performs A/D conversion of the load cell output, and gives a digital display of the weight value.

The AD-4327A is a simple weighing indicator with a comparator, counting and automatic power off functions, that can be turned off using the "F" and "CF" function settings.

The AD-4327B includes all of the functions of the AD-4327A plus a 10 key pad for inputting various numerical values.

Both versions may be powered by battery or an AC adapter.

AD-4327 Series • Section B

Installation and Power Supply



Installation and Power Supply



Installation

The AD-4327A/B is a precision electronic instrument, and requires careful handling.

The operating temperature range is -10°C to $+40^{\circ}\text{C}$. It should be installed where it will not be exposed to direct sunlight.

The AD-4327A/B must be kept away from electrical noise sources, since only an extremely weak voltage is produced as the load cell output, and the cable connected to the AD-4327A/B is affected by noise sources which include pulse components.



Power Supply

- When the AC adapter is used

A stable power source must be used, since an unstable power source which includes an instantaneous noise component may result in misoperation.

- When dry batteries are used

Use fresh batteries, preferably alkaline type.



Installing Batteries

1

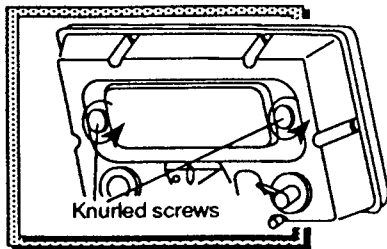

- ▶ Remove the battery compartment cover by undoing the 2 knurled securing screws and pulling the cover away from the rear of the display.

2

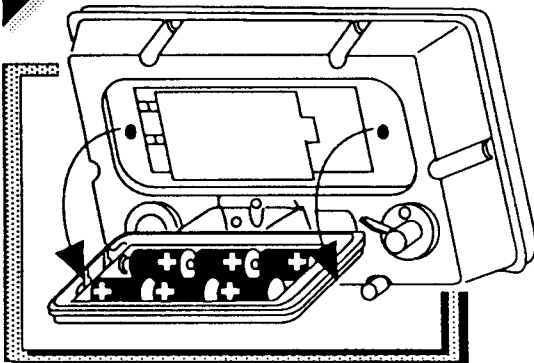

- ▶ Carefully install the 6 x C cells into the carrier observing the correct polarity as marked inside the battery cover.

3

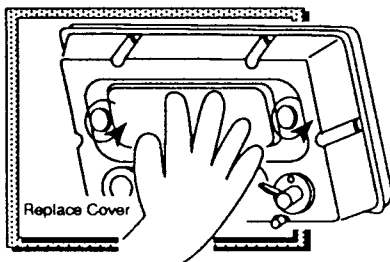

- ▶ Replace the cover and push home firmly.
- ▶ Tighten the 2 securing screws.



Connecting an A.C. Adaptor



Ensure that you have the correct AC adaptor for the voltage rating of your AC power source.

1

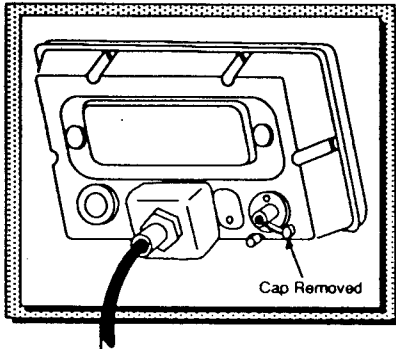

- ▶ Remove the cap, on its retaining strap, from the end of the adaptor inlet grommet.

2

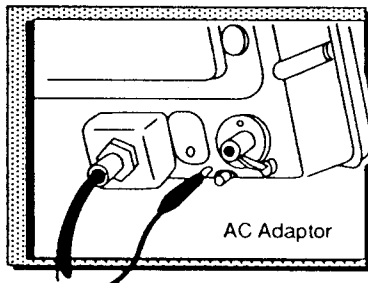

- ▶ Insert the adaptor flying output lead into the grommet and push firmly home into the socket.

Connection to a Load Cell

The method for connecting the AD-4327A/B to a load cell is shown here. Connect the load cell to the connector provided with the AD-4327.

Pin No.	Signal	Abbreviation
1	Load cell power supply +	EXC+
2	Sense input +	SEN+
3	Sense input -	SEN-
4	Load cell power supply -	EXC-
5	Load cell input +	SIG+
6	Load cell input -	SIG-
7	Shield	SHD



Information on connection to load cell

If the AD-4327A/B is close to the load cell (5m or less), it can be connected with a 4-wire shielded cable, with connectors 1 & 2 shorted and connectors 3 & 4 shorted.

If it is more than 5m away, it should be connected with a 6-wire shielded cable to prevent loss of weighing precision.

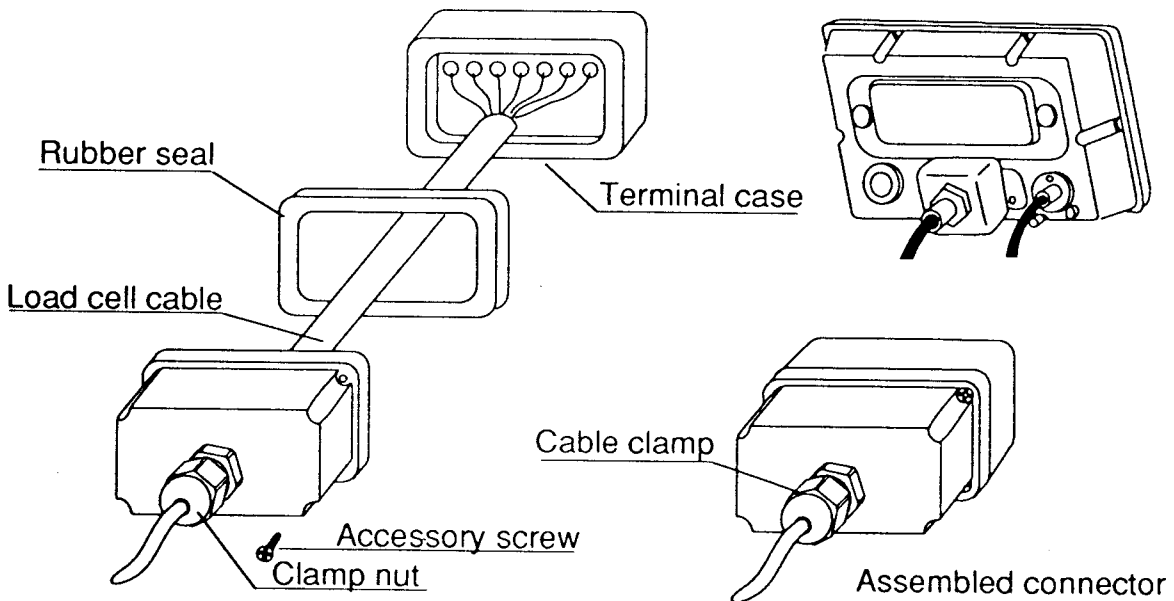

To assemble the load cell connector, loosen the clamp nut and pass the load cell cable through. After making the connections to the terminals, assemble as shown. Tighten the clamp nut. Use the accessory screws to seal the connector.

The specifications for the cable clamp: 5 ~ 10 mm in diameter. If a smaller clamp is used, remove the rubber accessory.

AD-4327 Series • Section C

**Description
of
Panels**



Description of Panels



Front Panel

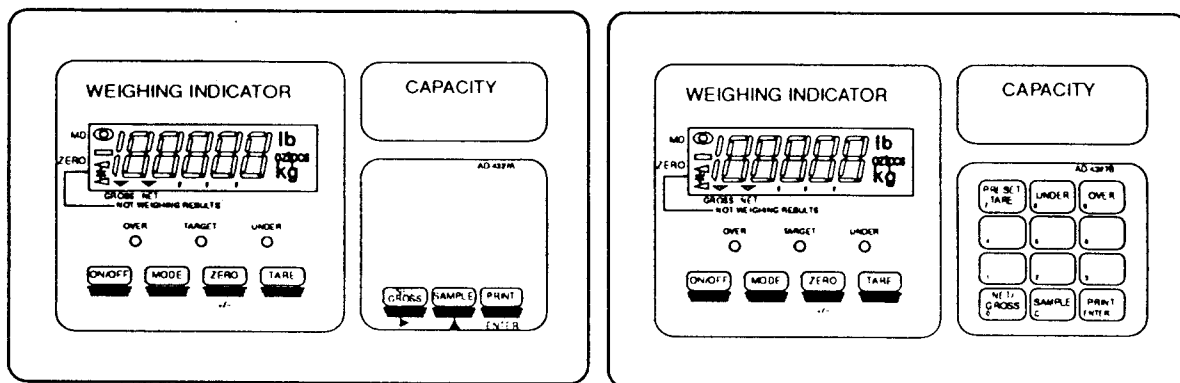

TOP VIEW

Key

- | | |
|----------------|---|
| ON/OFF | Turns power on/off. |
| MODE | Switches the unit. (See "Unit Switching"(page F • 3)) |
| ZERO | Sets the zero point. (See "Zero"(page F • 2)) |
| TARE | Sets the tare. (See "Tare Deduction"(page F • 2)) |
| NET /
GROSS | Switches between gross weight and net. (See "Gross Weight ↔ Net Weight Display Switching"(page F • 3)) |
| SAMPLE | Changes the number of samples at the time of PCS count unit weight recording. (See "Counting mode"(page G • 2)) |
| PRINT
ENTER | Outputs data to a peripheral device such as a printer, or saves the input data. |
| PRESET
TARE | Sets the preset tare. (See "Tare Deduction Using Numeric Keys"(page F • 2)) AD4327B only. |
| UNDER | Sets the comparator LO Limit. (See "HI/LO Limit Setting"(page G • 4)) |
| OVER | AD4327B only.
Sets the comparator HI Limit. (See "HI/LO Limit Setting"(page G • 4)) AD4327B only. |

B type

The following keys apply to the AD-4327B only.

Key

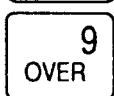
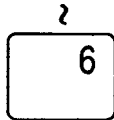

Numeric keys, 1 to 6

Used to input the preset tare value. Also used as numeric key 7.

Used to input the comparator LO Limit. Also used as numeric key 8.

Used to input the comparator HI Limit. Also used as numeric key 9.

Display Unit

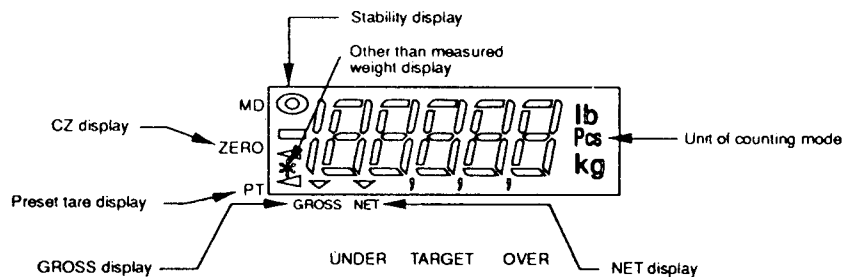

Weight over display

Plus over When GROSS data is greater than the capacity data plus 9 digits, display is blank.

Minus over When the measurement data is minus over or the GROSS data is smaller than the calibration zero data minus 20% of the capacity data. The numerical display will blank, leaving only the minus sign.

However, the unit, GROSS, NET and other annunciators are left. Also, when the comparator is operating, the comparison result is OVER or UNDER.

In the case of OVER, the weighing result output is replaced with spaces.



Rear Panel

- ❑ Calibration switch----- Used for calibration and some function settings
- ❑ Load cell connector----- Connects to the load cell cable.
- ❑ AC adapter jack----- Used to connect the AC adapter
- ❑ Option I/O connector----- Used to connect an option to an external system.

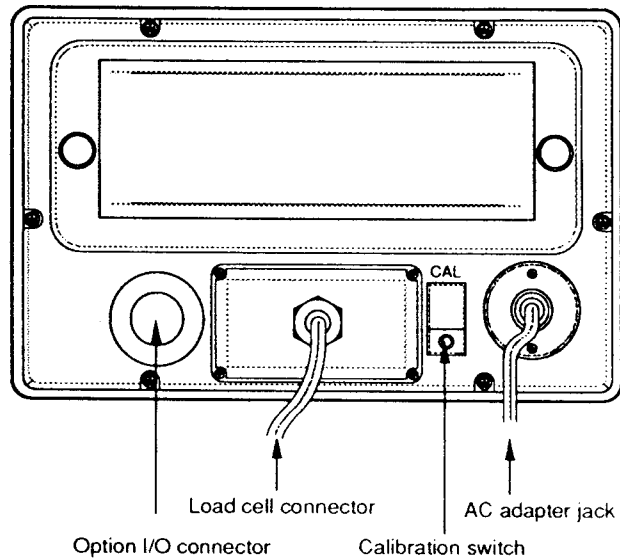

AD-4327 Series • Section D

Calibration Mode



Calibration Mode



Calibration Method

- In the calibration mode, the decimal point (see function setting) is not displayed. When a numeric value is set, it should be set as an item with a decimal point in the decimal point setting position.
- There are some differences in the setting method for the 4327A (A type) and 4327B (B type).

1 Connect the load cell and press the **ON/OFF** switch to turn the power on. All the segments are displayed, and the weighing state is entered about 5 seconds later.

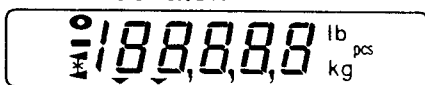

All-segment display

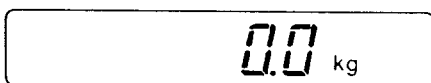

Weighing state
(The display may differ according to the setting state.)

This state should be maintained for a short time (about 10 minutes) to stabilize the load cell and the main unit.

* If the all-segment display does not change after 10 seconds, press **MODE** or **ZERO**.

2 Unit conversion between lb and kg is available (USA version only) and therefore calibration is possible using either unit.

Select the unit in which to perform calibration, specifying the mode.

If the desired unit is not displayed, set the CF-3 display unit to the desired unit (see page E • 3, "CF Function").

Conversion of the minimum division and maximum capacity is as follows.

Minimum division

kg	lb	
N/A	1	In this case kg cannot be used as a unit.
1	2	
2	5	
5	10	
10	20	
20	50	
50	N/A	In this case lb cannot be used as a unit.

Press the **CALIBRATION** switch.

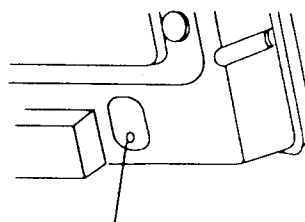

CALIBRATION switch

CAL

A message indicating that the calibration mode has been entered is displayed for approximately 2 seconds.

* From this point on, **ON/OFF** is not effective. To stop midway, see step number **7** "Termination".

3

Minimum division setting

d-01

← Current set value

Set the minimum division. A value of 1, 2, 5, 10, 20 or 50 can be set for the minimum division.

- When not changing the setting
Press **MODE** or **ENTER**.
- When changing the setting

A type

Each time **SAMPLE** is pressed, the setting changes in sequence: 1 → 2 → 5 → 10 → 20 → 50 → 1 → 2 → ... Select the minimum division to be set, and press **ENTER**.

B type

Use the numeric keys to make the setting. To make a correction, press **SAMPLE** and the value prior to setting will be returned to. Press **ENTER** to record the setting.

4

Maximum capacity setting

- If the converted value exceeds 10000 times the minimum division, the maximum capacity is set to 10000 times the minimum division.
- If the converted value exceeds 199999, the maximum capacity is set to 199999.

CAP

10000

← Current set value

Any number can be input as the maximum capacity, but a value for which the resolution (resolution = maximum capacity / minimum division) exceeds 10000 cannot be input. Also, a value that exceeds 199999 cannot be input.

A type

Use ▲ and ►.

▲ : Increments the flashing digit.

► : Shifts the flashing digit to the right.

(Does not flash during setting of the leftmost digit (/ digit).)

Press **ENTER** to record the setting.

B type

- When not changing the setting

Press **ENTER**.

- When changing the setting

Use the numeric keys to make the setting. If you make a mistake, press

SAMPLE and the value prior to setting will be returned to; you can then set the value again. Press **ENTER** to record the setting.

5

Zero calibration

CAL 0

Performs zero point adjustment. Check that there is nothing on the balance and that the stabilization symbol is displayed, then press the **ENTER** key. An error will result if the key is pressed when the stabilization symbol is not displayed.

- If zero adjustment is not necessary, press the **MODE** key.

6

Span calibration

SPRn

10000

← Weight value

Performs span adjustment. The maximum capacity value set in step number 4 is displayed, place weights equivalent to the maximum capacity on the balance, check that the stabilization symbol is display, then press the **ENTER** key. An error will result if the **ENTER** key is pressed when the stabilization symbol is not displayed.

- If span adjustment is not necessary
Press the **MODE** key. Span calibration is not performed, and the previous span is retained.
- If weights equivalent to the maximum capacity cannot be used
Prepare weights below and as near as possible to the maximum capacity.

A type

Use ▲ and ►.

▲ : Increments the flashing digit.

► : Shifts the flashing digit to the right.

(Does not flash during setting of the leftmost digit (/ digit).)

When the setting is completed, press **ENTER**

B type

Place these weights on the balance, then input that weight value.

Use the numeric keys to make the setting. If you make a mistake, press **SAMPLE** and the value prior to setting will be returned; you can then set the value again. When the setting is completed, press **ENTER**.

[OFF

7

Termination

- To terminate after validating the settings made so far
Press the **CALIBRATE** switch.

End

The calibration data is then written to the memory. Press **ON/OFF** to turn the power off.

- To terminate and cancel all the settings made so far
Hold down the **ZERO** key and press the **CALIBRATE** switch.

[AnLL

Press **ON/OFF** to turn the power off. The settings prior to entering the calibration mode remain.

- If you want to correct some settings made so far
Press the **MODE** key to return to step number 3 "Minimum division setting".



In zero and span calibration, the stabilization symbol indicates the stabilization state of the weighing system. Therefore, an error may result if **ENTER** is pressed when the stabilization symbol is not displayed. To ensure that calibration is performed correctly, check that the stabilization symbol is displayed before pressing **ENTER**. If the stabilization symbol is not displayed however long you wait, you should eliminate the external cause (floor vibration, air current, etc.).



Calibration Errors

If a calibration error of some kind is caused during calibration, a message will be displayed. The causes of errors, and the action to be taken, are shown below.

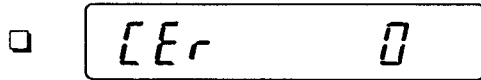

Displayed if a value other than 1, 2, 5, 10, 20 or 50 is input for minimum division. Input 1, 2, 5, 10, 20 or 50 as the minimum division.

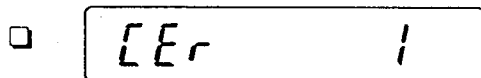

Displayed if the resolution exceeds 1/10000. The resolution is displayed as maximum capacity/minimum division. As the maximum resolution is 10000, you should either decrease the maximum capacity or increase the minimum division to give a value of 10000 or less.

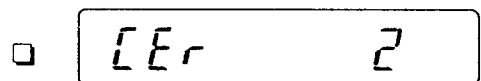

Displayed if the zero adjustment range is exceeded in the + direction. As the input signal range is -1 to 15mV, the zero point is greater than 15mV. Either decrease the initial load or connect a resistor as shown in "If the load cell output is too large" (page D • 8).

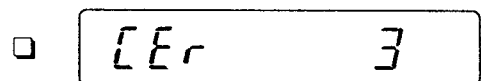

Displayed if the zero adjustment range is exceeded in the - direction. As the input signal range is -1 to 15mV, the zero point is smaller than -1mV. Either increase the initial load or connect a resistor as shown in "If the load cell output is too small" (Page D • 8).

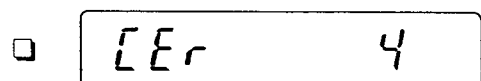

Displayed if the mounted weight value (keyed-in value) is greater than the maximum capacity when span calibration is performed.
Use a weight value which do not exceed the maximum capacity when performing span calibration.

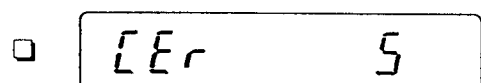

Displayed if the input weight value is less than the minimum division when span calibration is performed. Input a weight value equal to or greater than the minimum division.

□ [Er 6]

Displayed if the input sensitivity of the AD-4327A/B is not met because the load cell output voltage is too small for the span. Either change to a load cell with a higher output voltage or reduce the resolution by increasing the minimum division. See page D-9 for the relation between the load cell output voltage and the input sensitivity of the AD-4327A/B.

□ [Er 7]

Displayed if the load cell output when the weights are mounted is smaller than the zero point. Check for an error in the connection of the load cell, or reversal of the load cell load direction.

□ [Er 8]

Displayed if the load cell output voltage exceeds the maximum input voltage. If the load cell zero setting has drifted greatly in the + direction, insert a resistor as described in [Er 2] (page D-6). If an error is displayed even though the zero setting is OK, either change to a load cell with a smaller output voltage or decrease the maximum capacity.

□ [Er 9]

Occurs in the case of calibration zero or span input. The load cell output voltage at this time greatly exceeds the input range for the AD-4327A/B. Check the load cell output and connection.

- If the load cell output is too large

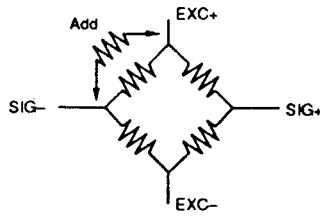

- If the load cell output is too small or negative.

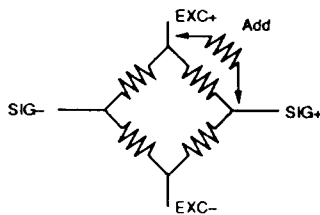

When adding a resistor, use a metal film resistor in the range 50 to 500 k Ω with a good temperature coefficient. The added resistor should be connected at a point near the AD-4327. Use as large a resistance value as possible in the range in which zero adjustment is possible.

If an error still occurs when the above method is used, check whether the load cell is defective or incorrectly connected.



Relation Between Load Cell Output and Input Sensitivity

The input sensitivity is $0.2 \mu\text{V}/\text{D}$ or more. The input sensitivity indicates the variation in the load cell output voltage required to change the display one point on the display. When designing a weighing system, the load cell output voltage must satisfy the input sensitivity of the AD-4327A/B. For this purpose, the system should be designed so that the following equations are satisfied. In order to achieve a system with stable performance, it should be designed so that the sensitivity is as great as possible.

- A: Load cell rated load
- B: Load cell rated output [mV/V]
- D: Minimum division
(5000 is the excitation voltage in millivolts)
(0.2 is the input sensitivity in μV)

$$0.2 \leq \frac{5000 \times B \times D}{A}$$

Example: To make a weighing system with a maximum capacity of 300kg and minimum division of 0.05kg, using a single load cell with ratings of 750kg and 3mV/V. In this example, $A=750$, $B=3$ and $D=0.05$, so that the right-hand side of equation a is as follows:

$$\frac{5000 \times 3 \times 0.05}{750} = 1$$

and equation a is satisfied. There is thus no problem with the design.

If multiple load cells are used, the design should ensure that the following equation is satisfied.

- N: Number of load cells

$$0.2 \leq \frac{5000 \times B \times D}{A \times N}$$

When a lever is used, the lever ratio should be taken into consideration.

- n = The lever ratio

$$0.2 \leq \frac{5000 \times B \times D}{A \times N \times n}$$

AD-4327 Series • Section E

Function Mode

Function Mode

Various features can be set by means of the F-functions. Set values are stored in nonvolatile memory, and thus are not lost when the batteries are removed or the AC adapter is disconnected.

Functions are divided into two kinds:

- F Functions Internal settings.
- CF Functions Calibration-related settings. These settings cannot be changed after certification, if a seal is affixed to the calibration switch access plate.

F Functions

List of Functions

F1	Filter	2d / 1.6 sec to 128 d / 3.2 sec
F2	Comparator function	No/Yes
F3	Auto power-off	No/Yes
F4	Comparison mode	Comparison disabled in case of zero proximity, minus, non-stabilization
F5	Comparator buzzer	Buzzer sounded according to comparator result
F6	Hi/Lo Limit change disabling	No/Yes

Serial interface related settings

These settings are not necessary if a serial interface (OP-03, 04, 05) is not used.

F7	Baud rate	600, 1200, 2400, 4800, 9600
F8	Output data	Display value, gross weight, net weight, tare weight, gross/net/tare
F9	Data output mode	Stream, auto-print, manual print, command
F10	Auto-print determination	+ data only, irrespective of +/-
F11	Output delay	No/Yes
F12	Weight unit during count display	lb / kg

F Function Setting Method

- There are some differences in the setting method for the AD-4327A and AD-4327B.

1 If the power is on, first turn the power off.

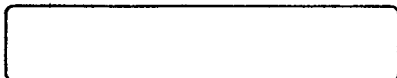

2 While holding down **ZERO** press **ON/OFF**.



3 Use the **▲** and **▶** keys to select the function number to be set.
(To set the number displayed, simply press **ENTER**.)



Use **▲** and **▶**.

- ▲ : Increments the flashing digit.
- ▶ : Shifts the flashing digit to the right.
(Does not flash during setting of the leftmost digit (/ digit).)

When the setting is completed, press **ENTER**.

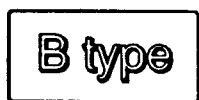

Use the numeric keys to make the setting. When the setting is completed, press **ENTER**.

(If you make a mistake, press **SAMPLE** and the value prior to setting will be returned; you can then set the value again.)

4 The value of that function number is displayed.



- When not changing the value
Press **ENTER**.
- When changing the value
Input method



Use **▲** and **▶**.

- ▲ : Increments the flashing digit.
- ▶ : Shifts the flashing digit to the right.
(Does not flash during setting of the leftmost digit (/ digit).)

When the setting is completed, press **ENTER**.

B type

Use the numeric keys to make the setting. When the setting is completed, press **ENTER**.

(If you make a mistake, press **SAMPLE** and the value prior to setting will be returned; you can then set the value again.)

5 The set value is memorized, and the next function number is displayed.

F - 02

→ F function number

Continue in the same way from step number 3.

6 To end, press **ON/OFF**.

F Functions Contents (* Indicates Factory Setting)

F-1	Average width / Averaging time			
0	2 d / 1.6 sec	7	2 d / 3.2sec	<div style="display: flex; align-items: center; justify-content: center;"> } ↓ Strong </div>
1	4 d / 1.6 sec	8*	4 d / 3.2sec	
2	8 d / 1.6 sec	9	8 d / 3.2sec	
3	16 d / 1.6 sec	10	16 d / 3.2sec	
4	32 d / 1.6 sec	11	32 d / 3.2sec	
5	64 d / 1.6 sec	12	64 d / 3.2sec	
6	128 d / 1.6 sec	13	128 d / 3.2sec	

If the filter is set as weak, the response will be faster, but will be more susceptible to external influences such as vibration. If the filter is set as strong, the response will be slower, but will be less susceptible to external influences such as vibration. You should select the appropriate filter for the weighing environment.

F-2	Comparator function
0	Not used *
1	Used

If "Not used" is set, the following applies:

- HI/LO Limit setting cannot be performed.
- The OVER, TARGET, UNDER displays do not light (except at power-on time).
- The buzzer is not sounded by the comparator.
- The comparator relay outputs are all turned off.

F-3	Auto-power-off function	
0	Not used *	
1	Used	

If "Used" is set, power is cut if the following states continue for approximately 5 minutes. When all the following are satisfied:

- Weight or PCS display is zero display
- Stabilization
- No key operation

F-4	Comparator mode	
0	All data compared *	
1	Comparison when stabilized only	
2	Items exceeding +5d compared	
3	Items exceeding +5d compared when stabilized only	
4	Items exceeding range -5d to +5d compared	
5	Items exceeding range -5d to +5d compared when stabilized only	

See "Comparator Function"(page G • 4) for an example of use, etc.

F-5	Comparator buzzer		
0	Does not sound *		
1	Sounds when LO		
2	Sounds when GO		
3	Sounds when LO & GO		
4	Sounds when HI		
5	Sounds when HI & LO		
6	Sounds when HI & GO		
7	Sounds when HI, GO & LO		

The buzzer can be sounded according to the comparator result. This is shown in diagrammatic form below.

Buzzer sounding place F-5 set value

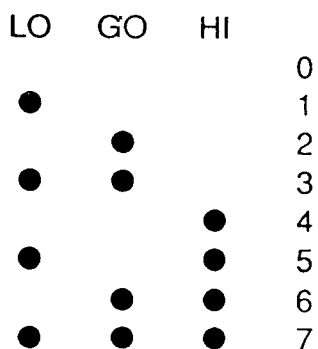

F-6	Comparator HI/LO Limit change disabling	
	0	Not disabled *
	1	Disabled

This function prevents the HI/LO Limits from being overwritten by mistake. The comparator function can still be used in the normal way even if "Disabled" is set.

Serial interface related settings (see "Serial Interface"(page H • 2) for details)
 These settings are not necessary if a serial interface (OP-03, 04, 05) is not used.

F-7	Baud rate	
	0	600(BPS)
	1	1200
	2	2400 *
	3	4800
	4	9600

In the case of current loop output (OP - 05), the instrument should not be used at 4800 or 9600 baud.

F-8	Output data	
	0	Display weight (net or gross weight or PCS) *
	1	Gross weight
	2	Net weight
	3	Tare weight
	4	Gross weight + net weight + tare weight

F-9	Serial interface output mode	
	0	Stream mode
	1	Auto-print mode
	2	Manual print mode *
	3	Command mode

F-10	Auto-print determination	
	0	+ data only *
	1	irrespective of +/-

F-11	Sets interval between data items in the case of multiple data output (approx. 2 seconds)	
	0	Not set *
	1	Set (valid when output mode is auto mode or manual mode)

F-12	Weight unit during count display (USA version only)	
	0	lb *
	1	kg

During count display, the following units become the above set units (valid when the display unit is kg/lb (CF3 = 4)).

- Units for serial output gross weight, net weight and tare weight
- Preset tare input

CF Functions

List of Functions

CF1	Decimal point position	None, 10 ¹ , 10 ² , 10 ³
CF2	PCS count function	No/Yes
CF3	Display unit	kg, t, g (lb, lb/kg USA version)
CF4	Zero range	2%, 10%
CF5	Zero track width	None, 0.5d/sec to 2.5d/sec
CF6	Zero track operation point	See page E•11
CF7	Stabilization detection	None, 0.5d/0.5 sec to 4.0/sec
CF8	Power-on zero	No/Yes
CF9	Decimal point form	. or ,
CF10	Preset tare disabling	Not disabled/Disabled

Serial interface related settings

These settings are not necessary if a serial interface (OP 03, 04, 05) is not used.

CF11	Tare data output mode	
CF12	Over, non-stabilization output	Yes/No
CF13	Tare differentiation (Preset, one touch)	Yes/No

CF Function Setting Method

- There are some differences in the setting method for the AD-4327A and AD-4327B.

1 If the power is on, first turn the power off.



2 Hold down **ZERO** and press **ON/OFF**.

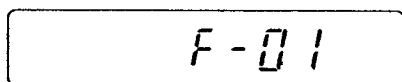

3 Press **CALIBRATION**.



4 Input the function number to be set.
(To set the number displayed, simply press **ENTER**.)

Method

A type

Use ▲ and ►.

- ▲ : Increments the flashing digit.
- : Shifts the flashing digit to the right.
(Does not flash during setting of the leftmost digit (1 digit).)

When the setting is completed, press **ENTER**.

B type

Use the numeric keys to make the setting. When the setting is completed, press **ENTER**.

(If you make a mistake, press **SAMPLE** and the value prior to setting will be returned; you can then set the value again.)

5

The value of that function number is displayed.

/

- When not changing the value
Press **ENTER**.
- When changing the value

Input method

A type

Use ▲ and ►.

- ▲ : Increments the flashing digit.
- : Shifts the flashing digit to the right.
(Does not flash during setting of the leftmost digit (1 digit).)

When the setting is completed, press **ENTER**.

B type

Use the numeric keys to make the setting. When the setting is completed, press **ENTER**.

(If you make a mistake, press **SAMPLE** and the value prior to setting will be returned; you can then set the value again.)

6

The set value is memorized, and the next function number is displayed.

[F-02]

→ Function number

Continue in the same way from step number 3.

To end, press **ON/OFF**.

CF Function Contents>(* Indicates Factory Setting)

CF-1	Decimal point position		
	Set Value	Decimal Point Position	Display Example
	0	None	12345
	1	10 ¹	1234.5 *
	2	10 ²	123.45
	3	10 ³	12.345

CF-2	PCS count function	
	0	PCS count used *
	1	PCS count not used

CF-3	Display unit	
	CF-3 Set Value	Display Unit
	0	kg *
	1	t
	2	g
	3	lb (USA version only)
	4	lb/kg (should be switched by the mode key or RS232-C command and USA version only)

CF-4	Zero range (valid range for ZERO key)	
	CF-4 Set Value	Zero Range
	0	±2% of maximum capacity *
	1	±10% of maximum capacity

Only valid in the range ±2% or ±10% with respect to the zero point when calibration is performed.

CF-5	Zero tracking width			
	CF-5 Set Value			
			5	2.5 divisions/1 sec
	0	No zero tracking	6	0.5 divisions/2 sec
	1	0.5 divisions/1 sec	7	1.0 divisions/2 sec
	2	1.0 divisions/1 sec	8	1.5 divisions/2 sec *
	3	1.5 divisions/1 sec	9	2.0 divisions/2 sec
	4	2.0 divisions/1 sec	10	2.5 divisions/2 sec

Zero tracking stabilizes the zero point by having the zero point of the AD-4327A/B track the slow drift of the zero point of the weighing system. The zero tracking condition is set by the zero tracking valid width and time. For example, if 1.5 divisions per 2 seconds is set, if the weight value is with ± 1.5 divisions of the zero point, and that state continues for 2 seconds, the zero point is tracked 1/4 division at a time. Therefore, if ± 1.5 divisions are exceeded, zero tracking cannot be performed. The tracking speed is 1 division per 4 seconds if the set value is between 1 and 5, and 1 division per 8 seconds if the set value is between 6 and 10. Zero tracking cannot be performed if the rate of change is faster than this. Zero tracking is not performed outside the range specified by the zero range (CF-4).

CF-6	Zero tracking object
0	Gross zero (during gross weight display only)
1	Gross zero (during gross or net weight display)
2	Gross zero (during gross or net weight display) or net zero (during net weight display) *

CF-7	Stabilization detection condition	
CF-7 Set Value	Stabilization detection condition	
0	Stabilization detection not performed	
1	0.5 divisions / 0.5 sec	
2	1.0 divisions / 0.5 sec	
3	2.0 divisions / 0.5 sec	
4	3.0 divisions / 0.5 sec	
5	4.0 divisions / 0.5 sec	
6	0.5 divisions / 1 sec	
7	1.0 divisions / 1 sec	
8	2.0 divisions / 1 sec *	
9	3.0 divisions / 1 sec	
10	4.0 divisions / 1 sec	

If the stabilization detection condition is 2 divisions per second, stabilization is judged to have been detected if the weight value varies within 2 divisions for 1 second. In comparatively rough weighing in which weighing speed is demanded, the stabilization detection width is made large, and the time short. When checking whether the unit is fully stabilized, the stabilization detection width is made small, and the time long. However, caution is required since stabilization is hard to achieve if there are influences such as vibration.

The **ZERO** and **TARE** keys are only valid when the instrument is stabilized, and therefore if you want these keys to be valid even when the instrument is unstable, you should set the value to 0.

CF-8	Power-on zero	
0	At power on, re-zero is not performed	
1	At power on, re-zero is performed *	

If “re-zero performed at power-on time” is set, re-zero is performed in the power-on state, and the weight display starts at zero.

However, if this state drifts 9% or more of the maximum capacity from the calibration zero, a zero-start is not performed.

CF-9	Decimal point form	
0	.	*
1	,	

CF-10	Preset tare deduction disabling	
0	Preset tare deduction not disabled *	
1	Preset tare deduction disabled	

Serial interface related settings (see “Serial Interface” (page H.2) for details)

These settings are not necessary if a serial interface (OP-03, 04, 05) is not used.

CF-11	Tare data output mode	
0	In accordance with F8 *	
1	If there is preset tare, the tare is always output irrespective of F8 (Valid only in manual and auto print mode)	

CF-12	Output in case of non-stabilization & over condition	
0	Output not performed in case of non-stabilization & over condition	
1	Output performed irrespective of non-stabilization & over condition * This setting does not affect the command mode.	

CF-13	Differentiates between one-touch tare deduction & preset tare deduction	
0	Not differentiated (vector 2 outputs TR for both) *	
1	Differentiated (one-touch tare deduction: TR) (preset tare deduction: PT)	

AD-4327 Series • Section F

Basic Operation

Basic Operation

Zero

If the zero point has drifted, pressing **ZERO** will correct it. However, **ZERO** is only valid in the range set as the zero range (CF-4). Normally this is only valid when the instrument is stabilized, but if CF-7 is set to 0, it will be valid at all times.

- In the case of gross weight display

Zero point has drifted



Press the **ZERO** key

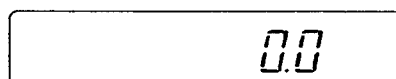

- In the case of net weight display

Tare (3000) has been performed
Zero point has drifted

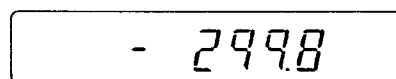

Press the **ZERO** key

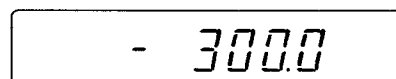

The **ZERO** key is not valid in the net weight display mode for the U.S.A. version.

Tare Deduction

Weights for which tare deduction can be performed are 1 division more or less than or equal to the maximum capacity.

If 3000 tare deduction is performed when the maximum capacity is 10000, the weighable net weight is 7000. When tare deduction is performed, the display automatically changes to the net weight display. Normally, the **TARE** key is only valid when the instrument is stabilized, but if CF-7 is set to 0, it will be valid at all times. (See "CF Functions" (page E •8))

Tare Deduction Using **TARE** Key (One-Touch Tare Deduction)

- Place the tare weigh on the weighing platform
- Press **TARE**. The weight display changes to net weight.

Tare Deduction Using Numeric Keys (Digital Tare Deduction)

B type ONLY

- Press **PRESET TARE**.

300.0

← When preset tare has been input

← When preset tare has not been input
In case of tare by one-touch tare deduction

- For example, for a tare deduction of 10.5, input **1**, **0**, **5**. The decimal point is fixed. (If you make a mistake, press **SAMPLE** and the value prior to setting will be returned; you can then set the value again.)

Press **ENTER**, and the display changes to the net display.

Tare Clearance

If the **TARE** key is pressed when the balance is at the zero point, the tare will be cleared. With the AD-4327B, the tare can also be cleared by inputting 0 in preset tare deduction.

Gross Weight Display ↔ Net Weight Display Switching

Pressing the **NET GROSS** key switches between gross weight display and net weight display. However, the display does not switch to net weight if the tare has been cleared.

Unit Switching (**MODE** Key)

Pressing the **MODE** key changes the unit. With the AD-4327A, comparator setting is also performed here.

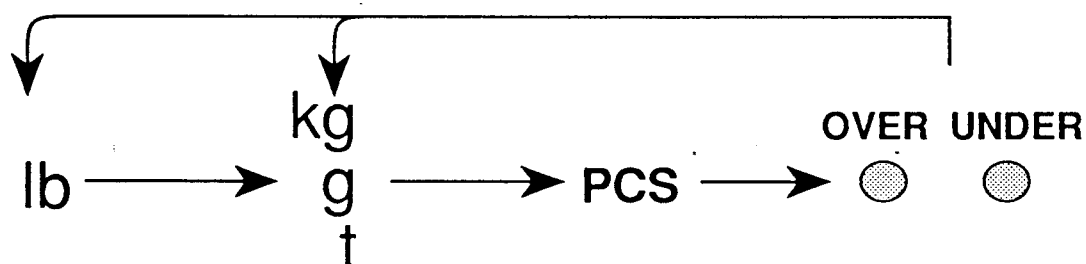

USA version only.
lb is selected
(CF3=4)

Unit selected
by CF3

When PCS count
can be used
(CF2=1)

"A" type only
When comparator
can be used (F2=1)
When Hi/Lo Limits
can be used (F5=0)

AD-4327 Series • Section G

Various Functions



Various Functions



Counting Mode

Operation of the Counting Scale

1 If **[MODE]** is pressed during the weight display, the Counting mode unit is displayed.

- If the Counting function is disabled, the Counting mode is not entered. Set CF function CF-2 to "Counting function used".

2 The unit weight recorded last time is used, and PCS display is performed.

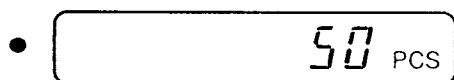

If the unit weight has not been recorded, proceed to step number 2 under "Unit weight recording" and record the unit weight. (The unit weight is deleted when the instrument is shipped, and after calibration.)

Unit Weight Recording

1 Press **[SAMPLE]** in the Counting mode.

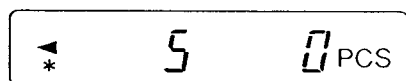

or

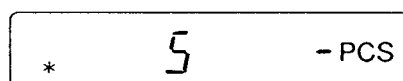

5 samples



PCS is unit of Counting mode.

- To abort
Press **[MODE]**.

2 Press **[SAMPLE]** and select the number of samples to be used as the standard. There are 5 standard numbers of samples: 5, 10, 20, 50 and 100. The larger the number of samples, the greater the precision.

3 Press **[ZERO]** or **[TARE]** to zero the display.

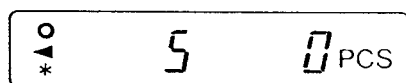

← set to 0.

This display **[5]** indicates that something (a container or sample, etc.) has been placed on the scale, or that the zero point has drifted. If the display shows **[5]** when there is nothing on the scale, press **[ZERO]** or **[TARE]** to display zero before placing a sample on the scale.

4 Place the selected number of samples on the weighing platform.

5 Check the stabilization symbol is displayed and press **ENTER**. The unit weight is then recorded.

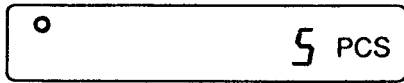

The recorded unit weight is stored internally, and is retained when the power is turned off.

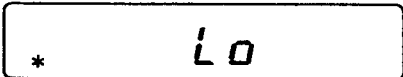
• If  is displayed

This indicates that the sample weight is too light. Increase the number of samples and record again.

If the sample weight is too light:

The weight of the samples mounted in step number 4 must be at least 25 times the minimum division.

Example: If the minimum division is 1g, select the number of samples so that the sample weight is 25g or more.



Comparator Function

This function checks whether a weight is within the prescribed range. The LO Limit and HI Limit are set, and a weight is judged to be in one of 3 categories: UNDER, TARGET, or OVER.

$$\text{UNDER} < \text{LO Limit} \leq \text{TARGET} \leq \text{HI Limit} < \text{OVER}$$

- Various comparison modes can be selected. F-4
- The internal buzzer can be sounded according to the judgment. F-5
- The comparator function can be turned on/off. F-2
- Change of the HI/LO Limits can be disabled. F-6
- If comparator relay output is necessary, OP-04 is used.
- The comparator can be used for either weight or counting mode. However, comparison is made with a value with the decimal point omitted.
Example: If the HI Limit setting is 10.0kg, in the counting mode, the HI Limit is treated as 100 pieces.

Turning Comparator Function On/Off

(See "F Functions "(page E • 2) for the setting method.)

F-2	Comparator function	
	0	Not used *
	1	Used

When the comparator function is to be used, select "Used".

If "Not used" is set, the following applies:

- HI/LO Limit setting cannot be performed.
- The UNDER, TARGET, or OVER displays do not light (except at power-on time).
- The buzzer is not sounded by the comparator.
- The comparator relay outputs are all turned off. (When OP-04 is installed)

HI/LO Limit Setting

- The set value is stored internally, and is retained when the power is turned off.
- In the "plus over" case, HI is set, and in the "minus over" case, LO is set.
- A HI/LO Limit size check is not performed. If LO Limit > HI Limit, the judgment is indeterminate.
- If the function setting is F2=0 (comparator not used) or F5=1 (HI/LO Limit change disabled), HI/LO Limit setting is not possible.
- There are some differences in the setting method for the AD-4327A and AD-4327B.

A type

- Set the weighing state (weight or number of Counting mode value display).

Press **MODE** until the following display appears.

Hi Limit setting



→ Current set value



Lo Limit setting



→ Current set value



- Set the value.

Use ▲ and ► and +/-.

▲ : Increments the flashing digit.

► : Shifts the flashing digit to the right.

(Does not flash during setting of the leftmost digit (/ digit).)

+/- : Sets positive/negative.

When the setting is completed, press **ENTER**. The set value is then stored.

- When **MODE** is pressed, the operation ends without updating the value.

- After setting the HI Limit, the LO Limit setting mode is entered. Set the LO Limit in the same way. After setting the LO Limit, the weight display appears.

B type

- Set the weighing state (weight or number of Counting mode value display).

- Press **OVER** to set the HI Limit.

UNDER to set the LO Limit.

- Use the numeric keys and **+/-** to make the setting. When the setting is completed, press **ENTER**.

The setting is stored internally and the weighing mode is returned to.

(If you make a mistake, press **SAMPLE** and the value prior to setting will be returned; you can then set the value again.)

Comparison Modes

One of the following 6 modes can be selected.

(See "F Functions "(page E • 2) for the setting method.)

F-4	
0	All data compared *
1	Comparison when stabilized only
2	Items exceeding +5d compared
3	Items exceeding +5d compared when stabilized only
4	Items exceeding range -5d to +5d compared
5	Items exceeding range -5d to +5d compared when stabilized only

- By selecting "when stabilized only", it is possible to turn off judgment of the state while an item is placed on the scale.
- By selecting "items exceeding +5d", it is possible to turn off judgment when an item is not placed on the scale.
- By selecting "items exceeding range -5d to +5d", it is possible to turn off judgment of proximity to zero when comparison of a negative value is performed.

Disabling Changes to the HI and LO Limits

If F5=1 is set, changes to the HI or LO Limit is disabled. (See "F Functions "(page E • 2) for the setting method.)

The comparator still operates in the normal way in this case.



Gravity Compensation Function



- ❑ This weighing indicator is equipped with a gravity compensation function which allows it to be calibrated in one location and then adjusted to match the acceleration of gravity at another location where it will be used.
- ❑ It is solely for this use (when the indicator is to be transported to a different geographical area), and it is not intended, nor needed for local or on-sight calibration.
- ⚠ SPAN Calibration should be done before the Gravity Compensation Function is used.
- ⚠ The first gravity setting, G-1, will be lost the next time you perform SPAN calibration.

Calibration of this indicator is required when it is initially installed, if the indicator is moved a substantial distance, or in accordance with local regulations. It is necessary because the weight of a mass in one location is not necessarily the same in another location. Also, with time and use, mechanical deviations can occur. "Weight" equals mass times acceleration due to Earth's field of gravity. The internationally adopted value for gravitational acceleration is 9.80665 m/s^2 (32.174 ft/s^2) in a vacuum. However, this varies by about ± 0.3 percent depending on how far you are from the Earth's center of mass. Mass distorts space in such a way that the gravitational power of attraction is inversely proportional to the square of the distance between material objects (if non-gravitational forces are ignored). So, gravitational acceleration is greatest at the poles, least at the equator and decreases with altitude.

When we weigh a mass, we are trying to find its weight expressed in pounds or kilograms. Because "g" and other factors vary from location to location, we must calibrate this indicator whenever we move it. Otherwise, a mass of 30kg might display 30.00kg in one location and 30.08kg in another (ie: "g" may have changed by +0.267%. $w=m \times g$). This would be an error, but it can be prevented by placing an accurate mass on the weighing device (say 30kg) and then telling this indicator, in effect, "this is what 30kg weighs at this location so please display 30.00kg"..... this is calibration.

- ❑ It is best to set the "g" with the actual value of gravity, measured at the location. This can be found in reference tables for the country (or area), or sometimes from a physics laboratory at a local academic institution. Also, if you know the latitude and altitude, you can use the following formula:

Helmert's formula can be used to find the value of "g", the acceleration due to terrestrial gravity, for a given latitude and altitude:

$$g = 9.806\ 16 - 0.025\ 928 \cos 2\lambda + 0.000\ 069 \cos^2 2\lambda - 0.000\ 003\ 086H$$

"g" is in m/s^2 , " λ " means latitude and "H" is meters above sea level.

- ❑ Alternatively, please refer to the attached table for the value of "g" at various world wide locations or plot the end-user's position in terms of latitude and altitude on the enclosed graph.



Using the Gravity Compensation Function

To perform gravity correction, the gravity of the location at which calibration was performed is first set. Then, span coordination is achieved by inputting the gravity of the location at which the instrument is to be used.

It is not necessary to set the gravity if the instrument is to be used where it was calibrated.

Example:

When the instrument was calibrated (minimum division: 1, maximum capacity: 10000) in Tokyo (gravity = 9.798m/s^2) and is to be used in Washington, D.C. (gravity = 9.803m/s^2).

When the instrument is to be used where it was calibrated.

Method

1 First perform calibration.

2 When calibration is completed, enter the calibration mode again.

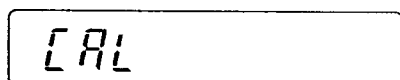

The message indicating that the calibration mode has been entered is displayed for approximately 2 seconds.

* From this point on, **ON/OFF** is not effective. To stop midway, press the **CAL** switch.

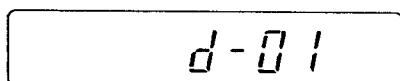

3 Press the **TARE** key.

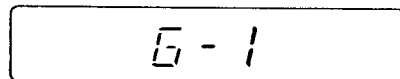

G-1 indicates the gravity of the location at which calibration was performed.

4 Input the gravity of the location at which calibration was performed. Here, the value for Tokyo, 9.798, is input. The decimal point is ignored.

A type

Use ▲ and ►.

▲ : Increments the flashing digit.

► : Shifts the flashing digit to the right.

(Does not flash during setting of the leftmost digit (/ digit).)

When **ENTER** is pressed, the setting is recorded.

B type

Use the numeric keys to make the setting. If you make a mistake, press **SAMPLE** and the value prior to setting will be returned; you can then set the value again.

When **ENTER** is pressed, the setting is recorded.

5

G-2

is displayed.

G-2 indicates the gravity of the location at which the instrument is to be used. After G-1 has been set, G-2 will have the same value as G-1.

6

Press **ENTER**.

End

Press **ON/OFF** to turn the power off.

G-1 indicates the gravity of the location at which calibration was performed, and G-2 indicates the gravity of the location at which the instrument is to be used. When G-1 is set in the above operations, G-2 is automatically made equal to G-1. This indicates that the gravity of the location at which calibration was performed and the gravity of the location at which the instrument is to be used are the same; that is, the instrument is to be used at the location at which calibration was performed. In this example, therefore, if the instrument is used in Tokyo, the span will be coordinated.

When changing the location where the instrument is to be used
Consider the case where the location where the instrument is to be used is changed to Washington, D.C. (gravity = 9.803m/s^2). If the instrument is used in Washington, D.C. without altering the setting, when a weight of 10000 is placed on the balance the display will show 9996. Therefore, the following operations must be performed to set G-2, the gravity (9.803) of the location where the instrument is to be used (Washington, D.C.).

1

Enter the calibration mode

CAL

The message indicating that the calibration mode has been entered is displayed for approximately 2 seconds.

* From this point on, **ON/OFF** is not effective. To stop midway, press the **CAL** switch.

d-01

2

Press the **TARE** key.

G-1

G-1 indicates the gravitational acceleration of the location at which calibration was performed.

3

Press the **ENTER** key.

G-2

After 2 seconds:

9798

4

Input the gravitational acceleration of the location at which the instrument is to be used.

Here, the value for Washington, D.C. 9803, is input. The decimal point is ignored.

A type

Use ▲ and ►.

▲ : Increments the flashing digit.

► : Shifts the flashing digit to the right.

(Does not flash during setting of the leftmost digit (/ digit).)

When **ENTER** is pressed, the setting is recorded.

B type

Use the numeric keys to make the setting. If you make a mistake, press **SAMPLE** and the value prior to setting will be returned; you can then set the value again.

When **ENTER** is pressed, the setting is recorded.

End

Press **ON/OFF** to turn the power off.

As a result of these operations, when a weight of 10000 is placed on the balance the display will show 10000. In this way, coordination with the span can be performed when the location at which the instrument is to be used is changed without preparing a weight.



The Value of Gravity at Various Locations

Amsterdam	9.813 m/s ²	Manila	9.784 m/s ²
Athens	9.800 m/s ²	Melbourne	9.800 m/s ²
Auckland NZ	9.799 m/s ²	Mexico City	9.779 m/s ²
Bangkok	9.783 m/s ²	Milan	9.806 m/s ²
Birmingham	9.813 m/s ²	New York	9.802 m/s ²
Brussels	9.811 m/s ²	Oslo	9.819 m/s ²
Buenos Aires	9.797 m/s ²	Ottawa	9.806 m/s ²
Calcutta	9.788 m/s ²	Paris	9.809 m/s ²
CapeTown	9.796 m/s ²	Rio de Janeiro	9.788 m/s ²
Chicago	9.803 m/s ²	Rome	9.803 m/s ²
Copenhagen	9.815 m/s ²	San Francisco	9.800 m/s ²
Cyprus	9.797 m/s ²	Singapore	9.781 m/s ²
Djakarta	9.781 m/s ²	Stockholm	9.818 m/s ²
Frankfurt	9.810 m/s ²	Sydney	9.797 m/s ²
Glasgow	9.816 m/s ²	Taichung	9.789 m/s ²
Havana	9.788 m/s ²	Taiwan	9.788 m/s ²
Helsinki	9.819 m/s ²	Taipei	9.790 m/s ²
Kuwait	9.793 m/s ²	Tokyo	9.798 m/s ²
Lisbon	9.801 m/s ²	Vancouver, BC	9.809 m/s ²
London (Greenwich)	9.812 m/s ²	Washington DC	9.801 m/s ²
Los Angeles	9.796 m/s ²	Wellington NZ	9.803 m/s ²
Madrid	9.800 m/s ²	Zurich	9.807 m/s ²

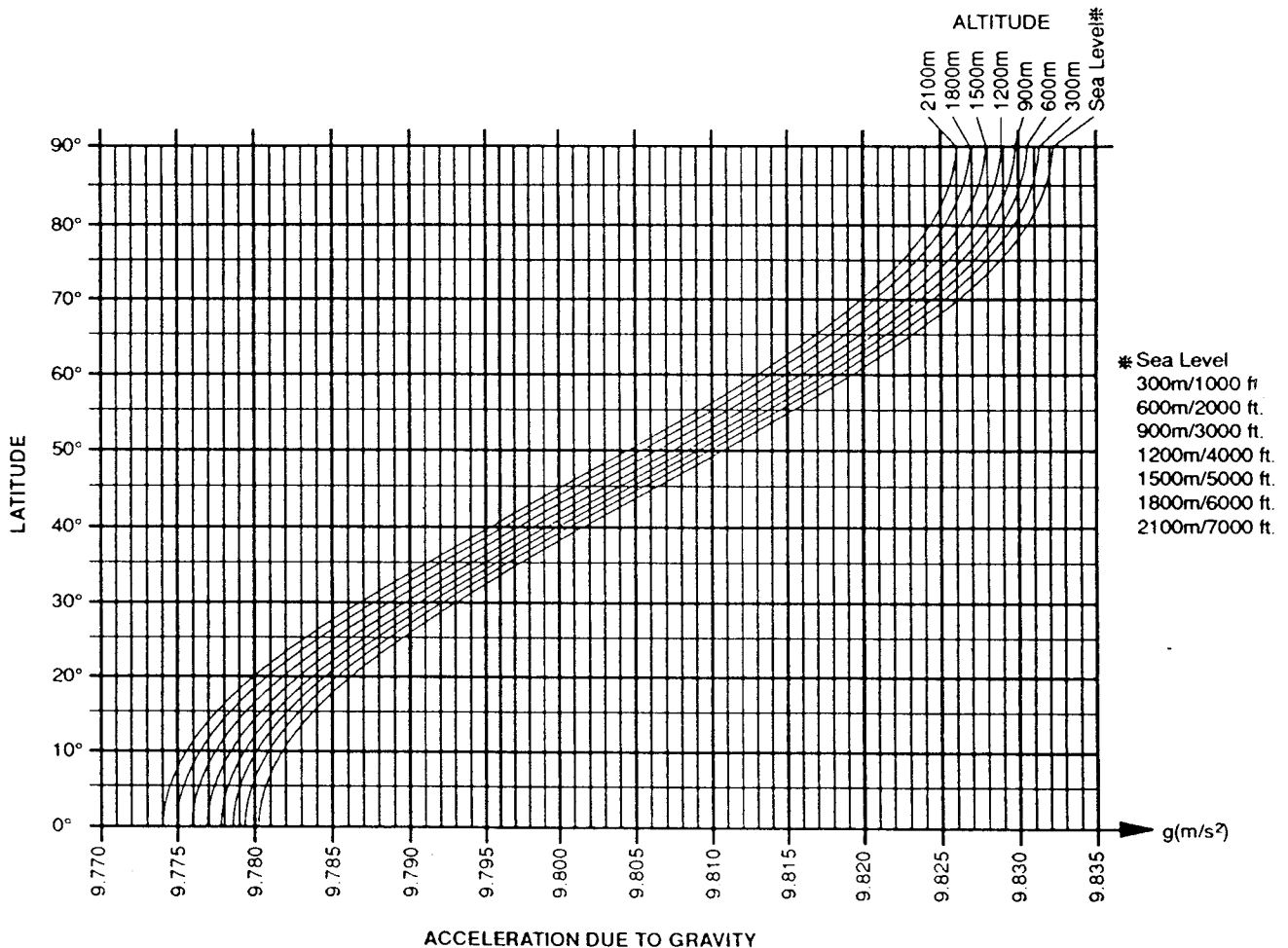



World Map

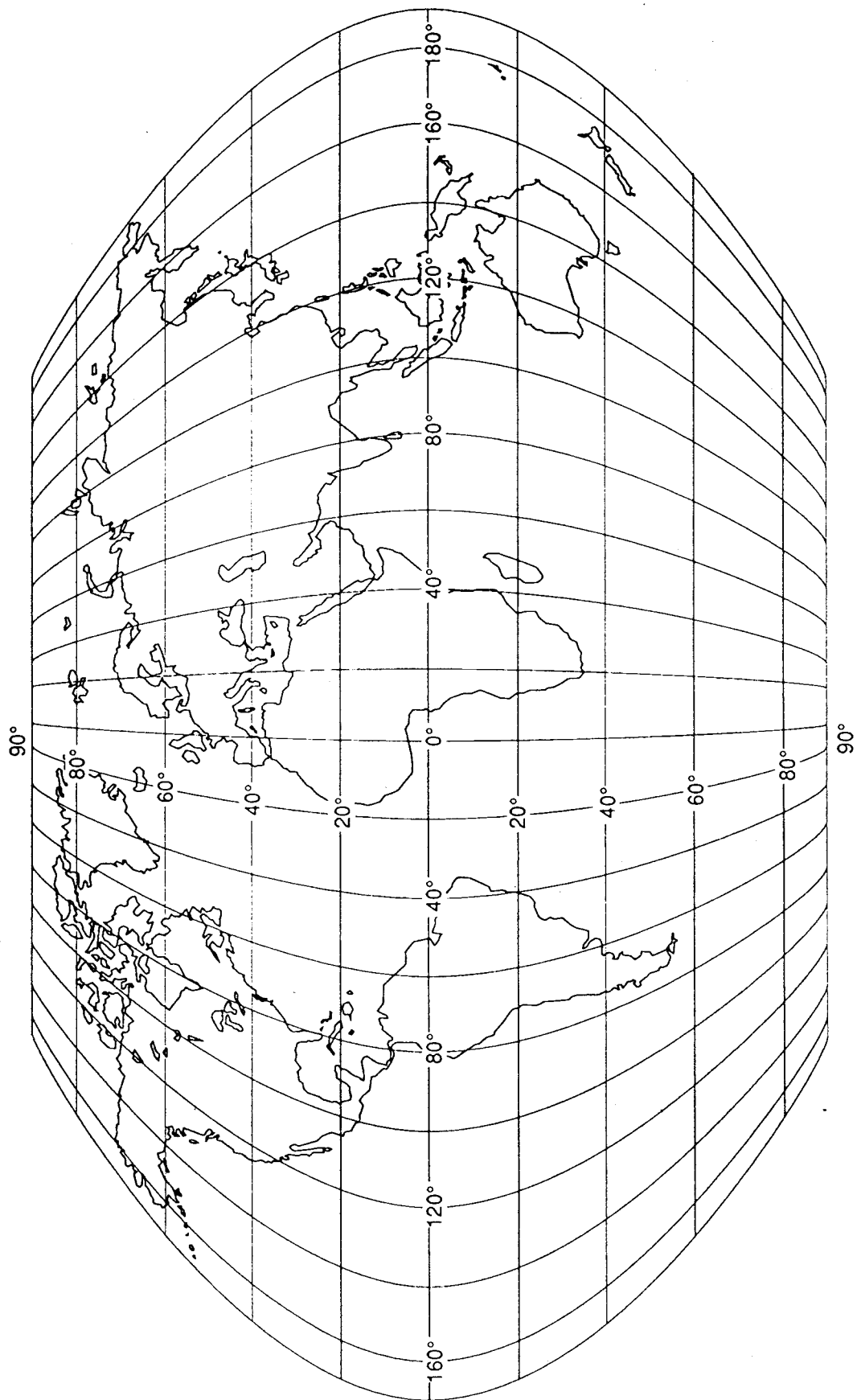

AD-4327 Series • Section H

Options



Options



Serial Interface (OP-03, 04, 05)

The serial options, OP-03 and OP-04, are for connection to a peripheral device, personal computer, etc. The input/output standards conform to EIA-RS-232C. Option OP-05, a 20mA current loop is an output only interface for connection to a printer or remote display.

Function Settings

The following functions are provided as settings for this function. Each function should be set before connection is performed. See the function mode section for the setting method.

F-7	Baud rate	
	0	600 (BPS)
	1	1200
	2	2400 *
	3	4800
	4	9600

In the case of current loop output (OP-05), the instrument should not be used at 4800 or 9600 baud.

F-8	Output data	
	0	Display weight (net or gross weight or PCS) *
	1	Gross weight
	2	Net weight
	3	Tare weight
	4	Gross weight + net weight + tare weight

F-9	Serial interface output mode	
	0	Stream mode
	1	Auto-print mode
	2	Manual mode *
	3	Command mode

F-10	Auto-print determination	
	0	+ data only *
	1	irrespective of +/-

F-11	Sets interval between data items in the case of multiple data output (approx. 2 seconds)	
0	Not set *	
1	Set (valid when output mode is auto-print mode or manual mode)	

Set to 1 when connecting the instrument to a printer which does not have a receive buffer, such as the AD8117, AD8117A, or AD8121.

CF-11	Tare data output	
0	In accordance with F-8 *	
1	If there is preset tare, the tare is also output when net weight output is performed. This setting is valid when F9 = 1 or 2 only.	

CF-12	Output in case of non-stabilization & over condition	
0	Output not performed in case of non-stabilization & over condition	
1	Output performed irrespective of non-stabilization & over condition *	

- This setting does not affect the command mode.
- When the “stabilization detection not performed” setting is made, header 1 outputs ST data irrespective of this setting.

CF-13	Differentiates between one-touch tare deduction & preset tare deduction	
0	Not differentiated (header 2 outputs TR for both) *	
1	Differentiated (one-touch tare deduction: TR) (preset tare deduction: PT)	

Interface Specifications

Method	Conforms to EIA-RS-232C	
Transmission method	Half-duplex, asynchronous	
Baud rate	600, 1200, 2400, 4800, 9600 (2400 or below when current loop is used)	
Data bits	7	
Parity bits	1 (even)	
Stop bits	1	
Code used	ASCII	
Output level	RS-232C	1: -5 to -15V 0: +5 to +15V
	20mA current loop	1: 20mA 0: 0mA

F-10 = 0

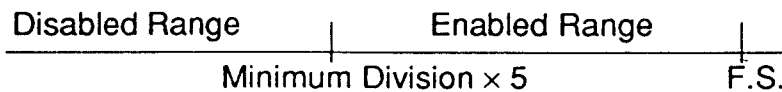

F-10 = 1

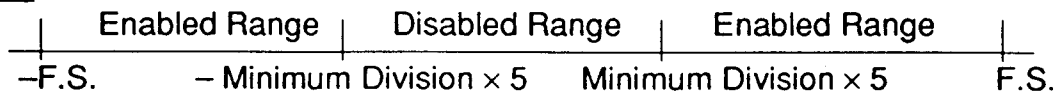

● **Manual print mode**

Output is performed once when the **PRINT** key is pressed.

● **Command mode** (RS-232C only)

The command mode is used when the AD-4327A/B is connected to a personal computer. In the command mode, when the AD-4327A/B receives a command, it performs the operation corresponding to that command and also sends back a response. Nothing is output unless a command is received. The command mode can only be used with RS-232C (OP-03 and OP-04).

□ **Commands**

RW command : Data request command. Display data is output immediately after the command is received.

MZ command : Performs a zero operation.

MT command : Performs tare deduction.

CT command : Clears the tare.

MG command : Switches the display to the gross weight display.

MN command : Switches the display to the net weight display.

CU command : Changes the unit. (Performs the same operation as **MODE**.)

PT command : Sets the preset tare.

Example: To set 100: PT,100 or PT,+100

(The decimal point should be ignored. If PT,100 is sent when the decimal point position is **00**, the value is treated as 10.0)

LO command : Sets the comparator LO Limit. (The set value is lost when the power is turned off)

Example: To set 100: LO,100 or LO,+100

To set -100: LO,-100

(The decimal point should be ignored. If LO,100 is sent when the decimal point position is **00**, the value is treated as 10.0)

HI command : Sets the comparator HI Limit. (The set value is lost when the power is turned off)

Example: To set 100: HI,100 or HI,+100

To set -100: HI,-100

(The decimal point should be ignored. If HI,100 is sent when the decimal point position is **00**, the value is treated as 10.0)



The set values of the LO and HI commands are not stored in memory. If you turn off the AD-4327, the set values are lost.

The command terminators are <CR><LF> or <CR>.

Therefore, when sending an RW command, you should send:

RW<CR><LF> or RW<CR>

52 57 0D 0A 52 57 0D

❑ Response to commands

When a command is received, the AD-4327A/B accepts that command, checks if the operation corresponding to that particular command is possible, and if it cannot comply with the command, sends back I<CR><LF>. If it can comply with the command, it outputs data in the case of the RW command, and in the case of other commands, sends back the received command. If it receives a command other than the eight kinds shown in the command mode list, it outputs ?<CR><LF>. If the indicator responds with a "?", check the command and the terminator.

- The symbols ">", "<>" and "<" are used in this text as separators, but should not be transmitted.

With the MT command and MZ command, the command is invalid if the instrument is unstable or the valid range is exceeded, in the same way as with the **TARE** key and **ZERO** key, and I<CR><LF> is sent back. Therefore, after sending a command, it is essential to accept and check the response before sending the next command.

Interface Connections

Pin Numbers for the 8-pin Din connector

- RS-232C (options 03, 04)

	Pin No.
DSR	7
TXD	3
RXD	2
GND	5

Used with RTS and CTS of the personal computer, etc..See page H•7 for circuit.

- Relay output (option 04 only)

	Pin No.
Hi	1
Go	6
Lo	4
COM	8

The output of each relay is tied to a common terminal (COM). See page H•7 for circuit.
Contact rating: Max. 50Vdc/100mA
On-resistance: 8 Ω or less

- Current loop (option 05)

	Pin No.
GND	2
SIGNAL	3&5
Not used	1, 4, 6, 7, 8

External power must be supplied as this output does not supply power (15VDC Max)
See page H•7 for circuit.

OP-03, 04 Interface Circuits

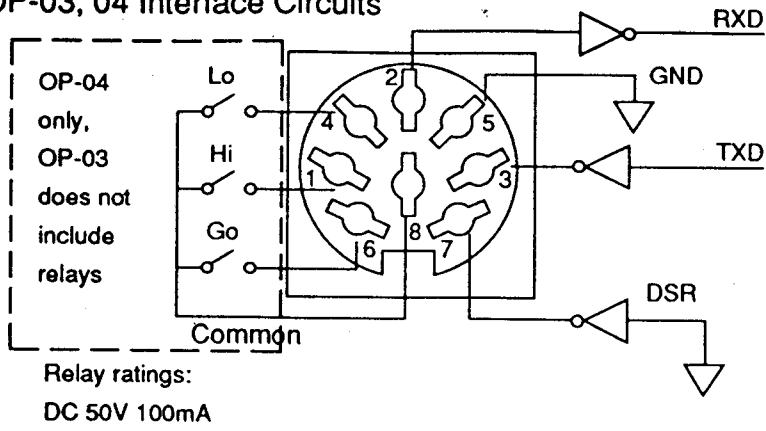

OP-05 Interface Circuit

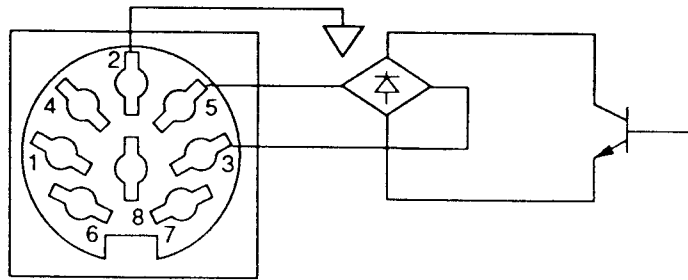

External current loop power source: Maximum 15V



Installation of Options 03, 04, 05

1

Remove the battery cover and the batteries (if used).

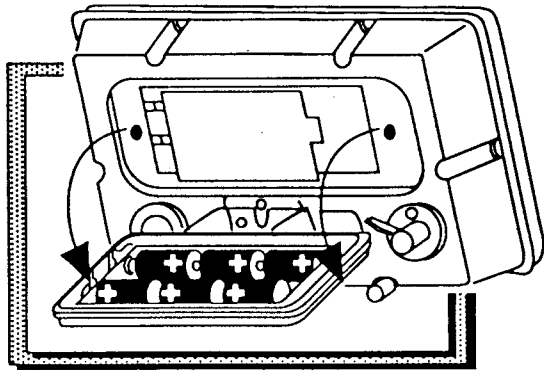

2

Insert the option.

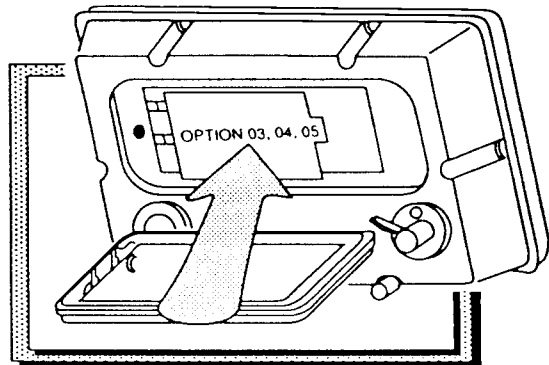

3

Replace the batteries (if used) and the battery cover.

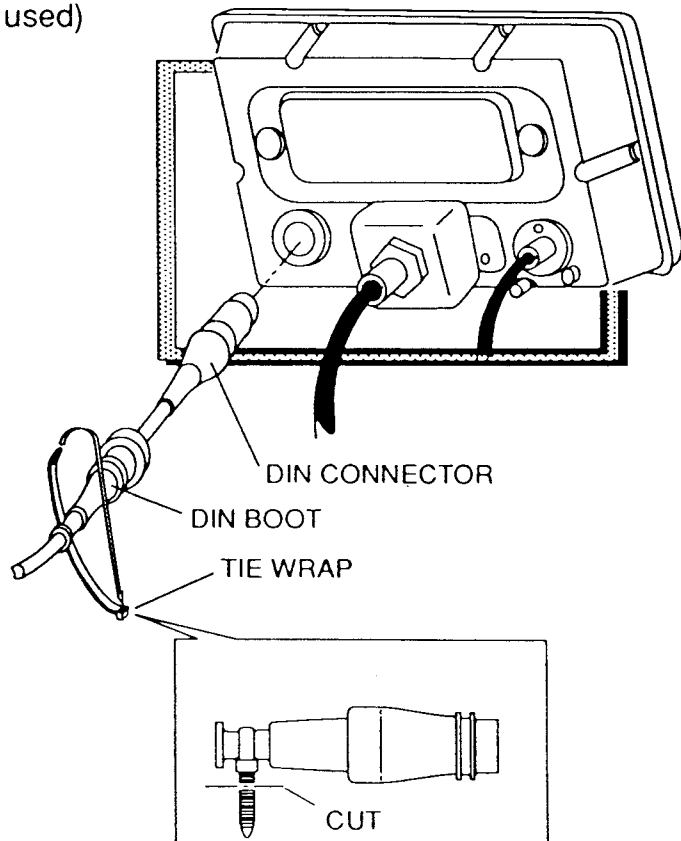

AD-4327 Series • Section I

Specifications



Specifications



A/D Conversion Unit

Input sensitivity	0.2 μ V/dmin (d = minimum division)
Input signal range	-1mV to 15mV
Load cell excitation voltage	5VDC \pm 5% (with remote sensing)
Load cell drive capacity	Max 6 units with 350 Ω load cell (max 90mA)
Zero point temperature coefficient	\pm (0.2 μ V \pm 0.0008% of zero adjustment voltage) / $^{\circ}$ C (TYP.)
Span temperature coefficient	\pm 8ppm/ $^{\circ}$ C of rdg (TYP.)
Non-linearity	0.01% of F.S.
Maximum input noise	\pm 0.2 μ V p-p
Input impedance	10M Ω or more
A/D conversion method	Integral type
Maximum display resolution	10,000d (divisions)
A/D conversion speed	Approx. 5 times/sec (same for display update)



Front Panel

7-segment liquid crystal display, character height: 22mm
 Selection of g, kg or t, lb or lb/kg; and pcs (number of items)



General Specifications

Power supply	AC adapter or 6 "C" size batteries
Weight	750g (approximately, excluding batteries)
Operating temperature range	-10 $^{\circ}$ C to 40 $^{\circ}$ C
Operating humidity range	85% RH or less (non condensing)
External dimensions	See dimensions on page I-3



Options

OP-03	RS-232C interface
OP-04	RS-232C interface + comparator relay output
OP-05	Printer interface (20mA current loop)



Accessories

Load cell connector	1 (NJC-207-PF)
AC adapter	1
Maximum capacity nameplate	1
Instruction Manual	1
Battery box	1

 Dimensions

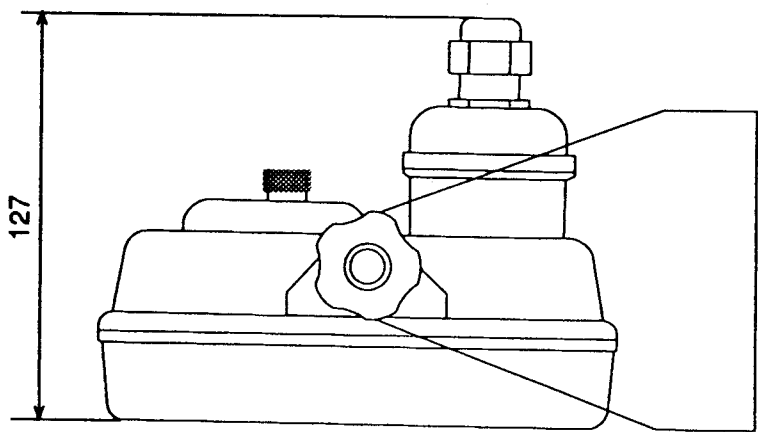

All values are in millimeters

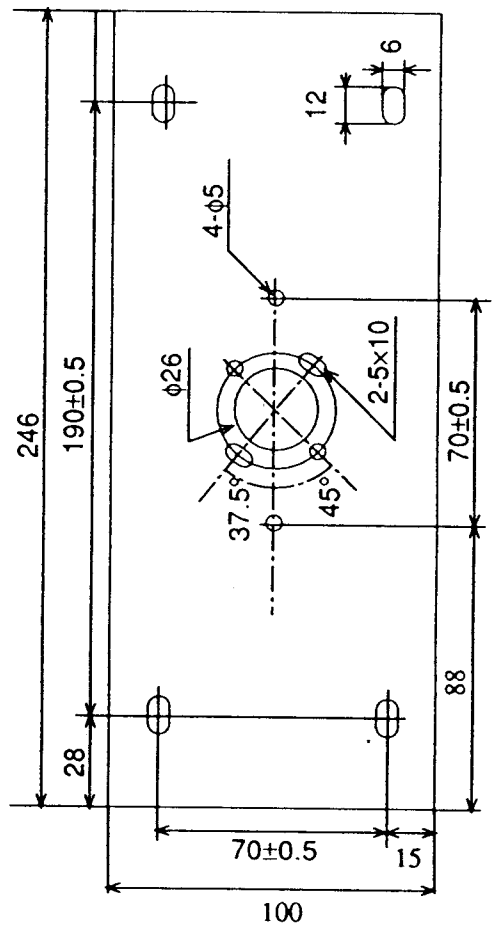
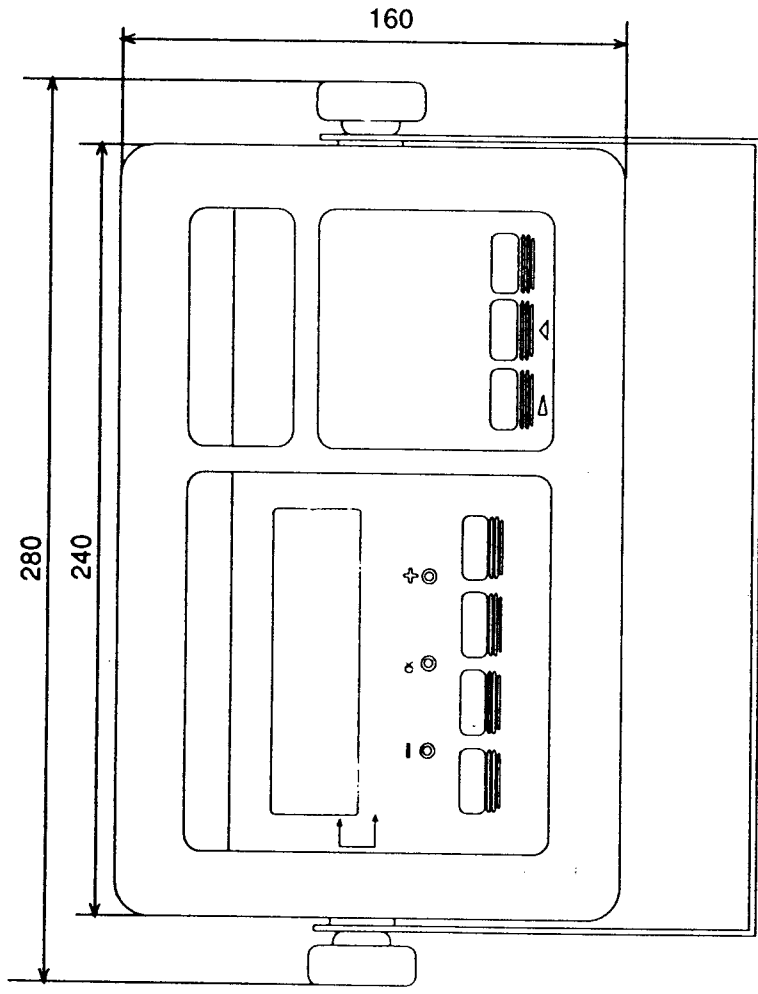



A&D Company, Limited

3-23-14 Higashi-Ikebukuro, Toshima-ku, Tokyo 170 JAPAN
Telephone: [81] (03) 5391-6132 Fax: [81] (03) 5391-6148

A&D ENGINEERING, INC.

1555 McCandless Drive, Milpitas, CA. 95035 U.S.A.
Telephone: [1] (408) 263-5333 Fax: [1] (408) 263-0119

A&D INSTRUMENTS LTD.

Abingdon Science Park, Abingdon, Oxford OX14 3YS ENGLAND
Telephone: [44] (0235) 550420 Fax: [44] (0235) 550485

< German Sales Office >

Genfer Strasse 6, Niedereschbach 60437 Frankfurt Main 50 GERMANY
Telephone: [49] (069) 507-1017 Fax: [49] (069) 507-2054

A&D MERCURY PTY. LTD.

32 Dew Street, Thebarton, South Australia 5031 AUSTRALIA
Telephone: [61] (08) 352-3033 Fax: [61] (08) 352-7409

A&D KOREA Limited

Seongmi Building 2/3F, 740-18 Panpo-1dong, Seocho-ku, Seoul, KOREA
Telephone: [82] (02) 517-4101 Fax: [82] (02) 546-4264