

**SV-A series**

**-Stand Type-**

**SV-H series**

**-Portable Type-**

**Vibro Viscometer**

INSTRUCTION MANUAL



© 2015 A&D Company, Limited. All rights reserved.

No part of this publication may be reproduced, transmitted, transcribed, or translated into any language in any form by any means without the written permission of A&D Company, Limited.

The contents of this manual and the specifications of the instrument covered by this manual are subject to change for improvement without notice.

# CONTENTS

<b>1. INTRODUCTION .....</b>	<b>3</b>
1-1 Compliance.....	3
1-1-1 Compliance with FCC Rules .....	3
1-1-2 Compliance with Council Directives .....	3
1-2 Features .....	5
<b>2. UNPACKING THE VISCOMETER .....</b>	<b>7</b>
2-1 Part Names for the SV-A Series (Stand type).....	7
2-2 Part Names for the SV-H Series (Portable type).....	13
<b>3. CHANGING TYPES .....</b>	<b>16</b>
3-1 Changing from the SV-H (Portable type) to the SV-A (Stand type) .....	16
<b>4. DISPLAY AND KEYS .....</b>	<b>19</b>
4-1 Display .....	19
4-2 Keys (For all models).....	20
4-3 Displaying the Viscosity Values .....	21
4-3-1 SV-1A/SV-1H .....	21
4-3-2 SV-10A/SV-10H .....	22
4-3-3 SV-100A/SV-100H .....	22
<b>5. PRECAUTIONS .....</b>	<b>23</b>
5-1 General Precautions (For all models).....	23
5-2 Precautions for an Accurate Measurement (Only for the SV-H series).....	23
5-3 During Use (For all models) .....	23
5-4 After Use (For all models).....	25
5-5 About Viscosity Measured (For all models) .....	27
5-5-1 At measurement .....	27
5-5-2 At calibration .....	28
<b>6. MEASUREMENT .....</b>	<b>29</b>
6-1 Preparing the Sample (For the SV-A series) .....	29
6-2 Basic Measurement Procedure (For the SV-A series) .....	32
6-3 Basic Measurement Procedure (For the SV-H series) .....	33
6-4 Changing Units (For all models).....	36
<b>7. USING THE WATER JACKET .....</b>	<b>37</b>
7-1 Introduction .....	37
7-2 Installation .....	38
7-3 How to Use .....	40
7-4 Measuring the Absolute Value of Viscosity Using the Small Sample Cup .....	41
7-5 Maintenance .....	41
7-6 Specifications.....	41
<b>8. USING THE DISPOSABLE CUP .....</b>	<b>42</b>
8-1 Introduction .....	42
8-2 How to use.....	42

8-2-1 Using with a sample cup (Capacity: 35 mL to 45 mL) .....	42
8-2-2 Using with the water jacket.....	42
8-3 Measuring the Absolute Value of Viscosity Using the Disposable Cup.....	43
8-4 Specifications.....	43
<b>9. VISCOSITY CALIBRATION (FOR ALL MODELS) .....</b>	<b>44</b>
9-1 Notes on Viscosity Calibration (For all models).....	44
9-2 Calibration Procedure (For all models).....	45
9-2-1 One-point calibration .....	46
9-2-2 Two-point calibration.....	47
9-2-3 Simplified calibration using purified water (SV-1A/1H/10A/10H).....	49
<b>10. FUNCTION SETTING (FOR ALL MODELS) .....</b>	<b>51</b>
10-1 Operation (For all models).....	51
10-2 Details of the Function Items (For all models).....	53
10-3 Description of Items (For all models).....	55
10-4 Data Output Format Examples (For all models).....	65
10-4-1 A&D standard format .....	65
10-4-2 D.P. format .....	67
10-4-3 CSV format .....	68
10-4-4 RsVisco format .....	72
<b>11. Connection to a Personal Computer.....</b>	<b>75</b>
11-1 Introduction .....	75
11-2 Installation of WinCT-Viscosity.....	75
11-3 Connection to a Personal Computer.....	76
11-4 Configuration of the COM Port .....	77
11-5 Controlling the Measurement Using a Personal Computer .....	78
<b>12. Connection to a printer (For all MODELS).....</b>	<b>79</b>
<b>13. RS-232C Serial Interface (For all MODELS).....</b>	<b>80</b>
<b>14. Command List (For all MODELS) .....</b>	<b>81</b>
<b>15. TROUBLESHOOTING (For all MODELS).....</b>	<b>82</b>
15-1 When Measurement Values do not Become Stable (For all models).....	82
15-2 When Measurement Values are not Correct (For all models) .....	84
15-3 When More Precise Measurement is Required: (For all models) .....	85
15-4 When the Temperature Values are not Correct (For all models).....	85
15-5 When Water Viscosity is to be Measured (Only for the SV-1A/1H/10A/10H).....	85
<b>16. ERROR DISPLAY (For all MODELS).....</b>	<b>86</b>
<b>17. SPECIFICATIONS.....</b>	<b>87</b>
<b>18. OPTIONAL ACCESSORIES .....</b>	<b>89</b>
<b>19. EXTERNAL DIMENSIONS .....</b>	<b>99</b>

# 1. INTRODUCTION

This manual describes how the SV-A/SV-H series viscometer works and how to get the most out of it in terms of performance.

Read this manual thoroughly before using the viscometer and keep it at hand for future reference.

The SV-A series uses a stand. In a laboratory, quality control room etc, you can make accurate measurements using the stand set, the sample cup set and the software set provided.

The SV-H series uses a handle only. While at a manufacturing location, you can make a measurement easily. If you buy the accessories, the SV-H series functions the same as the SV-A series.

## 1-1 Compliance

### Compliance with FCC Rules

Please note that this device generates, uses and can radiate radio frequency energy. This device has been tested and has been found to comply with the limits of a Class A computing device pursuant to Subpart J of Part 15 of FCC rules. These rules are designed to provide reasonable protection against interference when this device is operated in a commercial environment. If this unit is operated in a residential area, it may cause some interference and under these circumstances the user would be required to take, at his own expense, whatever measures are necessary to eliminate the interference.

(FCC = Federal Communications Commission in the U.S.A.)

### Compliance with Council Directives

 This device features radio interference suppression and safety regulation in compliance with the following Council Directives

Council directive 89/336/EEC	EN61326	EMC directive
Council directive 73/23/EEC	EN60950	Safety of Information Technology Equipment

 EN61326 Emission and Immunity.

#### Note

**The CE mark is an official mandatory European marking.**

**Please note that any electronic product must comply with local laws and regulations when sold or used anywhere outside Europe.**



A&D Instruments Ltd  
24 Blacklands Way  
Abingdon Business Park  
Abingdon, Oxfordshire  
OX14 1DY United Kingdom  
Tel: +44 (0)1235 550420  
Fax: +44 (0)1235 550485  
email: info@aandd-eu.net  
Internet: http://www.aandd-eu.net  
Vat No: GB 596 1273 15



A & D Instruments Ltd. hereby declare that the following weighing product conforms to the requirements of the council directives on ...

**Electromagnetic Compatibility (EMC) 89/336/EEC**

**Low voltage equipment (LVD) 73/23/EEC amended by 93/68/EEC**

provided that they bear the CE mark of conformity as shown above.

**SV Series Viscometer**

Standards applicable :

BS EN 61326 Electrical equipment for measurement, control and laboratory use - EMC requirements

BS EN 60950 Safety of Information Technology Equipment.

CE Mark First Applied June 2003

Signed for A&D Instruments in Oxford England April 2005

Takeo Goto  
Managing Director

*... Clearly a Better Value*



Registered in England No: 2609110 - Registered Office: 24 /26 Blacklands Way Abingdon Oxon OX14 1DY

## 1-2 Features

---

- High accuracy  
The Vibro Viscometer adopting the sine-wave vibration technique (SV type), achieves a high measurement accuracy of 1%\*<sup>1</sup> (repeatability) over the full range.  
\*1 With the SV-H series, when using the AX-SV-51 stand set (sold separately).  
Refer to "17. SPECIFICATIONS" on page 87.
- Measurement of a small amount of sample  
The SV-1A can measure a sample of 2 mL (minimum amount), and the standard X-Y-Z stage can position the sample container easily.  
When using the accessory items (sold separately), the SV-1H can measure a sample of 2 mL (minimum amount). For details, refer to "18. OPTIONAL ACCESSORIES"
- With the SV-H series, you can measure the viscosity at the manufacturing location by using the standard carrying case.
- The sensor plates are made of corrosion resistant titanium. Although titanium is a chemically stable material, it is corroded by some liquid such as sulfuric acid. So, handle it with much care.
- Wide range continuous measurement  
Continuous measurement over the whole measuring range is possible, without replacing the viscosity detection sensor plates.
- Standard temperature sensor  
The temperature sensor to measure the sample temperature is installed as standard. With the SV-1A/1H, the temperature sensor is located behind the two sensor plates. With the SV-10A/10H/100A/100H, the temperature sensor is located between the two sensor plates. So, the accurate detection of the relation between temperature and viscosity is possible.
- Accurate measurement  
Due to the low heat capacity of the viscosity detection unit (sensor plates), the time required for temperature equilibrium is short. Thus, the sample viscosity can be measured accurately in a short time.
- Long continuous measurement time  
The sensor plates, with a low frequency of 30 Hz and an amplitude of less than 1 mm, apply very little load to the sample. So, the viscometer can continuously obtain stable viscosity values without causing a temperature rise or damaging the sample. With the SV-H series, use the AX-SV-53 Software set-WinCT Viscosity (sold separately).
- Measurement of a non-Newtonian fluid/foaming sample  
The thin sensor plates allow little deformation of the sample texture. Thus, non-Newtonian fluid can be measured in a stable way. And, foaming samples (whipped cream, etc.) can be measured without breaking minute foam particles and with less influence scattering large foam particles  
When measuring tap water, bubbles may accumulate on the sensor plates, increasing the viscosity.
- Viscosity measurement of a flowing sample  
The two sensor plates oscillate in the opposite direction. So, even when a sample is in motion, errors are eliminated. This allows measurement of a sample while being stirred. Therefore, the viscometer can be used for a continuously flowing product line, which enables field management with identical data used at the laboratories.

- Calibration  
The viscometer can be calibrated using a standard viscosity fluid or a sample of a known viscosity. Calibration allows the viscometer to maintain the accuracy constantly.
- The vibro viscometer is accredited as a Japan Calibration Service System (JCSS) standard device, along with the capillary and rotational viscometers.
- Simplified calibration when measuring the viscosity near 1 mPa·s (Only for the SV-1A/1H/10A/10H)  
Simplified calibration using purified water is a one-key operation. The SV-1A/1H/10A/10H has a built-in function to measure the temperature of the purified water using the temperature sensor and calculates the viscosity value of the purified water at that temperature. At this time, be careful not to influence the viscosity value by generating bubbles.
- Standard windows communication tools WinCT-Viscosity (With the SV-A series, it is standard accessory. With the SV-H series, it is sold separately (AX-SV-53-EX))  
Windows communication tools WinCT-Viscosity (CD-ROM) is provided as standard. The CD-ROM contains the graphing program RsVisco, which imports the data into a personal computer and displays the results as a graph in real time. With RsVisco, changes in viscosity over time and temperature dependency of viscosity can be observed easily and the obtained data can be saved in files.
- When using the accessory serial-USB converter, the personal computer can receive the data using the personal computer's USB port. (With the SV-A series, it is standard accessory. With the SV-H series, it is sold separately (AX-SV-53-EX))
- Besides plastic sample cups, glass sample cups are available to measure organic solvents.
- Use the carrying case only for carrying the viscometer. Do not transport the viscometer using the carrying case. Doing so may cause damage to the viscometer. When transporting the viscometer, be sure to use the original packing material.



## 2. UNPACKING THE VISCOMETER

- The viscometer is a precision instrument. Unpack the viscometer carefully. Keep the packing material to be used for transporting the viscometer in the future.

### 2-1 Part Names for the SV-A Series (Stand type)

\* The illustration below is after assembling.

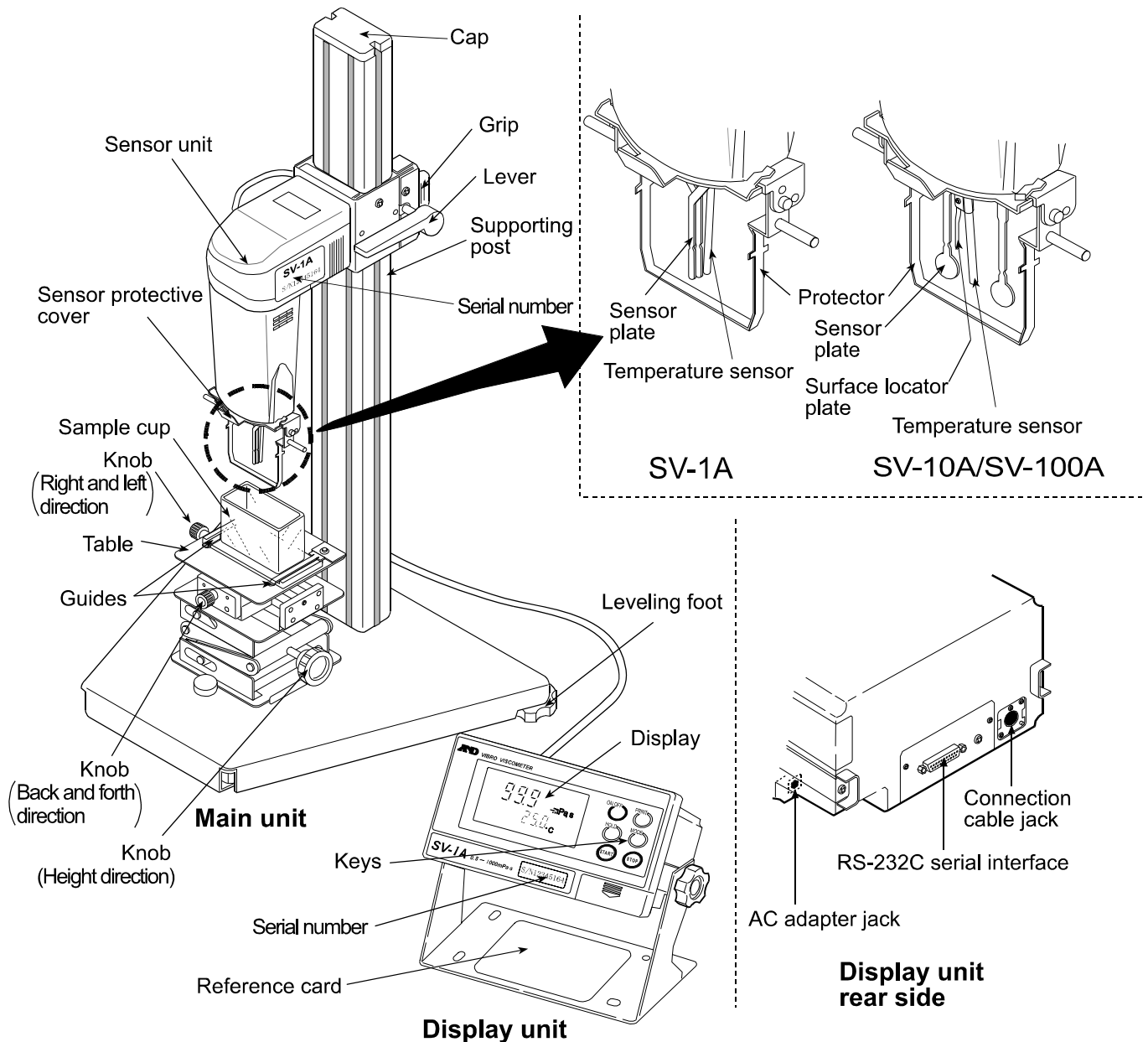

## Accessories for the SV-1A

Connection cable (1 pc) AC adapter (1 pc) AC adapter label

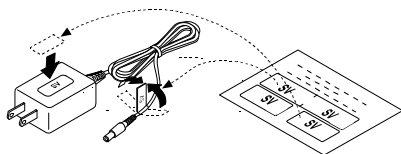
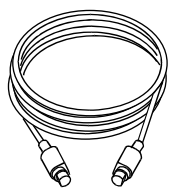

See the note below.

Square glass sample cup  
(10 mm x 10 mm x 45 mm)

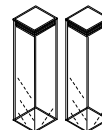

Can be used for  
optical measuring devices

Sample cup (Lid attached)  
(Polycarbonate,  
Capacity: 2 mL, 10 pcs)

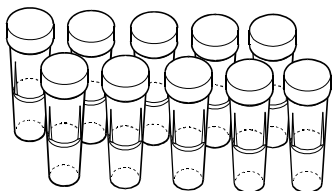

Glass sample cup  
(Capacity: 2 mL, 10 pcs)

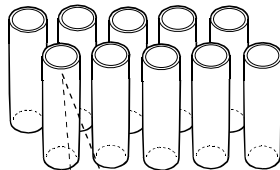

\* The lid for the sample cup  
(2 mL) does not fit this cup

Sample cup holder  
(Polycarbonate, For 2 mL capacity,  
Transparent: 3 pcs, Black: 2 pcs)

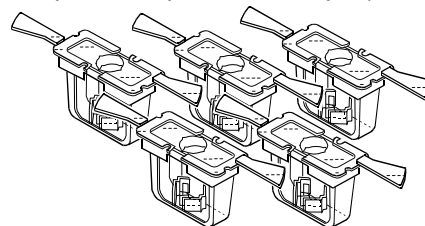

Sample cup  
(Polycarbonate  
Capacity: 45 mL, 5 pcs)

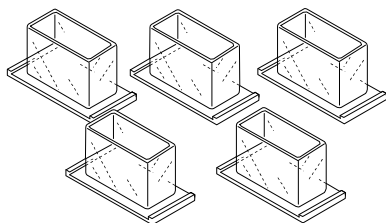

Disposable cup  
(Polyethylene terephthalate  
Capacity: 10 mL, 5 pcs)

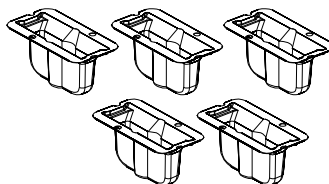

Sample cup stand  
(For 2 mL capacity, 1 pc)

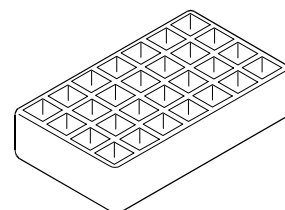

Water jacket (1 pc)

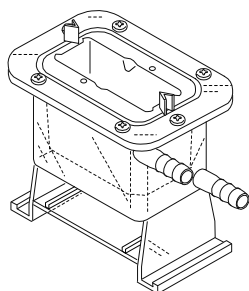

Windows communication tools  
WinCT-Viscosity(CD-ROM) (1 pc)

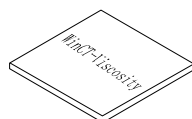

RS-232C cable (1 pc)  
25P-9P for modem

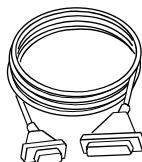

Serial-USB converter (1 pc)

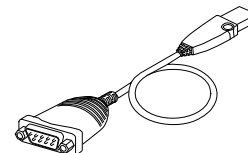

### Note

Please confirm that the AC adapter type is correct for  
your local voltage and receptacle type.

Stand for securing the sensor unit (1 pc)  
Positioning stopper (1 pc)

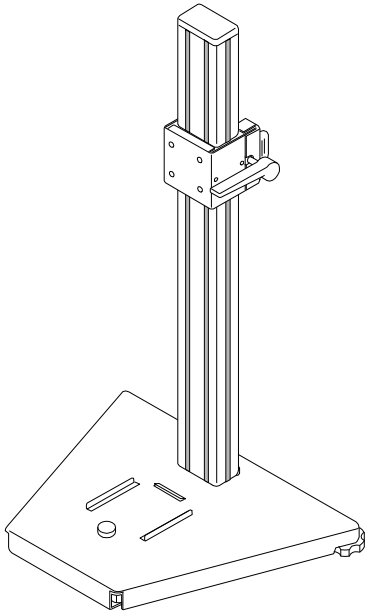

X-Y-Z stage (1 pc)

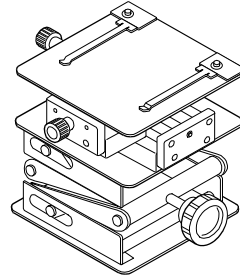

---

Dust cover for the main unit

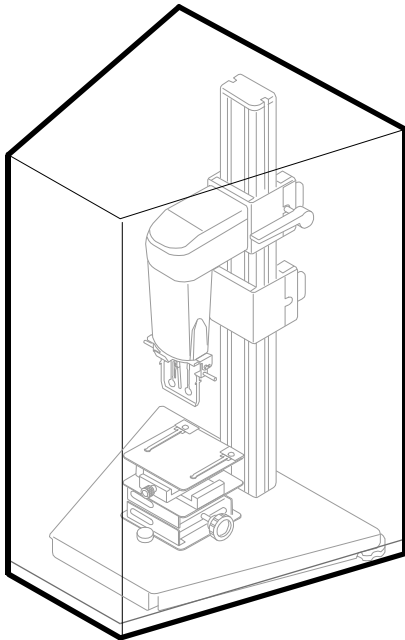

Dust cover for the display unit

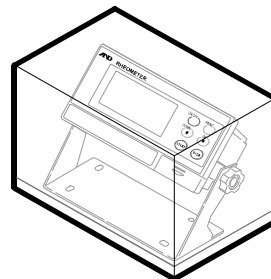

# Accessories for the SV-10A / SV-100A

Connection cable (1 pc)    AC adapter (1 pc)    AC adapter label

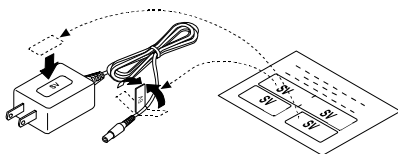
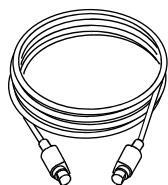

**Note**  
Please confirm that the AC adapter type is correct for your local voltage and receptacle type.

Sample cup  
(Polycarbonate,  
Capacity: 45 mL, 5 pcs)

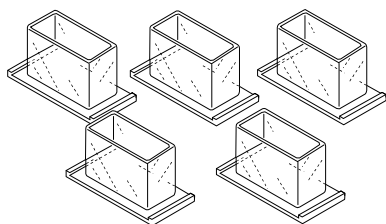

Small sample cup  
(Polycarbonate,  
Capacity: 10 mL, 5 pcs)

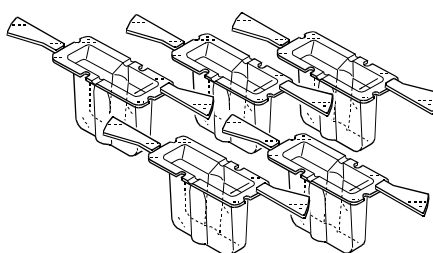

Small sample cup cover  
(Polycarbonate, 5 pcs)

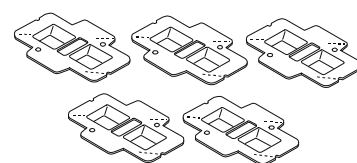

Glass sample cup  
(Capacity: 13 mL, 2 pcs)

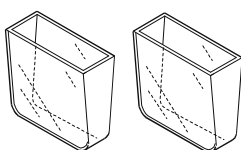

The position about 25 mm above the cup bottom indicates 13 mL.

Glass sample cup holder  
(1 pc)

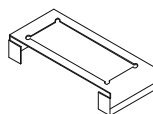

Disposable cup  
(Polyethylene terephthalate  
Capacity: 10 mL, 5 pcs)

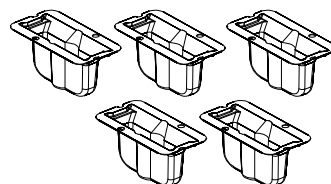

Water jacket (1 pc)

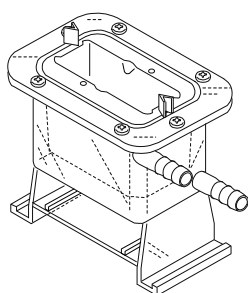

Windows communication tools  
WinCT-Viscosity(CD-ROM) (1 pc)

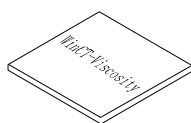

RS-232C cable (1 pc)  
25P-9P for modem

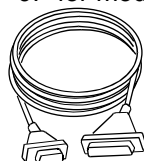

Serial-USB converter (1 pc)

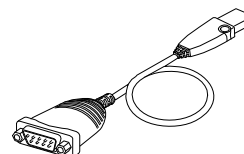

Stand for securing the sensor unit (1 pc)  
Positioning stopper (1 pc)

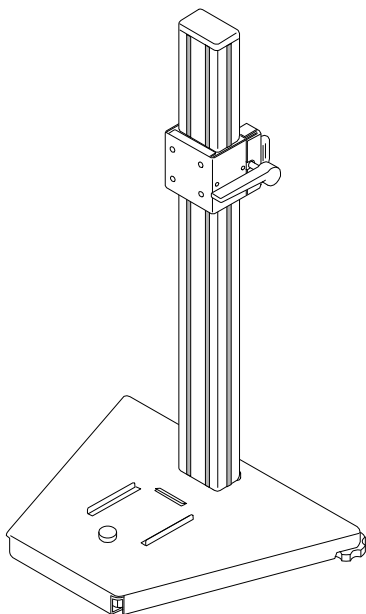

X-Y-Z stage (1 pc)

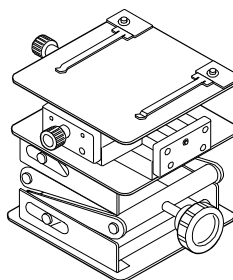

---

Dust cover for the main unit

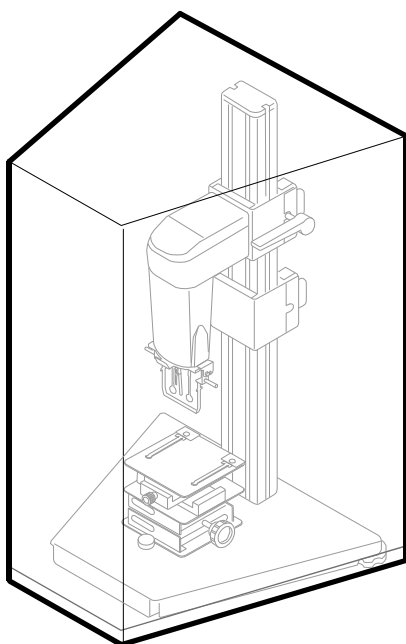

Dust cover for the display unit

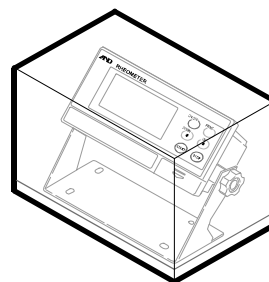

# Assembling

**Note:** When assembling, handle the sensor plates with care.

- 1 Remove the attachment screw from the base. Install the X-Y-Z stage along the guide ribs from forward of the base. Secure the X-Y-Z stage using the screw removed. (Confirm the direction of the X-Y-Z stage's knobs.)

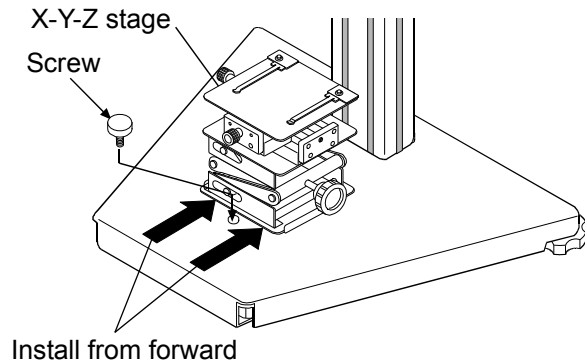

- 2 Connect the display unit to the main unit using the connection cable.

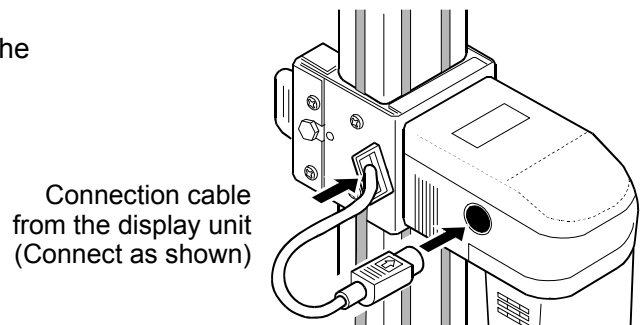

- 3 Insert the AC adapter plug into the AC adapter jack located on the rear side of the display unit. Insert the other end of the AC adapter plug into an electrical outlet.

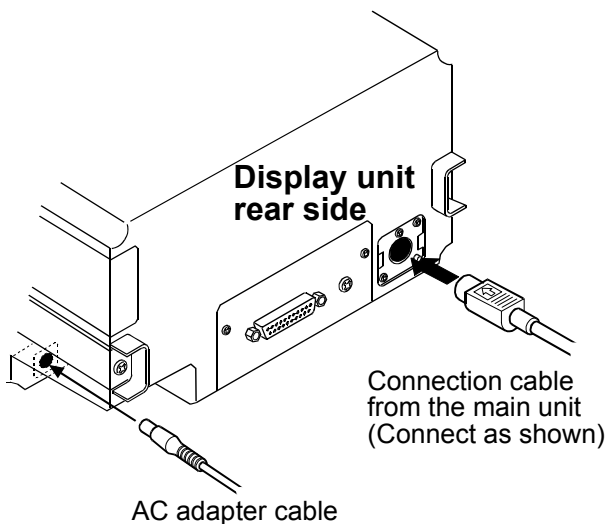
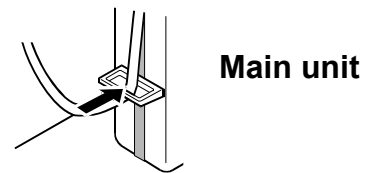

**Note:**

- Confirm that the adapter type is correct for the local voltage and power receptacle type.
- The main unit and the display unit have been adjusted in pairs. For accurate viscosity measurement, before use, confirm that the main unit and the display unit have the same serial number.

## 2-2 Part Names for the SV-H Series (Portable type)

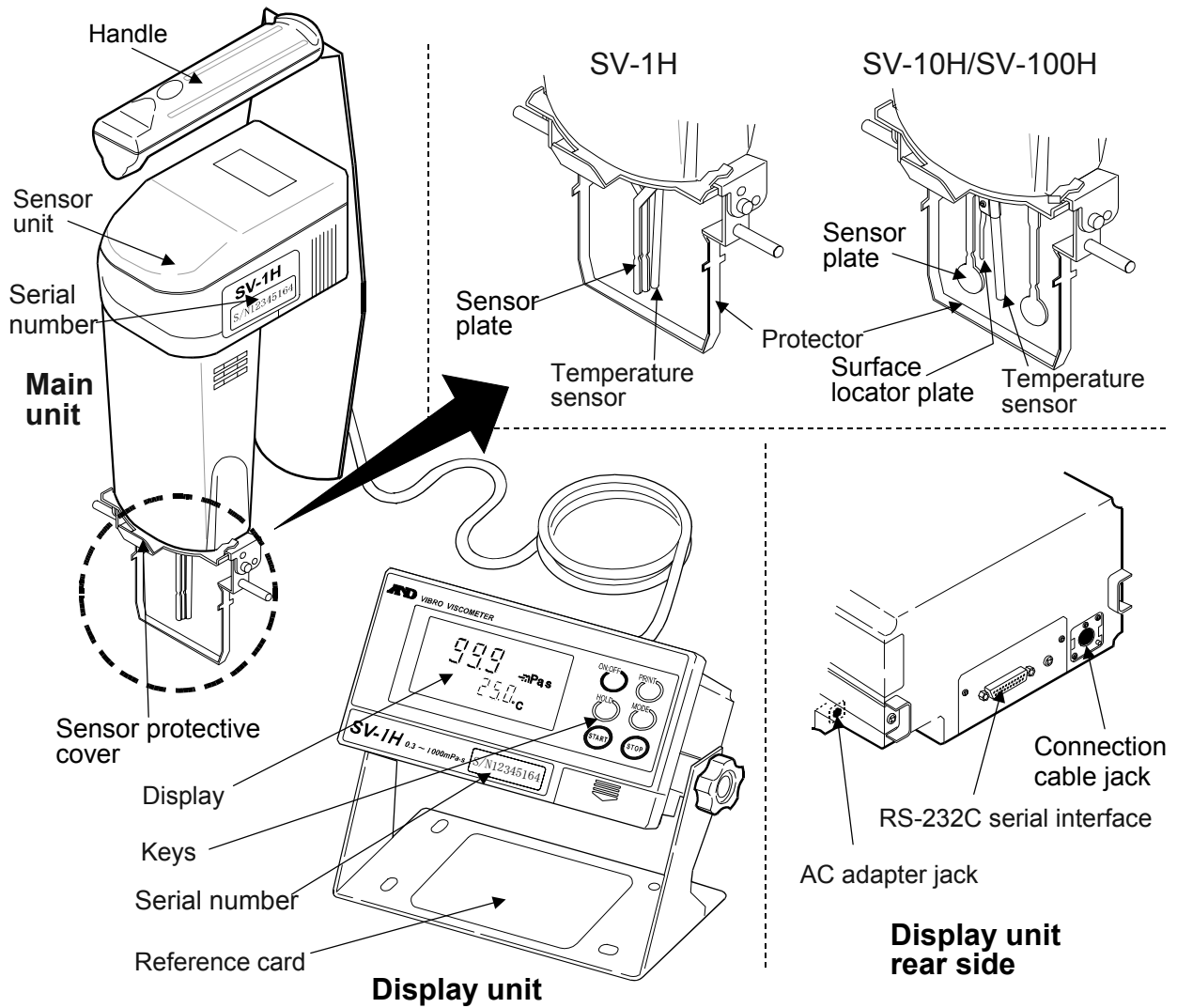

### Accessories



Connection cable (1 pc)

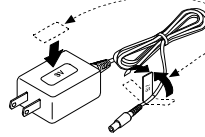

AC adapter (1 pc)

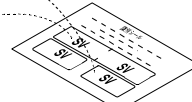

AC adapter label

#### Note

Please confirm that the AC adapter type is correct for your local voltage and receptacle type.

# Unpacking / Assembling

**Note:** When assembling, handle the sensor plates with care.

- 1 Unpack the parts from the carrying case.

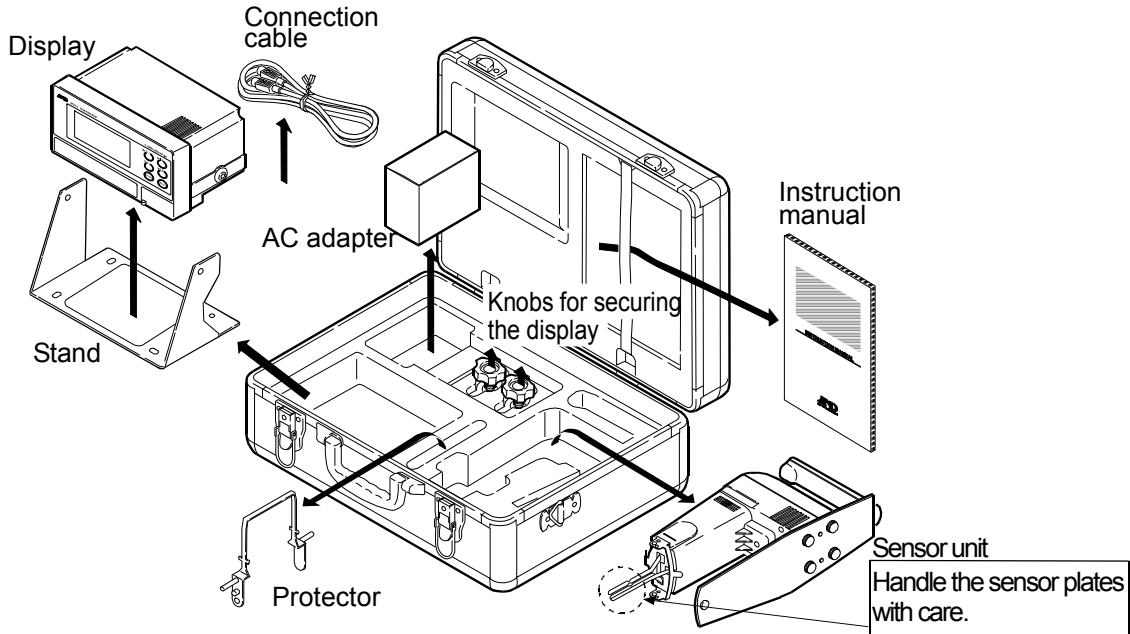

- 2 Install the protector on the sensor unit of the SV-1H/SV-10H/SV-100H. Insert the protector's rotational axes into the sensor unit's holes. (Refer to the figure at the right.)

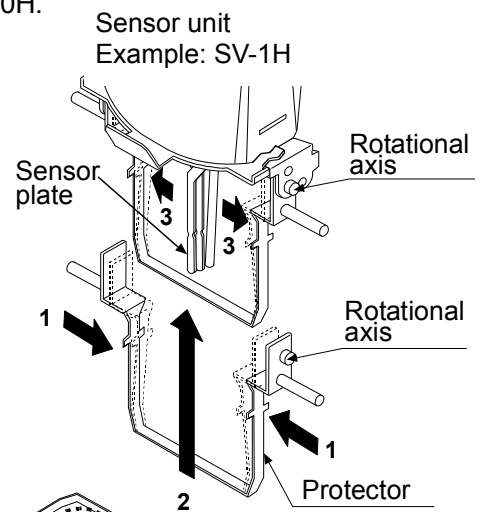

- 3 Connect the display unit to the main unit using the connection cable.

**Note**

The main unit and the display unit have been adjusted in pairs. For accurate viscosity measurement, before use, confirm that the main unit and the display unit have the same serial number.

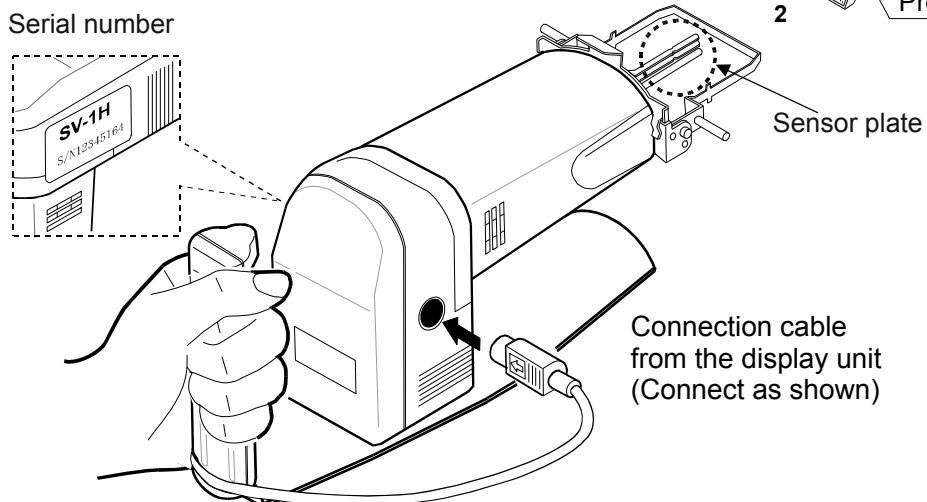



- 4 Confirm that the stand's mounting holes and the display's mounting holes are aligned. Secure both sides of the display with the knobs.

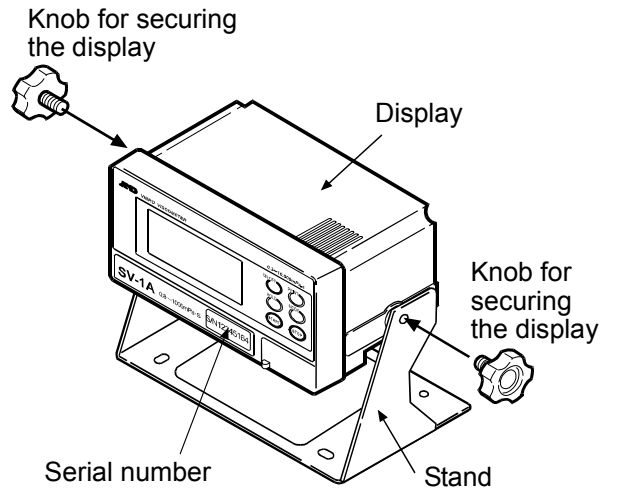

- 5 Insert the AC adapter plug into the AC adapter jack located on the rear side of the display unit. Insert the other end of the AC adapter plug into an electrical outlet.

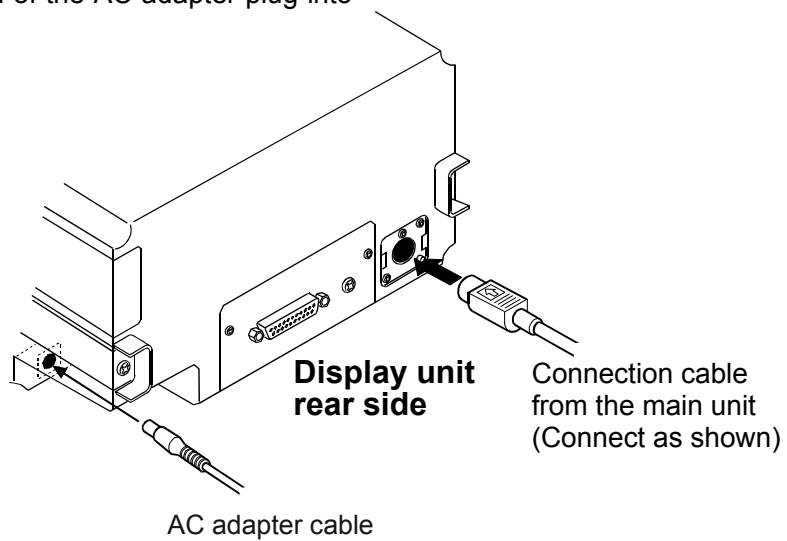

**Note**

**Confirm that the adapter type is correct for the local voltage and power receptacle type.**

# 3. CHANGING TYPES

## 3-1 Changing from the SV-H (Portable type) to the SV-A (Stand type)

In the case that you have purchased an SV-H series (portable type), and you need to use it with the stand set, prepare the following accessories and make the following changes.

- AX-SV-51 Stand set
- AX-SV-53-EX Software set
- AX-SV-54 Sample cup set (10 mL/13 mL/45 mL)
- AX-SV-55 Sample cup set (2 mL) Only for the SV-1A/SV-1H

**Note: When removing or tightening the screws located on the rear side of the sensor unit's handle, use the screwdriver that is provided with the viscometer.**

- 1 Remove the two screws from the bottom of the supporting post. Install the supporting post of the stand set onto the base. From the underside of the base, secure the post using the two screws previously removed.

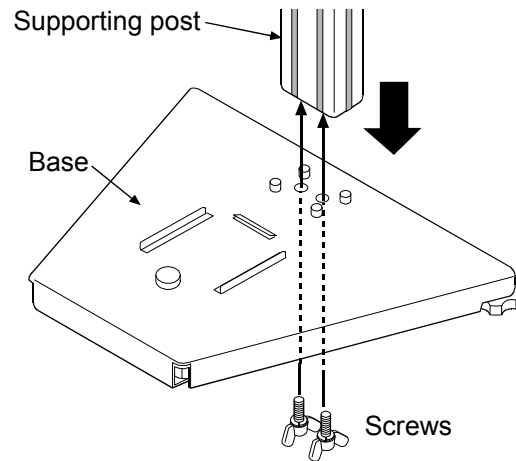

- 2 Remove the attachment screw from the base. Install the X-Y-Z stage along the guide ribs from forward of the base. Secure the X-Y-Z stage using the screw removed. (Confirm the direction of the X-Y-Z stage's knobs.)

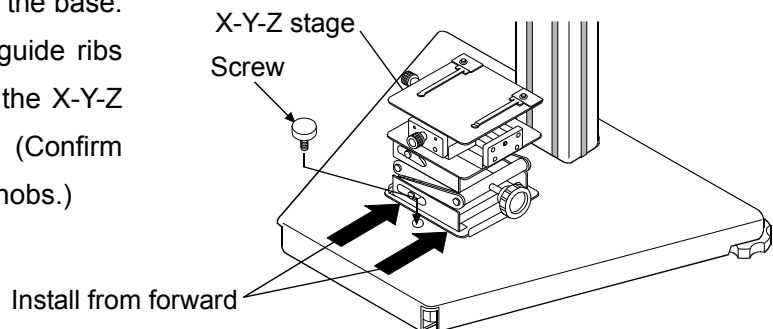

- 3 Remove the four screws from the rear side of the sensor unit's handle.  
Using the four screws removed, attach the sensor unit to the slider.

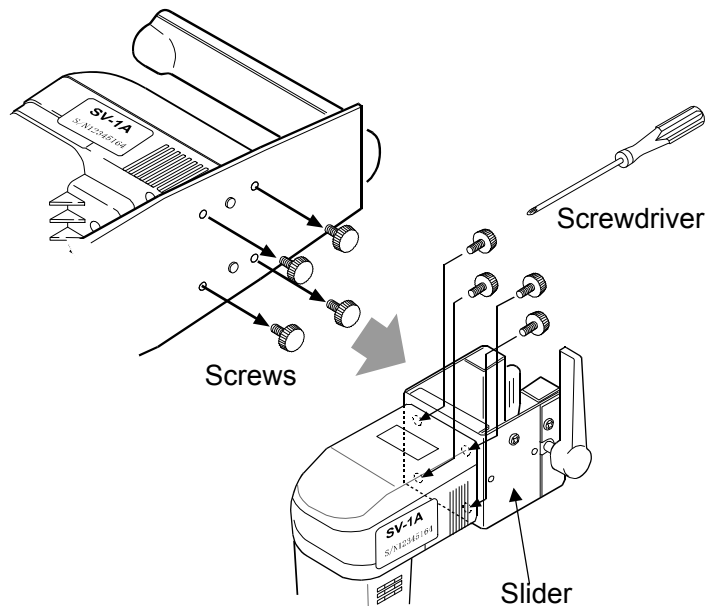

- 4 Raise the lever and install the sensor unit along the guide channels of the supporting post's sides.  
At an appropriate height, secure the sensor unit to the supporting post by lowering the lever.

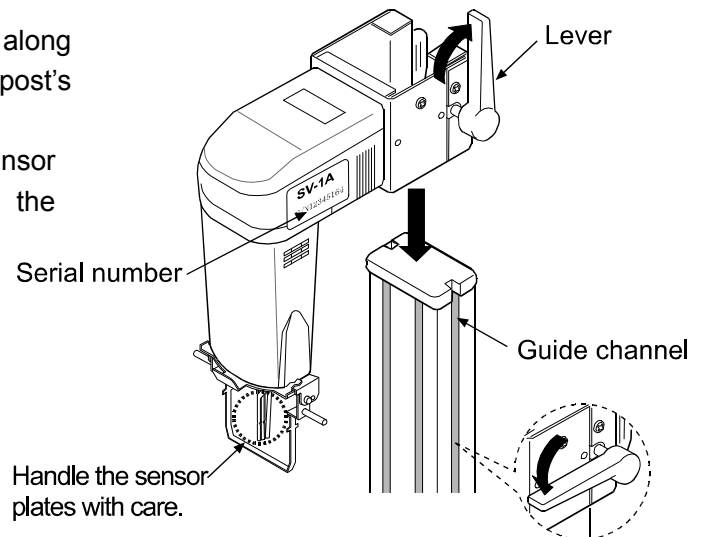

Change the function setting of "S $\bar{U}$ LTYPE" from "H $\bar{L}$ TYPE" to "A $\bar{L}$ TYPE" as follows:

\* Even if the setting of "S $\bar{U}$ LTYPE" is not changed, you can still use the viscometer. However, the portable functions, *H-Fnc*, *St-b*, *HLd-t*, *CP*, *bEP*, *CP H<sub>1</sub>* and *CP L<sub>0</sub>* remain available.

- 5 Insert the AC adapter plug into the AC adapter jack located on the rear side of the display unit.  
Insert the other end of the AC adapter plug into an electrical outlet.

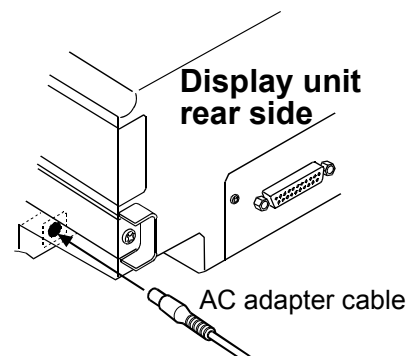

6 Press the **ON:OFF** key to turn the power on.

7 While in the standby mode, press and hold the **MODE** key for two or more seconds. The viscometer will enter the function mode **SuTYP**.

8 Press the **PRINT** key to select the item.

9 Press the **START** or **HOLD** key to display **ALYPE**.

10 Press the **PRINT** key to store the setting. After the viscometer displays **End**, it displays the next item of the function setting.

11 Press the **STOP** key to return to the standby mode.

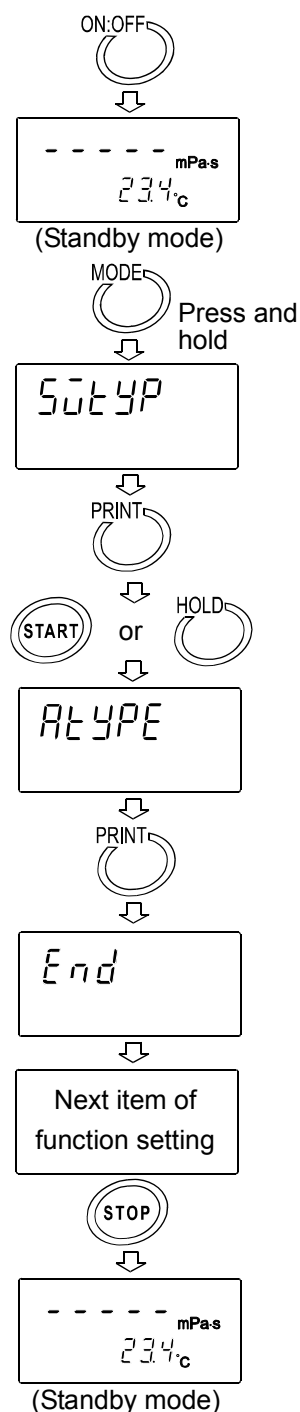

Now the portable functions *H-Fnc*, *St-b*, *HLd-t*, *CP*, *bEP*, *CP H<sub>1</sub>*, *CP L<sub>0</sub>* are not available.

# 4. DISPLAY AND KEYS

## 4-1 Display

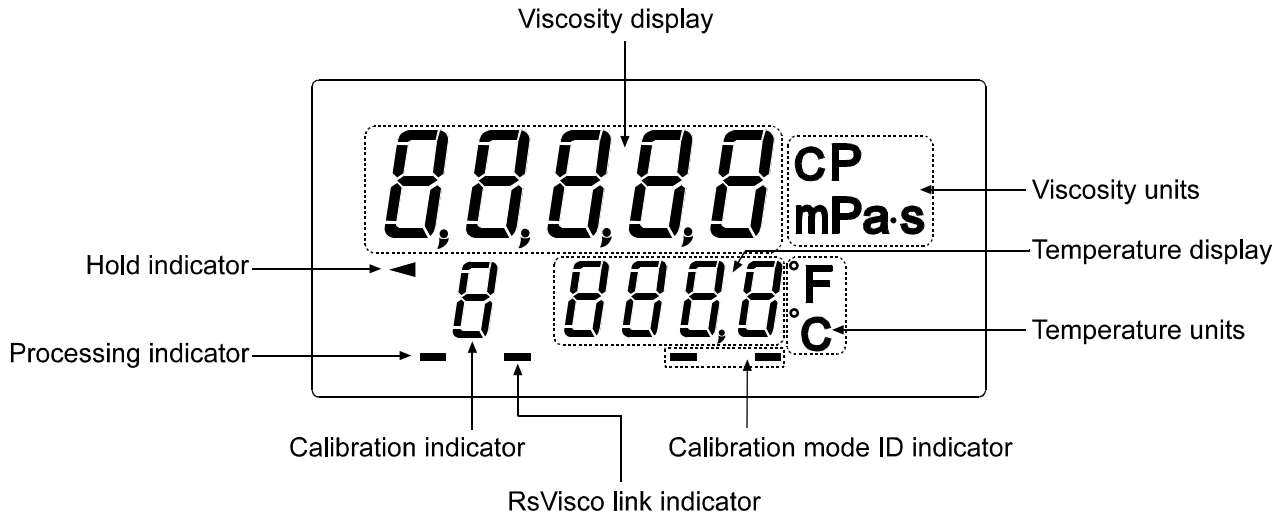

Name	Description		
Viscosity display	Standby mode	Displays [ - - - - ].	
	Measurement mode	Displays the viscosity value in real time.	
	Data hold mode	Freezes the display of the viscosity value.	
Viscosity units	Displays the unit of viscosity.		
Temperature display	Standby mode	Displays the temperature value in real time.	
	Measurement mode		
	Data hold mode	Freezes the display of the temperature value.	
Temperature units	Displays the unit of temperature.		
Processing indicator	Blinks while the measurement is being performed. (While the sensor plates are in vibrating motion)		
Hold indicator	Illuminates while the viscometer is in the data hold mode.		
RsVisco link indicator	Illuminates while measurement is performed using RsVisco, the graphing program contained in the WinCT-Viscosity (CD-ROM).		
Calibration indicator	Displays " [ " in the calibration mode.		
Calibration mode ID indicator	At one-point calibration	Blank display [ ]	
	At two-point calibration	Inputting first point	Displays [ - ].
		Inputting second point	Displays [ - - ].

## 4-2 Keys (For all models)

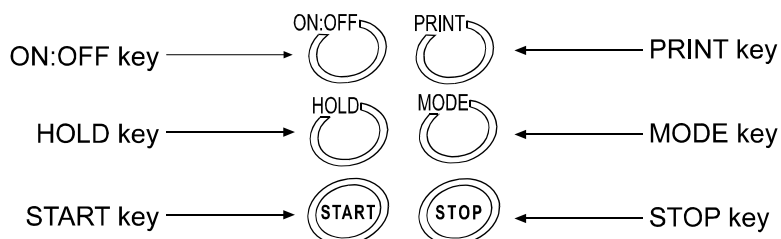

Key	Description
<b>ON:OFF</b> Power	Turns the power on and off. When the power is turned on, the viscometer enters the standby mode ([- - - -] is displayed.)
<b>START</b> Start measurement	Start a measurement. (The processing indicator blinks.) Displays the viscosity and temperature values in real time during measurement. If the display is set to HOLD, release it by pressing the <b>START</b> key.
<b>STOP</b> Stop measurement	Stops the measurement (The processing indicator is off) and freezes the display of the viscosity and temperature values at the time the <b>STOP</b> key is pressed during measurement. When the <b>STOP</b> key is pressed again, the viscometer enters the standby mode.
<b>HOLD</b> Data hold	Freezes temporarily the display of the measurement data (viscosity and temperature) at the time the <b>HOLD</b> key is pressed during measurement. (The hold indicator is on.) In the above condition, the measurement is continued. (The processing indicator blinks.) Pressing the <b>HOLD</b> key again releases the data hold mode. *1
<b>MODE</b> Change units	Changes viscosity units. *2 (By the function setting "Fnc I", the measurement elapsed time can be displayed.)
<b>PRINT</b> Output data	Outputs the measurement data.

\*1 While data are being output continuously (function setting "Print 2" or SIR command), the data hold mode using the **HOLD** key is not available.

\*2 While the measurement is being performed using the graphing program RsVisco, the data hold mode using the **HOLD** key and unit changes using the **MODE** key are not available. RsVisco is contained in the Windows communication tools of the CD-ROM, WinCT-Viscosity.

With the SV-A series, the CD-ROM is a standard accessory.

With the SV-H series, use the AX-SV-53-EX (software set, sold separately).

## 4-3 Displaying the Viscosity Values

The viscosity values are displayed as below, depending on the unit selected and the viscosity range.

The correlation of the units are as follows: 1 mPas = 0.001 Pas = 1 cP = 0.01 P

### SV-1A/SV-1H

Use the MODE key to switch between mPas (Millipascal second) and Pas (Pascal second), or between cP (Centipoise) and P (Poise).

The unit selected at the factory before shipment is mPas.

When the viscosity unit is mPas or Pas:

Viscosity measured	Unit selected							
	mPas				Pas			
mPas	Display	Minimum display	Unit	Remarks	Display	Minimum display	Unit	Remarks
1	0.30	0.01	mPas		0.0003	0.0001	Pas	Digit indicating 0.01 mPas is not displayed
	1.00				0.0010			
10	9.99	0.1	mPas		0.0099	0.0001	Pas	
	10.0				0.0100			
100	99.9	1	mPas		0.0999	0.001	Pas	
	100				0.100			
1000	999	0.01	Pas	Switches to Pas	0.999	0.01	Pas	
	1.00				1.00			

When the viscosity unit is cP or P:

Viscosity measured	Unit selected							
	cP				P			
mPas	Display	Minimum display	Unit	Remarks	Display	Minimum display	Unit	Remarks
1	0.30	0.01	cP		0.0030	0.0001	P	
	1.00				0.0100			
10	9.99	0.1	cP		0.0999	0.001	P	
	10.0				0.100			
100	99.9	1	cP		0.999	0.01	P	
	100				1.00			
1000	999	0.1	P	Switches to P	9.99	0.1	P	
	10.0				10.0			

### SV-10A/SV-10H

Use the **MODE** key to switch between mPa·s (Millipascal second) and Pa·s (Pascal second), or between cP (Centipoise) and P (Poise).

The unit selected at the factory before shipment is mPa·s.

When the viscosity unit is mPa·s or Pa·s:

Viscosity measured	Unit selected							
	mPa·s				Pa·s			
	Display	Minimum display	Unit	Remarks	Display	Minimum display	Unit	Remarks
1	0.30   1.00	0.01	mPa·s		0.0003   0.0010	0.0001	Pa·s	Digit indicating 0.01 mPa·s is not displayed
10	9.99 ----- 10.0	0.1			0.0099   0.0100			
100	99.9 ----- 100	1			0.0999   0.100			
1000	999   1.00	0.01	Pa·s	Switches to Pa·s	0.999   1.00	0.01		
10000	10.00				10.00			

When the viscosity unit is cP or P:

Viscosity measured	Unit selected							
	cP				P			
	Display	Minimum display	Unit	Remarks	Display	Minimum display	Unit	Remarks
1	0.30   1.00	0.01	cP		0.0030   0.0100	0.0001	P	
10	9.99 ----- 10.0	0.1			0.0999   0.100			
100	99.9 ----- 100	1			0.999   1.00			
1000	999   1.00	0.1	P	Switches to P	9.99   10.0	0.1		
10000	100.0				100.0			

### SV-100A/SV-100H

Use the **MODE** key to switch between Pa·s (Pascal second) and P (Poise).

The unit selected at the factory before shipment is Pa·s.

Viscosity measured	Unit selected			
	Pa·s		P	
	Display	Minimum display	Display	Minimum display
1	1.00   9.99	0.01	10.0   99.9	0.1
10	10.0 ----- 99.9		100   999	
100	100.0	0.1	1000	1



## 5. PRECAUTIONS

To get the optimum performance from the viscometer and acquire accurate measurement data, note the following:

### 5-1 General Precautions (For all models)

---

For accurate measurement, use care with the following conditions.

- Install the viscometer in an environment where the temperature and humidity are not excessive. The best operating temperature is  $25^{\circ}\text{C}\pm 2^{\circ}\text{C}$  at 45-60% relative humidity.
- For precise measurement, install the viscometer where there are no great changes in temperature and humidity.
- Install the viscometer where it is free of dust.
- The viscometer uses the Tuning-fork Vibration Method. So, use much care to avoid external vibration, especially when measuring low viscosity.

Places where the viscometer is prone to vibration are:

Second or higher floor, soft ground, near busy highways or rail lines.

Avoid these places as a measuring site. If measurement is to be performed in such a place, use an anti-vibration table that is available as an option (AD-1671A).

- Do not measure where heaters or air conditioners can affect the measurement.
- Do not measure where direct sunlight can affect the measurement.
- Install the viscometer away from equipment which produces magnetic fields.
- Protect the internal parts from liquid spills and excessive dust.
- Do not disassemble the viscometer.
- When precise measurement is required, acclimatize the viscometer to the measuring environment. After installation, plug in the AC adapter and warm up the viscometer for one hour or more.

### 5-2 Precautions for an Accurate Measurement (Only for the SV-H series)

---

- With the SV-H series, when you need to make an accurate measurement, adjust the height of the sample surface and sensor plates correctly by using the AX-SV-51 stand set. The specification values are when using the stand set.

### 5-3 During Use (For all models)

---

- The SV-A/SV-H series viscometer, designed for very accurate measurement, is sensitive to vibration or shock during transportation, as that may cause a display value error. Before measurement, calibrate the viscometer using the sample cup that will be used for measurement.
- To level the surface of the sample, adjust the leveling feet. (Height adjustment of the right and left leveling feet.)

(With the SV-10A, both of the right and left sensor plates are on the liquid surface.)

\* With the SV-H series, use the AX-SV-51 (stand set, sold separately).

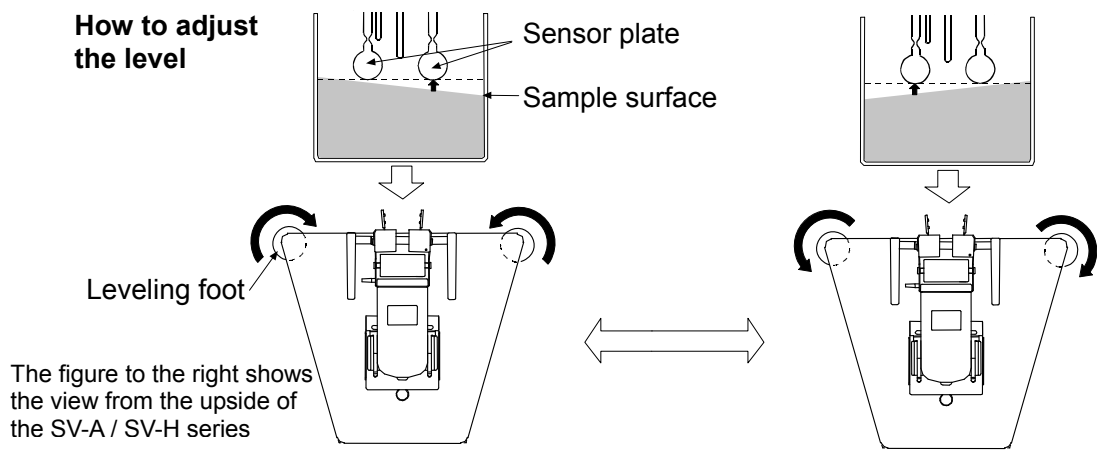

- The viscosity value of a liquid changes in accordance with the temperature change. In general, if the temperature rises, the viscosity value decreases about 2 to 10 percent per degree Celsius. Take changes in the liquid temperature into consideration for an accurate measurement.
- Be sure to calibrate using the standard viscosity fluid or purified water before measurement. In a measurement that takes a long time, perform calibration periodically, as necessary.
- Ensure a stable power source when using the AC adapter.
- Placing the sensor plates and the temperature sensor in the sample may change the sample temperature. For precise measurement, leave the sample as is for a while, after placing the sensor plates and the temperature sensor, to ensure no changes to the sample temperature. And then, start a measurement.
- Use only your finger to press the keys. Using a sharp instrument such as a pen may damage keys.
- Handle the sensor plates with care.
- If the sensor plates, or the protector, touch the inner wall of the sample cup, it may cause measurement error. When measuring, be sure to adjust the spacing between the sensor plates and the inner wall of the sample cup.
- The sample cups are made of polycarbonate (PC) or glass. When using organic solvents, we recommend the use of the glass sample cup (accessory or sold separately) or a commercially available glass beaker.
- Raise or remove the protector if necessary.

**How to remove the protector:**

Press the left and right side frames lightly in the direction indicated as 1 to release the rotational axes. Pull the protector in the direction indicated as 2 to remove.

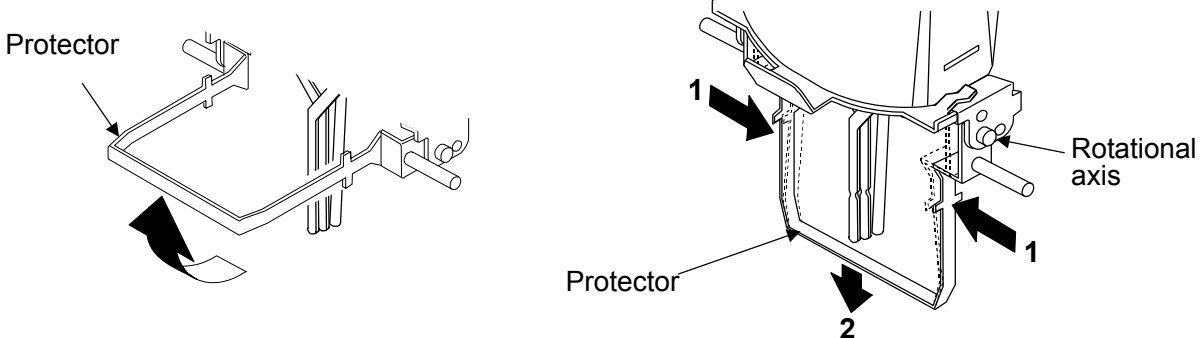

## 5-4 After Use (For all models)

- Remove any residual sample material from the sensor plates, temperature sensor and protector using alcohol. Using the sensor plates, temperature sensor and protector with residue of an old sample left on will cause a measurement error. Clean the sensor plates carefully to avoid bending them. The sensor plates and the temperature sensor are made of titanium.

### How to clean the sensor plates and temperature sensor

#### SV-1A/SH-1H

Hold the sensor plates with folded tissue paper. Move the tissue paper upward and downward to remove the sample. Pushing strongly on the sensor plates when moving the tissue upward, may cause the sensor plates to bend.

Clean the temperature sensor in the same way.

Then, use tissue paper moistened with alcohol, to remove any residual sample material.

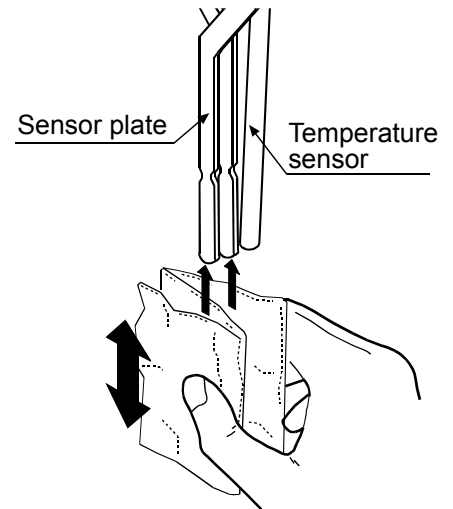

#### SV-10A/SV-10H/SV-100A/SV-100H

Hold the sensor plate or temperature sensor with tissue paper. Move the tissue paper downward to remove the sample.

Then, use tissue paper moistened with alcohol, to remove any residual sample material.

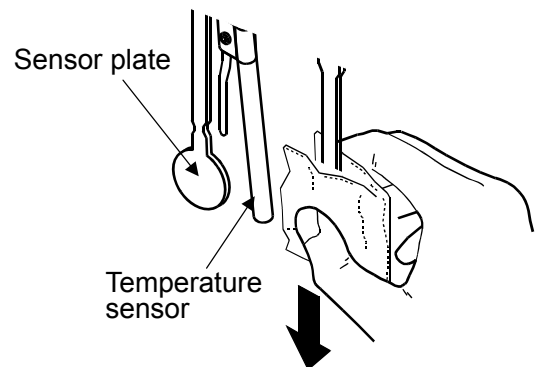

- Clean the sample cup as necessary.
- Unlock the cable connector before disconnecting the connection the cable.

### How to unlock the cable connector

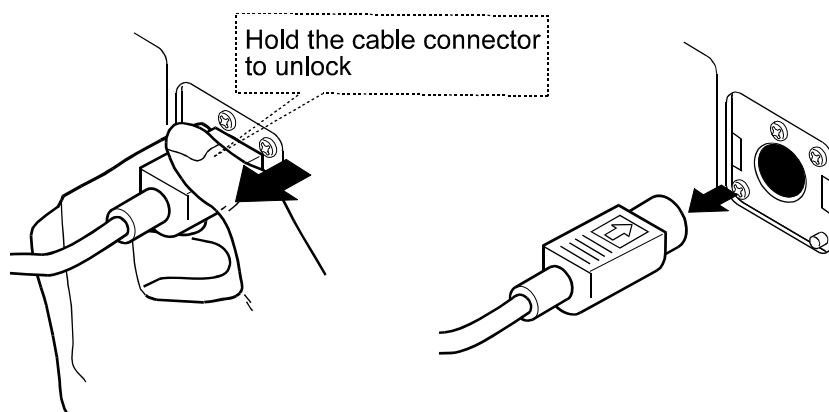

## Storing the viscometer

Use the dust cover to protect the viscometer from dust and dirt during storage.

- Place the viscometer where it is free of dust.
- The dust cover can be used while the viscometer is connected to the AC adapter and other cables.
- When removing the dust cover, take care not to get its edge caught on the viscometer.
- Specifications
  - Material: Nylon
  - Color: Light gray

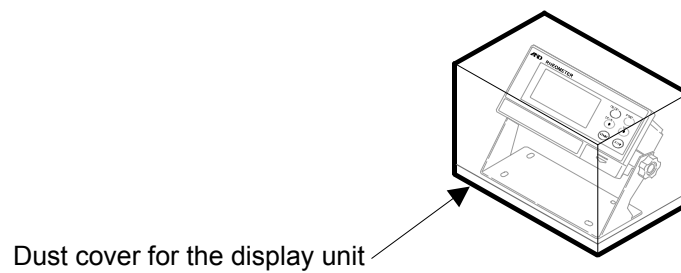
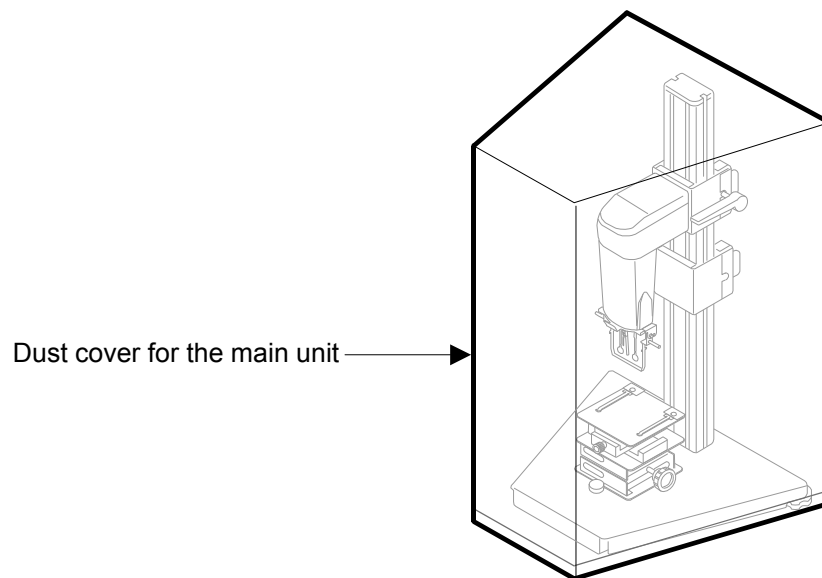

## 5-5 About Viscosity Measured (For all models)

---

The SV-A/SV-H Series Sine-wave Vibro Viscometer, as a measuring principle, detects the product of viscosity and density (defined as “static viscosity”).

$$\text{Static viscosity} = \text{Viscosity} \times \text{Density} \dots \dots [1]$$

While the displayed value has a unit of mPa·s, it indicates the product of viscosity and density.

**Example** (1) When a sample has a viscosity of 2.00 mPa·s and density of 1.000:

$$\begin{aligned} \text{Displayed value} &= 2.00 \text{ [mPa}\cdot\text{s]} \times 1.000 \\ &= 2.00 \text{ [mPa}\cdot\text{s]} \end{aligned}$$

(2) When a sample has a viscosity of 2.00 mPa·s and density of 0.800:

$$\begin{aligned} \text{Displayed value} &= 2.00 \text{ [mPa}\cdot\text{s]} \times 0.800 \\ &= 1.60 \text{ [mPa}\cdot\text{s]} \end{aligned}$$

### Note

**The density can be measured, using the density determination kit, AD-1653 in combination with a balance.**

To obtain the absolute viscosity value precisely, do as follows:

### At measurement

Divide the static viscosity by the sample density to obtain the viscosity.

**Example** (1) Measure the sample and confirm the static viscosity.

Here, 736 mPa·s as an example.

(2) Check the sample density at the temperature when the sample is measured.

Here, 0.856 as an example.

(3) Divide the static viscosity by the sample density to obtain the viscosity.

Here, 860 mPa·s is obtained as the viscosity.

$$\begin{aligned} \text{Viscosity} &= \frac{\text{Static viscosity}}{\text{Sample density}} \\ &= \frac{736}{0.856} \cong 860 \text{ mPa}\cdot\text{s} \end{aligned}$$

## At calibration

When calibrating, enter the product of the absolute viscosity value and the density of the standard viscosity fluid used for calibration, as a correction value.

The standard viscosity fluid has the calculation sheet of kinetic viscosity and viscosity at various temperatures attached. To obtain the correction value using this sheet, do as follows:

$$\text{Kinetic viscosity} = \frac{\text{Viscosity}}{\text{Density}} \quad \text{From this, Density} = \frac{\text{Viscosity}}{\text{Kinetic viscosity}} \dots [2]$$

$$\text{Correction value} = \text{Viscosity} \times \text{Density} \dots [3]$$

When substituting [2] for the density in [3], the following equation is obtained.

$$\text{Correction value} = \frac{\text{Viscosity}^2}{\text{Kinetic viscosity}} \dots [4]$$

**Example 1:** To calibrate the viscometer using a standard viscosity fluid:

Using the calculation sheet, calculate the value used for calibration.

- (1) Check the kinetic viscosity and the viscosity at the temperature when the calibration is performed.

Here, 1011 mm<sup>2</sup>/s for the kinetic viscosity and 889 mPa·s for the viscosity at 20°C as an example.

- (2) Substitute the values above into equation [4].

$$\frac{889^2}{1011} \cong 781$$

781 mPa·s is obtained as a correction value used for calibration.

- (3) After calibration, measure the viscosity of the standard viscosity fluid used. In this example, a value similar to “781 mPa·s” is confirmed as static viscosity, and calibration then ends.

**Example 2:** To calibrate using a standard viscosity fluid with known values of viscosity and density.

In this example, a standard viscosity fluid with a viscosity of 889 mPa·s at 20°C is used.

- (1) Check the viscosity value and the density of the standard viscosity fluid at the temperature when the calibration is performed..

Here, 889 mPa·s for the viscosity and 0.878 for the density at 20°C as an example.

- (2) Substitute the values above into equation [3].

$$889 \times 0.878 \cong 781$$

781 mPa·s is obtained as a correction value used for calibration.

- (3) After calibration, measure the viscosity of the standard viscosity fluid used. In this example, a value similar to “781 mPa·s” is confirmed as static viscosity, and calibration then ends.

## 6. MEASUREMENT

### 6-1 Preparing the Sample (For the SV-A series)

\* Vibration or shock during transportation may cause a display value error. Before measurement, calibrate the viscometer using the sample cup that will be used for measurement. For calibration with purified water, refer to "9-2-3 Simplified calibration using purified water". (Only for the SV-1A/10A)

#### Model: SV-1A

- 1 Pour the sample into the cup until its surface is between the level gauges.

- With the 2 mL sample cup, the lower level gauge indicates 1.8 mL, the upper level gauge indicates 2 mL.

- With the 45 mL sample cup, the lower level gauge indicates 35 mL, the upper level gauge indicates 45 mL.

\*The glass sample cup does not have level gauges.

- 2 Attach the cup on the table along the guides.

- With the 2 mL sample cup, place the sample cup in the sample cup holder (For 2 mL), and set it into the 45 mL sample cup.

- \* When using the sample cup holder, select either the transparent holder or the black holder, depending on the sample color.

- 3 Confirm that the protector is in the position as shown in the figure.

Raise the lever to release the sensor unit.

- 4 Pinch the grips, support the front side of the sensor unit and gently lower the sensor plates above the sample surface.

Adjust the X-Y-Z stage if necessary.

- 5 Lower the lever to secure the sensor unit.

- 6 Adjust the X-Y-Z stage so that the sensor plates will be positioned in the center of the sample cup.

- When using the 2 mL sample cup, raise the protector.

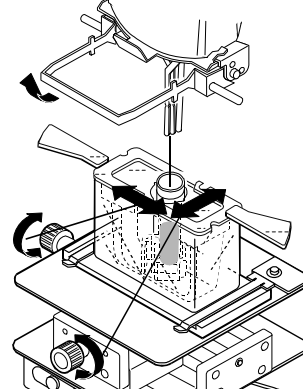
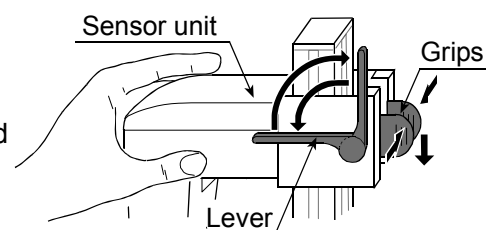
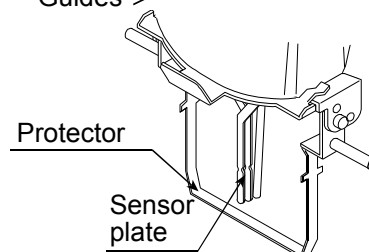
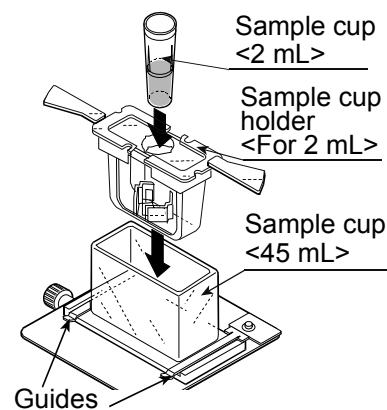
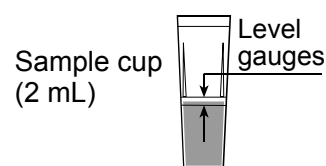

- Turn the knob (Height direction) so as to adjust the sample surface to the center of the narrow part of the sensor plates. Confirm that the sample surface is between the upper and lower triangular marks.

**Note**

- When using the 2 mL sample cup, raise the protector.
- Adjust the height of the sample surface correctly, otherwise it may cause a measurement error.

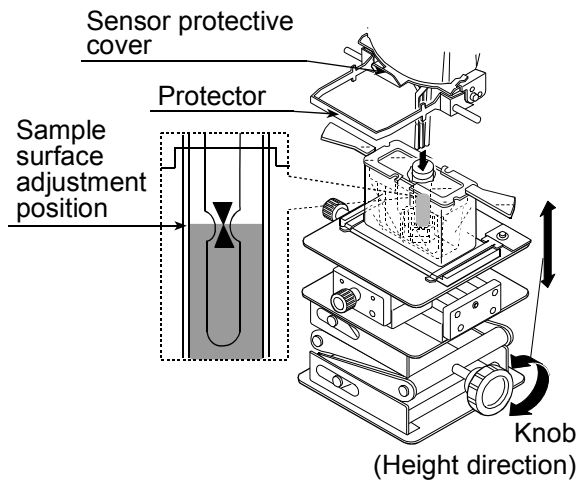

**Model: SV-10A / SV-100A**

- Pour the sample into the cup until its surface is between the level gauges.
  - With the 45 mL sample cup, the lower level gauge indicates 35 mL, the upper level gauge indicates 45 mL.
  - The 13 mL glass sample cup does not have level gauges. The position approximately 25 mm above the cup bottom indicates 13 mL.

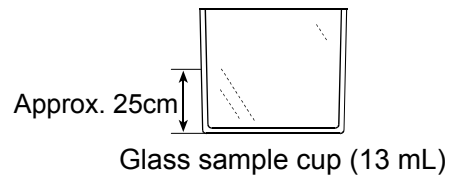
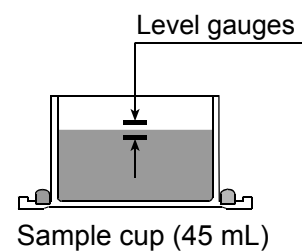

- Attach the cup on the table along the guides.

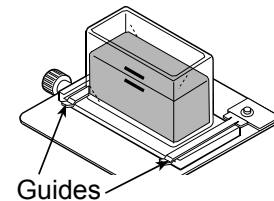

- Confirm that the protector is in the position as shown in the figure.

Raise the lever to release the sensor unit.

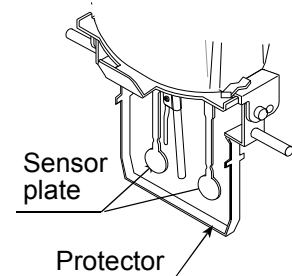

- Pinch the grips, support the front side of the sensor unit and gently lower the sensor plates above the sample surface.

- Lower the lever to secure the sensor unit.

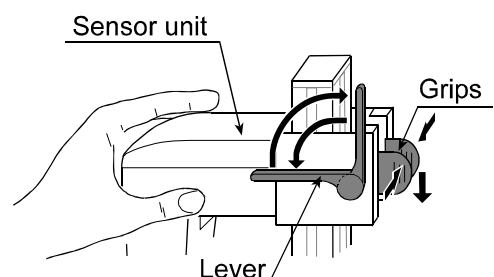



- 6 Adjust the X-Y-Z stage so that the sensor plates will be positioned in the center of the sample cup.

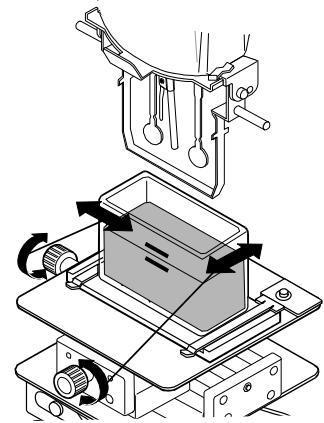

- 7 Turn the knob (Height direction) so as to adjust the sample surface to the center of the narrow part of the sensor plates. At this time, use the surface locator plate as a guide. The surface locator plate has been secured in position so that the tip of the surface locator plate comes into contact with the sample surface.

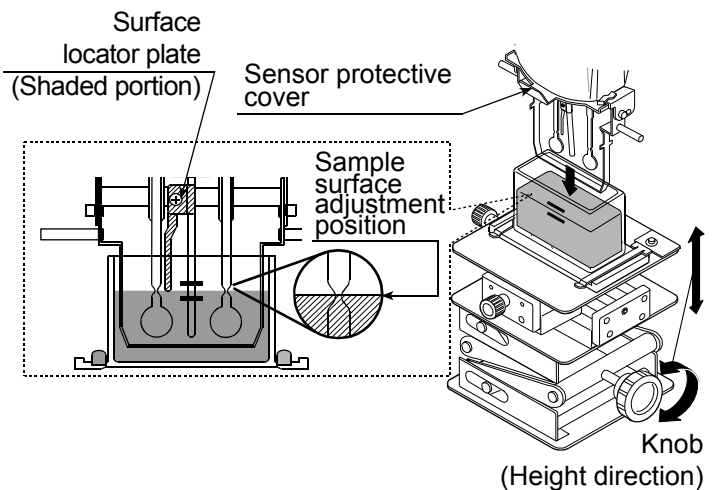

**Note**

- Adjust the height of the sample surface correctly, otherwise it may cause a measurement error.
- With the SV-10A/SV-100A, the surface locator plate can be attached or removed by loosening the screw.
- With the SV-10A/SV-100A, before removing the sensor protective cover, remove the surface locator plate.
- Removing and reattaching the surface locator plate will cause the position (Height) of the sensor plates and the sample surface to change. Therefore, it is recommended that calibration be performed using a standard viscosity fluid before measurement.

**Note**

Use the protector in the position as shown on the left below. If the protector is not used, a measurement error may occur, especially in measuring a viscosity over 5000 mPas.

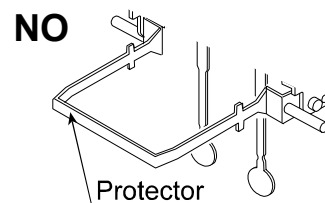
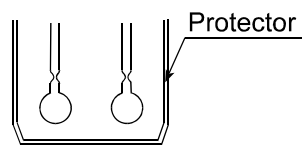

When the position of the sensor plates in the liquid is not at the same level, level the viscometer using the leveling feet so that the liquid surface will be leveled.

## 6-2 Basic Measurement Procedure (For the SV-A series)

Below is an example of the SV-10A at shipment.

- 1 With the power turned off, press the **ON:OFF** key.
- 2 When the display is in the standby mode, press the **START** key. \*1  
After about 15 seconds, the measurement values are displayed.
- 3 During measurement, press the **HOLD** key as necessary, to freeze the display temporarily.  
To release the data hold mode, press the **HOLD** or **START** key again. \*2
- 4 Press the **STOP** key to stop the measurement.  
The measurement results freeze and are displayed.
- 5 To stop the measurement, press the **STOP** key.  
To go on to the next measurement, set the sample and press the **START** key.

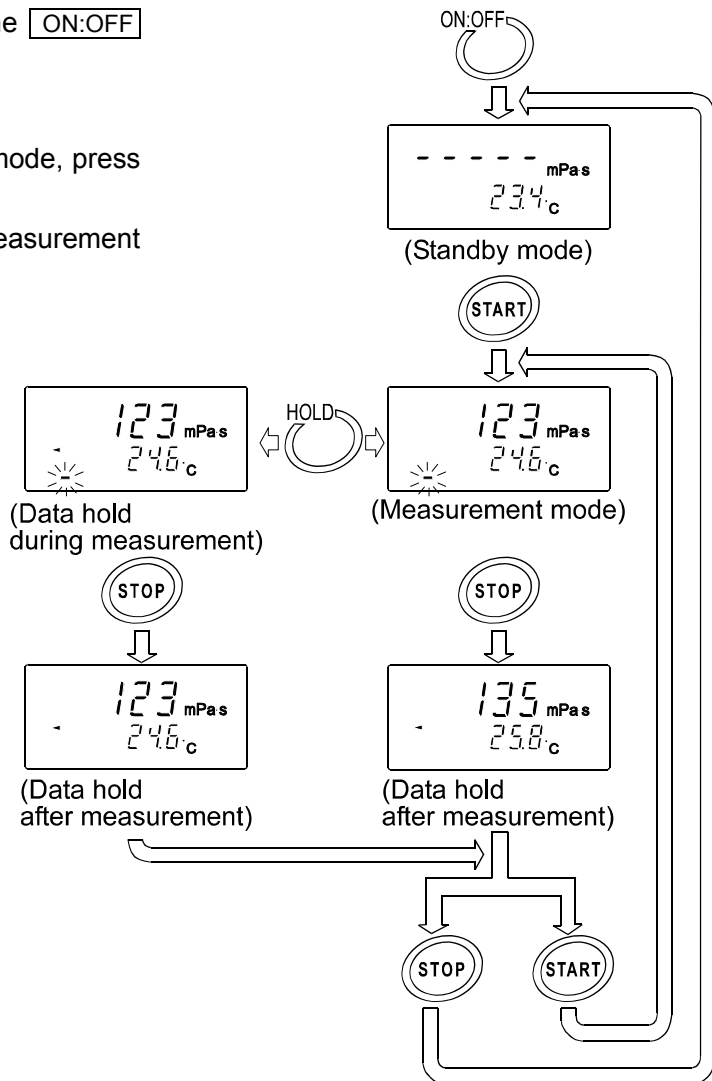

When the viscosity value is below the measuring range, **L** is displayed.

When the viscosity value exceeds the measuring range, **H** is displayed.

If the sensor plates are not in vibrating motion for about 20 seconds, for example, when the sample coagulates, the measurement will stop automatically.

- \*1 When the graphing program RsVisco is used, click the **START** button on the RsVisco to start a measurement.
- \*2 While the measurement is being performed using the graphing program RsVisco or data are being output continuously (function setting "Prt 2" or SIR command), the data hold mode using the **HOLD** key is not available.

## 6-3 Basic Measurement Procedure (For the SV-H series)

- 1 Pour the sample into the beaker (500 mL).

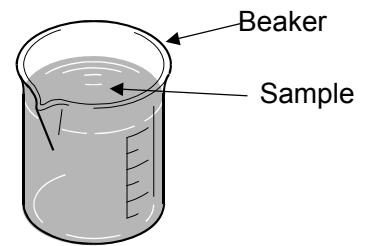

- 2 With the power turned off, press the **ON:OFF** key. When the display is in the standby mode, the SV-H can measure.

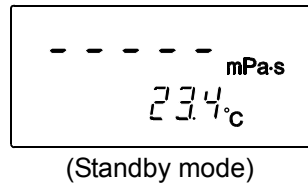

- 3 Hold the SV-H handle firmly in your hand. Prepare to insert the sensor plates into the sample.

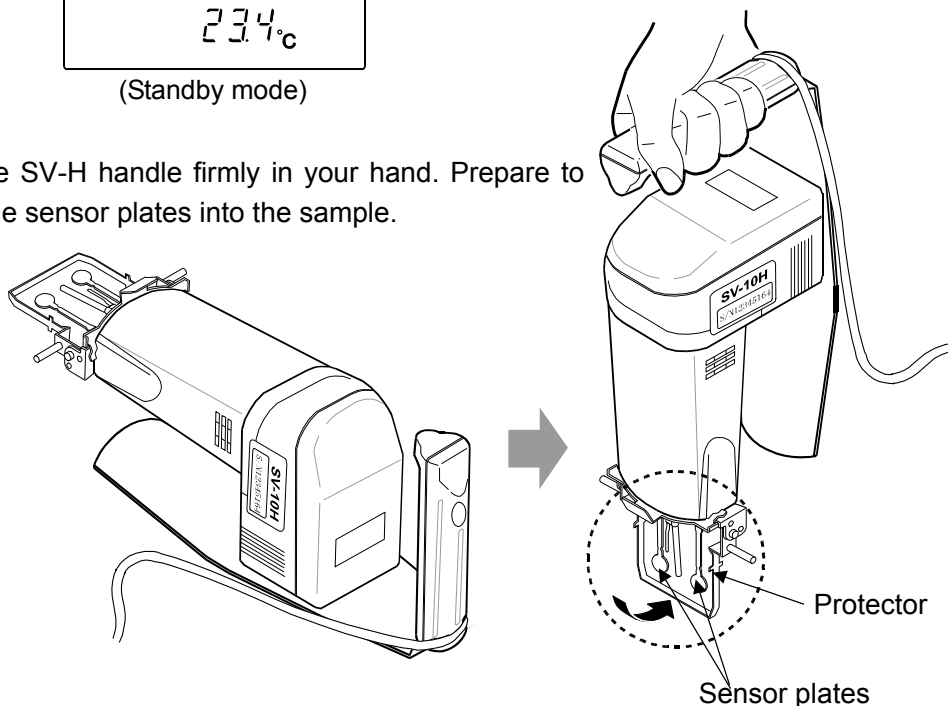

- 4 Press the **START** key. Insert the sensor plates into the sample.

The measurement time is about 15 seconds. After inserting the sensor plates into the sample, maintain the height of the sensor plates.

**L** is displayed when the sensor plates do not touch the liquid.

Immediately after the sensor plates touch the liquid, **L** will be still displayed. Continue the measurement with this state. After stabilization, the viscometer displays the viscosity value.

### [Precautions when inserting the sensor plates into the sample]

Confirm that the protector is in the position as shown in the figure, and then insert the sensor plates into the sample.

Confirm that the sample surface is the center of the narrow part of the sensor plates. Keep the SV-H at this position (Height).

At this time

- With the SV-1H, there are the triangular marks on the sensor plates. Confirm that the sample surface is between the upper and lower triangular marks.

- With the SV-10H/100H, use the surface locator plate as a guide. The surface locator plate has been secured in position so that the tip of the surface locator plate comes into contact with the sample surface.

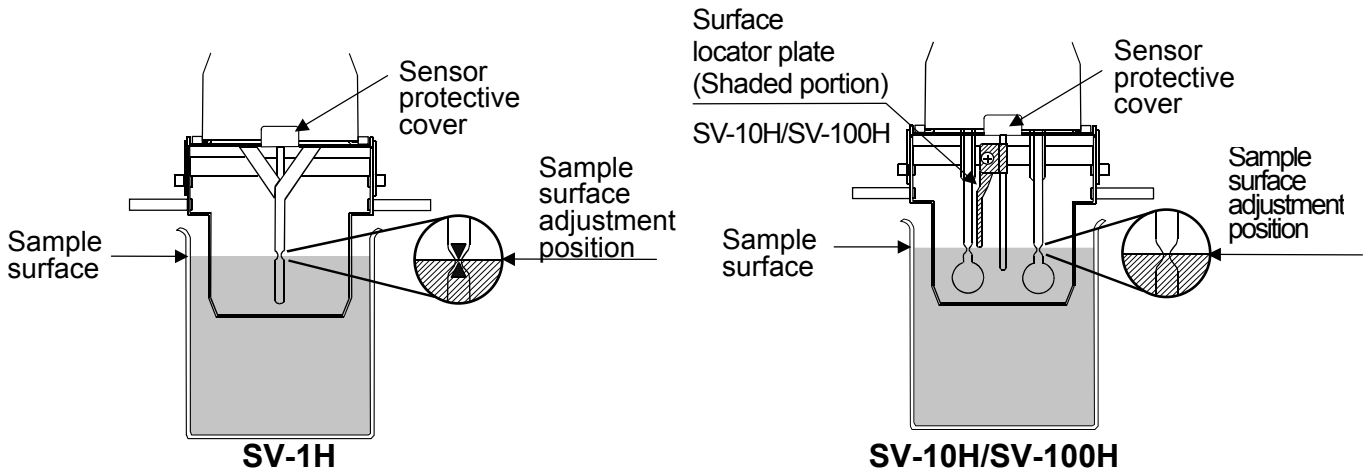

**Note**

Use the protector in the position as shown on the left below. If the protector is not used, use care so that the sensor plates do not touch the inner wall of the beaker. With the SV-10H, when the protector is removed, a measurement error may occur, especially in measuring a viscosity over 5000 mPa.s.

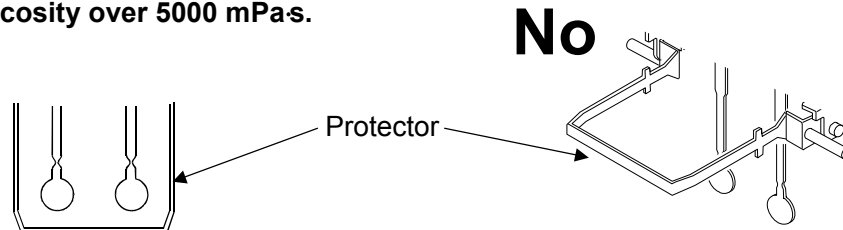

**Note**

- Adjust the height of the sample surface correctly, otherwise it may cause a measurement error.
- When you need a more accurate measurement, use the stand set (AX-SV-51, sold separately).
- With the SV-10H/SV-100H, the surface locator plate can be attached or removed by loosening the screw.
- With the SV-10H/SV-100H, before removing the sensor protective cover, remove the surface locator plate.
- Removing and reattaching the surface locator plate will cause the position (Height) of the sensor plates and the sample surface to change. Therefore, it is recommended that calibration be performed using a standard viscosity fluid before measurement.

Below is an example of the SV-10H at shipment.

- 5 After measurement, the buzzer sounds and the displayed value blinks, then freezes.

**Note**

When the values do not stabilize because of hand movement, set the condition function that levels the large variation in digits (refer to page 55) and the function that do not display the large variation in digits (refer to page 56) if necessary.

With the portable type, you can use the auto hold function and timer mode function (refer to page 58).

- 6 To stop the measurement, press the **STOP** key.  
To go on to the next measurement, set the sample and press the **START** key.

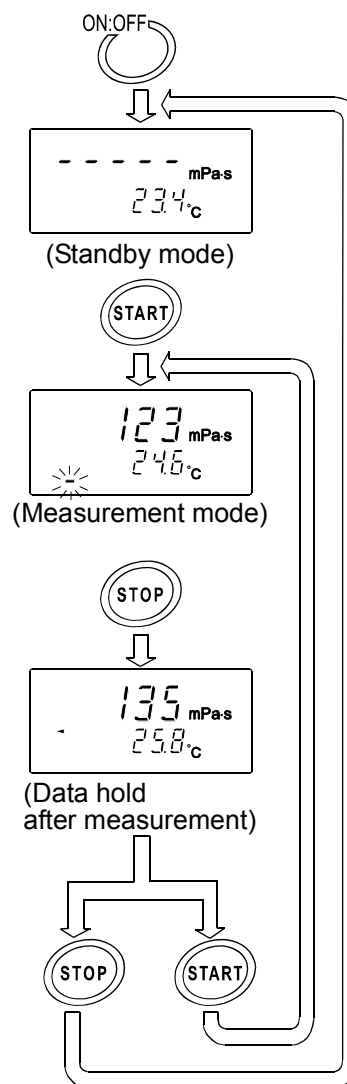

When the viscosity value is below the measuring range, **L** is displayed.

When the viscosity value exceeds the measuring range, **H** is displayed.

If the sensor plates are not in vibrating motion for about 20 seconds, for example, when the sample coagulates, the measurement will stop automatically.

- \*1 When using the graphing program RsVisco, of the AX-SV-53-EX software set, click the **START** button of the RsVisco program to start a measurement.
- \*2 While the measurement is being performed using the graphing program RsVisco of the AX-SV-53-EX software set or data are being output continuously (function setting "P r t 2" or SIR command), the data hold mode using the **HOLD** key is not available.

## 6-4 Changing Units (For all models)

The units of viscosity available are: mPa·s (millipascal second),

Pa·s (Pascal second),

cP (Centipoise),

P (Poise).

The correlation of the units are as follows: 1 mPa·s = 0.001 Pa·s = 1 cP = 0.01 P

The units of temperature available are: °C (Celsius) and °F (Fahrenheit).

The unit selected upon power-on depends on the function setting. The unit selected at the factory before shipment is as shown below.

Model	Viscosity	Temperature
SV-1A/SV-1H SV-10A/SV-10H	mPa·s	°C
SV-100A SV-100H	Pa·s	

Use the **MODE** key to change units. Each time the **MODE** key is pressed, units are switched as below:  
Note that the unit of temperature is fixed in the function setting.

### SV-1A/SV-1H/ SV-10A/SV-10H

- In the function setting, mPa·s or Pa·s is selected:

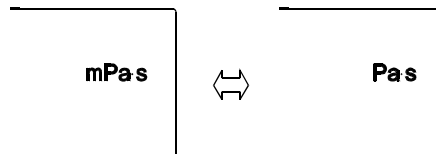

- In the function setting, cP or P is selected:

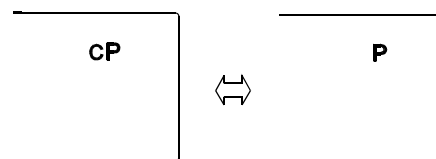

### SV-100A/SV-100H

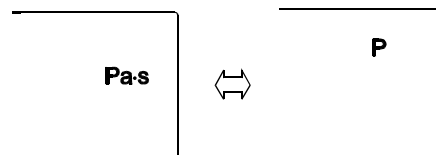

#### Note

- While the measurement is being performed using the graphing program RsVisco, unit changes using the **MODE** key is not available.
- With the function setting "Fnc I", pressing the **MODE** key during measurement will display the measurement elapsed time.

# 7. USING THE WATER JACKET

## 7-1 Introduction

The water jacket, is used with the SV-A Series Vibro Viscometer, to maintain the sample temperature constant or to measure the viscosity when the sample temperature is changed. The operating temperature range is 0°C to 100°C.

The water jacket consists of the following:

Water jacket	1 pc (Main body: PC (Polycarbonate), Packing: Silicone rubber, Washer: Nylon)
Screw	1 pc (Screw: POM (Polyacetal), Washer: Nylon)

### Note

- As a heating medium, use water, isopropyl alcohol (IPA), mixture of water and IPA, or silicone oil, which does not erode the materials described above. Using the heating medium other than these may damage the water jacket.
- When using the water jacket, make sure that no inner pressure is exerted in the water jacket due to the kinked or blocked tubes, as that could exert the pressure in the water jacket, causing it to break.
- To control the temperature, a commercially available constant temperature bath is required separately.
- With the SV-H Series, the water jacket is included in the option AX-SV-54 (Cup set, sold separately, capacity: 10 mL · 13 mL · 45 mL) or option AX-SV-55 (Cup set, sold separately, capacity: 2 mL, only for the SV-1A/ SV-1H). Also, use the optional AX-SV-51 stand set (sold separately) if necessary. If you use the optional AX-SV-53-EX software set (sold separately), you can easily evaluate the graphing data and sample characteristics in real time.
- The operating temperature range of the disposable cup is 0°C to 80°C.

## 7-2 Installation

With the SV-1A, as the viscometer, the sample cup holder and the sample cup (capacity: 2 mL) provided or the glass sample cup (capacity: 2 mL) also provided, is used.

With the SV-10A/100A, as the viscometer, the small sample cup (capacity: 10 mL) provided or the glass sample cup (capacity: 13 mL) also provided, is used.

To circulate the heating medium into the water jacket, a commercially available constant temperature bath is required.

- 1 Using silicone tubes with an inside diameter of 8 mm, make a connection between the "OUT" connector of the bath and the lower nozzle of the water jacket indicated as **1** in the illustration, and then, between the "IN" connector and the upper nozzle indicated as **2**.

It is recommended that, for safety, a commercially available tubing clamp (clamping size: 11 to 20 mm) be used to fasten the tube securely to the nozzle.

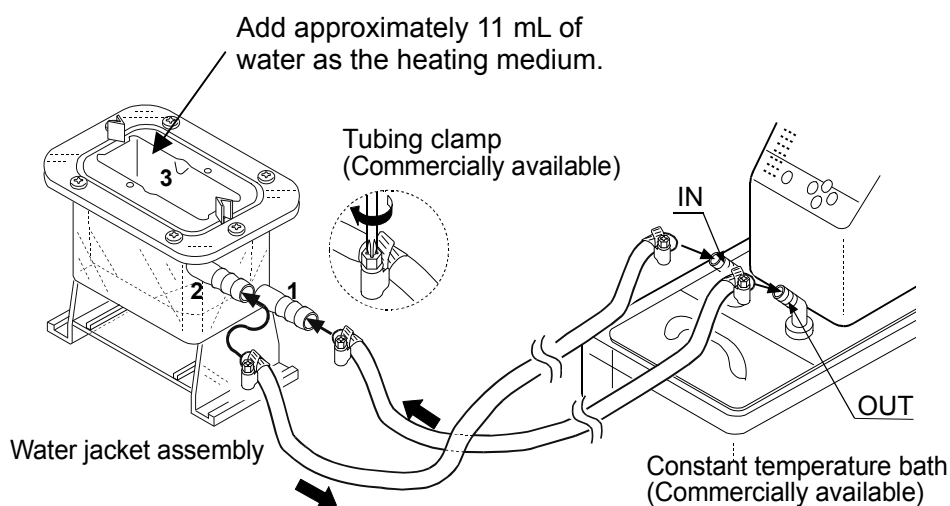

- 2 Pour the heating medium into the water jacket indicated as **3**. An appropriate sample amount is approximately 11 mL.

The heating medium conducts the heat of the water jacket to the sample cup.

**Note: When the levels of the sample surface and the heating medium surface are the same and it is hard to determine the position of the sensor plates, change the amount of the heating medium.**

- 3 When the sample cup (capacity: 2 mL) is used, pour the sample into the cup and confirm that the sample surface is between the 1.8 mL line and the 2 mL line. When the small sample cup (capacity: 10 mL) is used, pour the sample up to the 10 mL line.

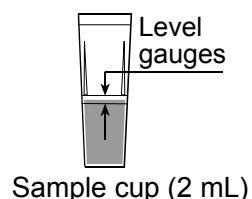



4 **Model: SV-1A**

Insert the sample cup into the sample cup holder, and then into the water jacket indicated as 3. When the specific gravity of the sample liquid is small and the sample cup floats, secure lightly the front side of the cup to the water jacket using the screw provided.

**Model: SV-10A/SV-100A**

Insert the small sample cup into the water jacket indicated as 3.

When the specific gravity of the sample liquid is small and the small sample cup floats, secure lightly the front side of the cup to the water jacket using the screw provided.

Use the small sample cup cover for volatile samples.

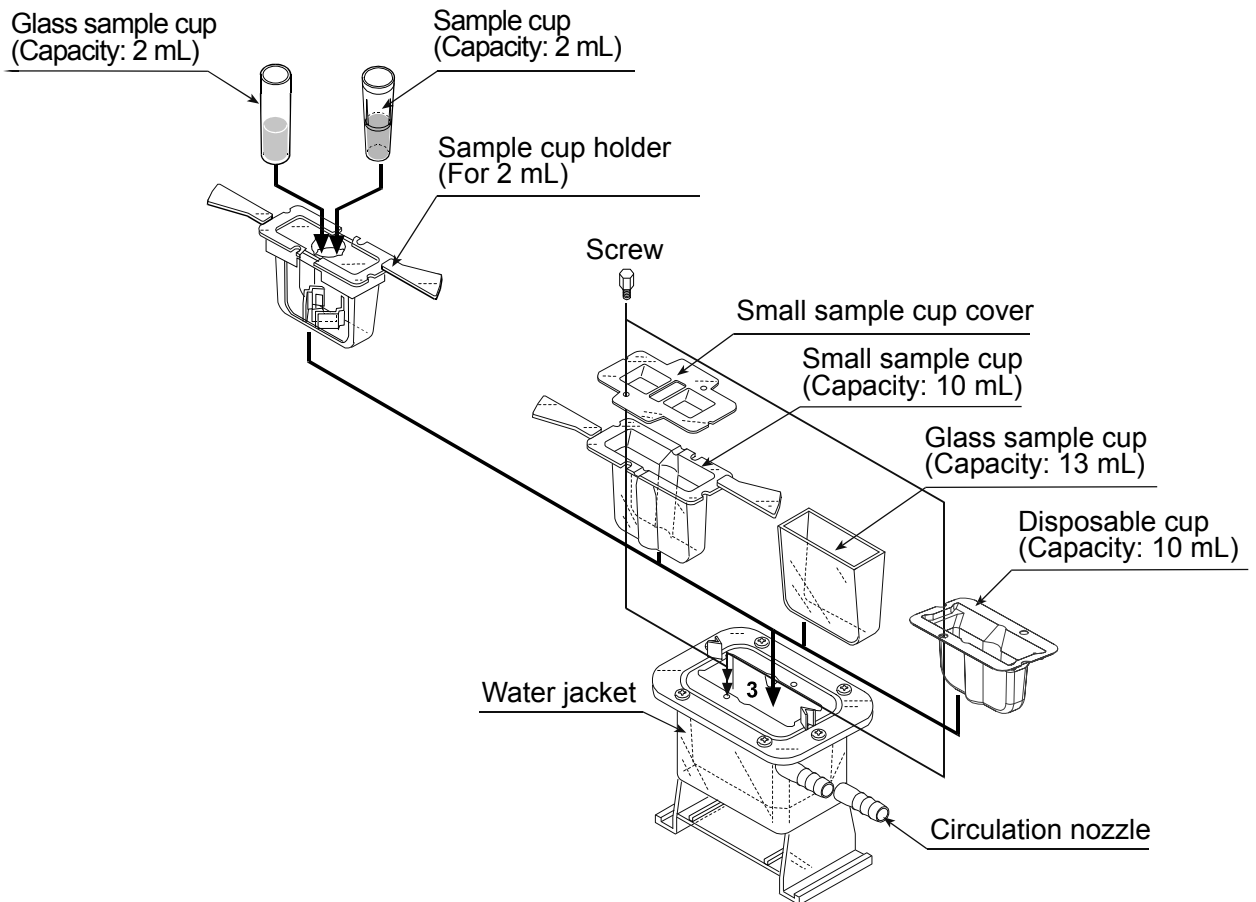

If the handles of the sample cup holder or the small sample cup interfere with the measurement, they can be removed.

Apply force in the up and down directions slowly as shown in the illustration, to break the handle off.

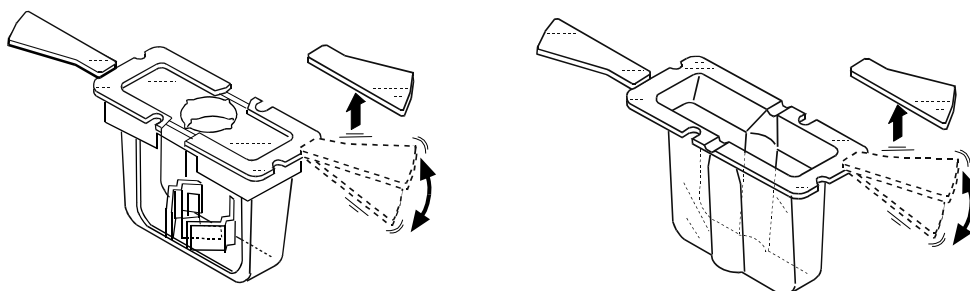

### 7-3 How to Use

- 1 Attach the water jacket on the table along the guides. Make sure that the water jacket is slid furthest along the guides until stopped.

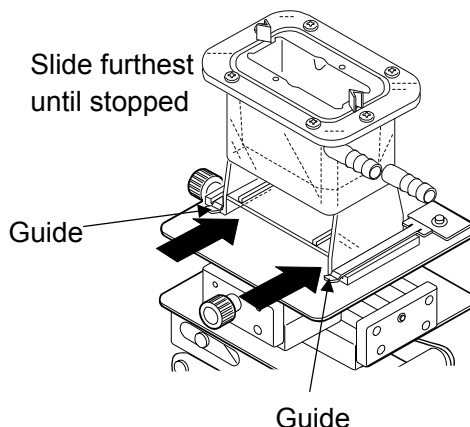

- 2 When the water jacket is used, be sure to raise or remove the protector.

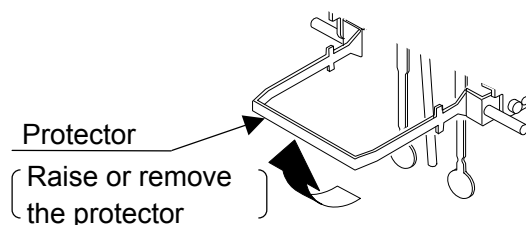

- 3 Use much care so that the sensor plates and the temperature sensor do not come into contact with the inner wall of the sample cup. If they are in contact, a measurement error may occur.

- 4 Be sure to adjust the sample surface to the center of the narrow part of the sensor plates.

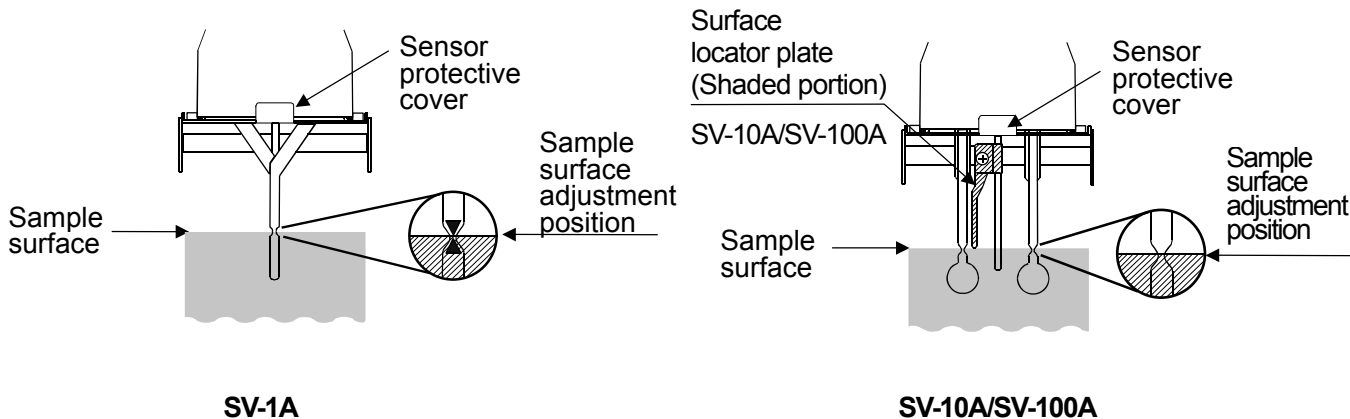

## 7-4 Measuring the Absolute Value of Viscosity Using the Small Sample Cup

---

The SV-10A/100A has been calibrated using the accessory sample cup (45 mL) when shipped. The distance between the inner wall and the sensor plates when the accessory sample cup is used, differs from the distance when the small sample cup (10 mL) is used. This causes a difference in the sensor plate's detection capability, thus causing a difference in the viscosity measured.

Therefore, to measure the absolute value of viscosity using the small sample cup (10 mL), it is recommended that calibration be performed using a fluid with a known viscosity value which is close to the sample viscosity. (Refer to "9. VISCOSITY CALIBRATION".)

## 7-5 Maintenance

---

Clean the sample cup as necessary. If cleaning is not sufficient, a measurement error may occur due to contamination.

## 7-6 Specifications

---

Operating temperature: 0°C to 100°C

Circulation nozzle outside diameter: 10.5 mm

Recommended hose: Silicone tube with an inside diameter of 8 mm

- When a stirrer is attached at the bottom of the water jacket, the sample viscosity can be measured while the sample is being stirred. The maximum viscosity value which can be measured is 1000 mPas.

Stirrer: Cimarec™ i Micro Stirrers manufactured by Thermo Fisher Scientific

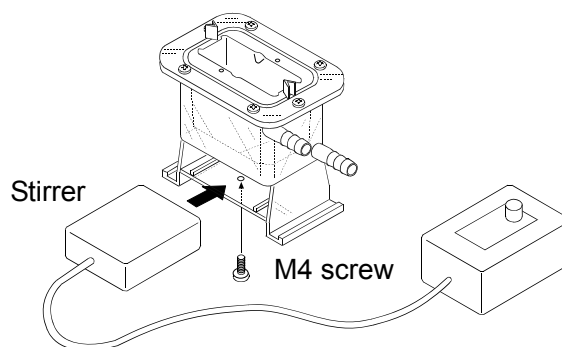

### Note

- Use a rotator with a size of 6 mm (length) x 4 mm (diameter).
- Attach the stirrer to the bottom of the water jacket, using an M4 screw from below.
- When the rotator is used, make sure that the rotator will not touch the temperature sensor or the sensor plates. If it does, increase the sample amount so that the rotator will be farther away from the sensor plates.
- Use the stirrer with a revolution speed which will not cause ripples in the sample surface.

## 8. USING THE DISPOSABLE CUP

### 8-1 Introduction

The disposable cup is a cup with a capacity of 10 mL to be used in combination with a sample cup (capacity: 35 mL to 45 mL) or the water jacket. It can be disposed of after use.

The operating temperature range is 0°C to 80°C.

### 8-2 How to use

#### Using with a sample cup (Capacity: 35 mL to 45 mL)

Place the disposable cup into the sample cup.

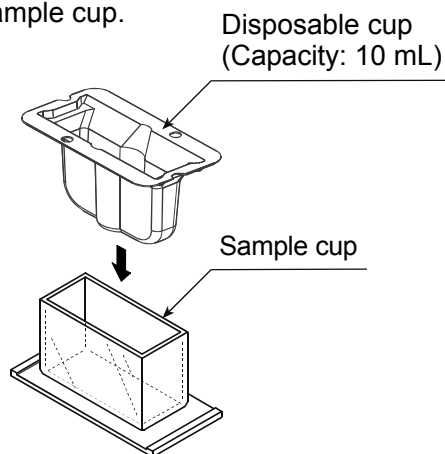

Pour the sample into the disposable cup up to the 10 mL line and measure the viscosity.

#### Using with the water jacket

Place the disposable cup into the water jacket. Secure the cup to the water jacket using the screw provided with the water jacket.

- When used with the water jacket, in combination with a constant temperature bath for circulating the heating medium, the viscosity can be measured while changing the sample temperature or maintaining it constant.

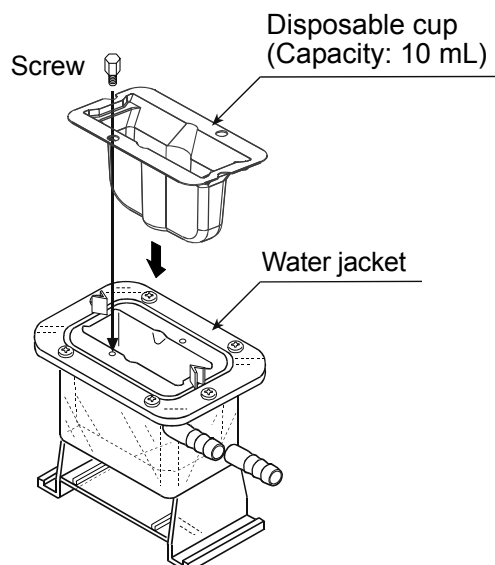

Pour the sample into the disposable cup up to the 10 mL line and measure the viscosity.

### 8-3 Measuring the Absolute Value of Viscosity Using the Disposable Cup

---

The SV-10A/100A has been calibrated using the accessory sample cup (45 mL) when shipped. The distance between the inner wall and the sensor plates when the accessory sample cup is used, differs from the distance when the disposable cup is used. This causes a difference in the sensor plate's detection capability, thus causing a difference in the viscosity measured.

Therefore, to measure the absolute value of viscosity using the disposable cup, it is recommended that calibration be performed using a fluid with a known viscosity value which is close to the sample viscosity. (Refer to "9. VISCOSITY CALIBRATION".)

### 8-4 Specifications

---

Capacity	10 mL
Material	Polyethylene terephthalate (PET)
Operating temperature range	0°C to 80°C
Dimensions	67 (W) x 36 (D) x 41 (H) mm
Wall thickness	0.8 mm
Mass	Approx. 3.3 g

## 9. VISCOSITY CALIBRATION (FOR ALL MODELS)

- With the SV-H series, when calibration is needed, use the stand set (AX-SV-51, sold separately)
- Viscosity calibration is to correct the viscosity value.
- Two calibration methods are available: one-point calibration and two-point calibration, using standard viscosity fluids.
- It is recommended that calibration be performed using a fluid with a known viscosity value which is close to the sample viscosity.  
When the measuring range is great, perform two-point calibration. Two-point calibration requires two standard viscosity fluids (high viscosity and low viscosity) that are appropriate for the measuring range.
- With the SV-1A/1H/10A/10H, when measuring the viscosity near 1 mPa·s, simplified calibration using purified water, which is a one-key operation, is available. The SV-1A/1H/10A/10H has a built-in function to perform an automatic temperature compensation on the viscosity value, based on the temperature of the purified water used.
- In one-point and two-point calibration, the viscosity of a fluid with a known value, such as a standard viscosity fluid, is measured, displayed, corrected digitally and saved in memory.
- To obtain the absolute viscosity value precisely, use the correction value as described in "5-5-2 At calibration".
- If the wrong calibration data such as a wrong correction value have been entered, the viscometer condition can be restored to the factory setting. For details, refer to "Initialization ([*L*])" of the function setting.

### 9-1 Notes on Viscosity Calibration (For all models)

- Pay close attention to the liquid temperature at calibration. Be sure to enter the temperature corrected viscosity value of the liquid at calibration. Even when using a standard viscosity fluid, the temperature change near room temperature causes viscosity change. If the temperature rises, the viscosity value decreases about 2 to 10 percent per degree Celsius. And even when using purified water, temperature rise causes viscosity decrease of about 2 percent per degree Celsius.
- The temperature of the standard viscosity fluid must be the same as the temperature of the sensor plates and the temperature sensor. Allow the displayed temperature to stabilize before calibration.
- Be sure to adjust the sample surface to the center of the narrow part of the sensor plates. Otherwise, a measurement error may occur.
- In the calibration mode, the unit of viscosity for the SV-1A/1H/10A/10H is mPa·s, the unit of viscosity for the SV-100A/100H is Pa·s. The unit of temperature is fixed to °C.
- Influence caused by the sample cup

The viscometers have been calibrated with the following cups when shipped. When using other cups, calibrate the viscometer using the sample cup that will be used for measurement and then measure the viscosity.

SV-1A/SV-1H

Sample cup (Capacity: 2 mL)

SV-10A/SV-10H/SV-100A/SV-100H

Sample cup (Capacity: 45 mL)

#### Note

**Models SV-10A/SV-10H/SV-100A/SV-100H, have been calibrated with the protector attached when shipped. Please note that the value, obtained when the viscometer is calibrated without the protector, may be different from that upon shipment.**

- If water other than purified water (such as pressurized tap water) is used for simplified calibration, or the water temperature is different from the ambient temperature, bubbles may accumulate on the sensor plates and cause a measurement error. Remove any accumulated bubbles before calibration.
- If the measured viscosity of the water is 3.00 mPa·s or greater, it is contaminated and simplified calibration cannot be performed using it. Replace the water.

## 9-2 Calibration Procedure (For all models)

---

### Note

As to the correction value used for one-point calibration and two-point calibration, enter the product of the absolute viscosity value and the density of the standard viscosity fluid. For details, refer to "5-5-2 At calibration".

After calibration, check the values, comparing the product described above with the displayed value.

$$\text{Kinetic viscosity} = \frac{\text{Viscosity}}{\text{Density}} \quad \text{From this, Viscosity} \times \text{Density} = \frac{\text{Viscosity}^2}{\text{Kinetic viscosity}} \quad \text{is obtained.}$$

**Example 1:** To calibrate the viscometer using a standard viscosity fluid:

Using the calculation sheet, calculate the value used for calibration.

- (1) Check the kinetic viscosity and the viscosity at the temperature when the calibration is performed.

Here, 1011 mm<sup>2</sup>/s for the kinetic viscosity and 889 mPa·s for the viscosity at 20°C as an example.

- (2) Substitute the values above to obtain the value for  $\frac{\text{Viscosity}^2}{\text{Kinetic viscosity}}$ .
 
$$\frac{889^2}{1011} \cong 781$$

781 mPa·s is obtained as a correction value used for calibration.

**Example 2:** To calibrate using a standard viscosity fluid with known values of viscosity and density. In this example, a standard viscosity fluid with a viscosity of 889 mPa·s at 20°C is used.

- (1) Check the viscosity value and the density of the standard viscosity fluid at the temperature when the calibration is performed..

Here, 889 mPa·s for the viscosity and 0.878 for the density at 20°C as an example.

- (2) Substitute the values above to obtain the value for Viscosity × Density.

$$889 \times 0.878 \cong 781$$

781 mPa·s is obtained as a correction value used for calibration.

## One-point calibration

- In the standby mode, press and hold the **HOLD** key to enter the calibration mode. "CAL" appears.
- Select one-point calibration (CAL-1) and press the **PRINT** key to confirm. The standby mode of the one-point calibration mode appears. Use the **MODE** key to switch between the calibration modes, one-point calibration (CAL-1) or two-point calibration (CAL-2).  
\* Press the **STOP** key to exit the calibration mode. The display returns to the standby mode.
- Place the standard viscosity fluid in the sample cup. Press the **START** key to start a measurement.
- After the measurement, wait for the display to become stable and press the **PRINT** key. The measurement value blinks and is ready to be corrected.
- Correct the value using the following keys:
  - MODE** key Switches the blinking digits.
  - START** key Changes the setting of a blinking digit.
  - STOP** key Moves the decimal point.
- Press the **PRINT** key to confirm the correction value.  
 (To correct the value:  
 With "End" being displayed, press the **STOP** key and correct the value.)
- To exit the calibration mode:  
 With "End" being displayed, press the **PRINT** key again to return to the standby mode.
- Measure the viscosity of the standard viscosity fluid used. Confirm that the viscometer displays the similar value as the entered correction value.

Below is an example of the SV-10H.

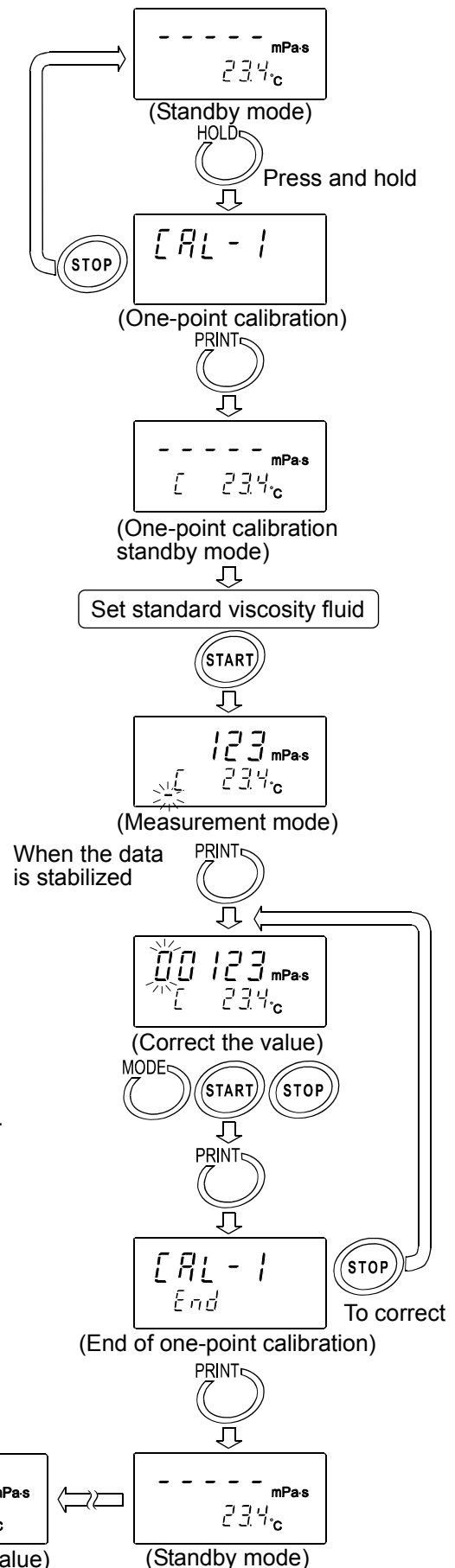



## Two-point calibration

- In the standby mode, press and hold the **HOLD** key to enter the calibration mode. "CAL" appears.
- Select two-point calibration (CAL-2) and press the **PRINT** key to confirm. The standby mode of the two-point calibration mode appears. Use the **MODE** key to switch between the calibration modes, one-point calibration (CAL-1) or two-point calibration (CAL-2).  
\*Press the **STOP** key to exit the calibration mode. The display returns to the standby mode.
- In two-point calibration mode, the calibration mode ID indicator (-) appears below the temperature display.
- Place the standard viscosity fluid in the sample cup. Press the **START** key to start the measurement of the first point.
- After the measurement, wait for the display to become stable and press the **PRINT** key. The measurement value blinks and is ready to be corrected.
- Correct the value using the following keys:
 

<b>MODE</b> key	Switches the blinking digits.
<b>START</b> key	Changes the setting of a blinking digit.
<b>STOP</b> key	Moves the decimal point.
- Press the **PRINT** key to confirm the correction value.
- To correct the value:  
In the calibration standby mode to enter the second point, press the **STOP** key and correct the value.

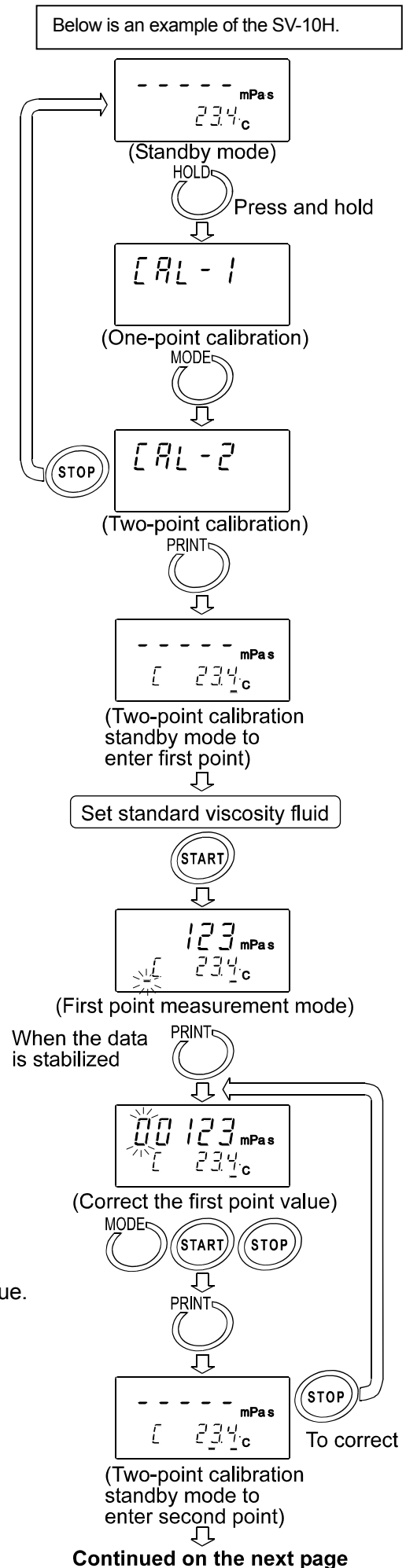

Continued on the next page

9 When the measurement of the first point has completed, clean the sensor plates, temperature sensor and protector and prepare the second standard viscosity fluid.

10 Place the second standard viscosity fluid in the sample cup. Press the **START** key to start the measurement of the second point.

11 After the measurement, wait for the display to become stable and press the **PRINT** key. The measurement value blinks and is ready to be corrected.

12 Correct the value using the following keys:

**MODE** key Switches the blinking digits.

**START** key Changes the setting of a blinking digit.

**STOP** key Moves the decimal point.

13 Press the **PRINT** key to confirm the correction value.

To correct the value:  
With "End" being displayed, press the **STOP** key and correct the value.

14 To exit the calibration mode:

With "End" being displayed, press the **PRINT** key again. The calibration data is saved and the display returns to the standby mode.

15 Measure the viscosity of the two standard viscosity fluids used. Confirm that the viscometer displays the similar value as the entered correction value for each fluid.

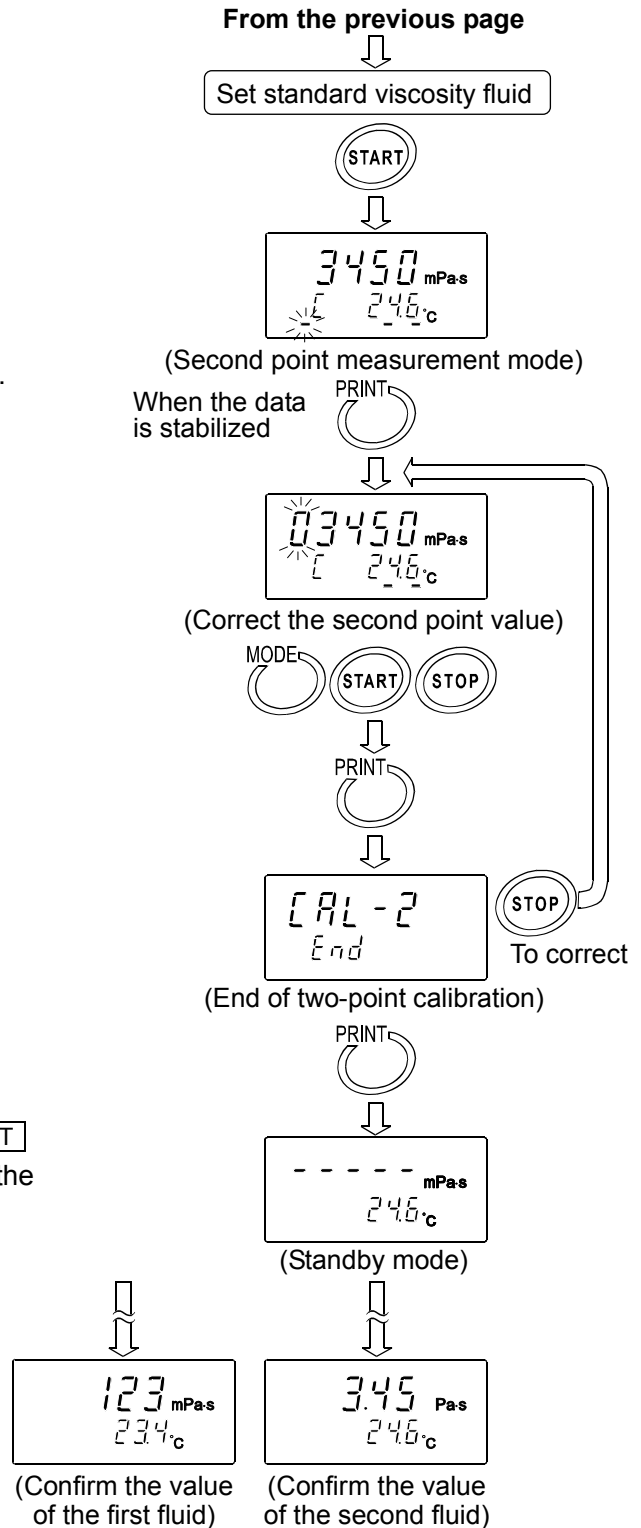

## Simplified calibration using purified water (SV-1A/1H/10A/10H)

- 1 Place the purified water in the sample cup.
- 2 Press the **START** key to measure the purified water. Confirm that the viscosity and temperature values are stabilized.
- 3 Press and hold the **START** key. The theoretical viscosity value (Viscosity × Density) of the purified water at the measuring temperature is displayed and all the displays blink.

To cancel the operation, press the **STOP** key. The display returns to the status before calibration.

- 4 Press the **START** key again to perform calibration. When calibration is completed, "End" is displayed. Then, the viscosity returns to the measuring status.

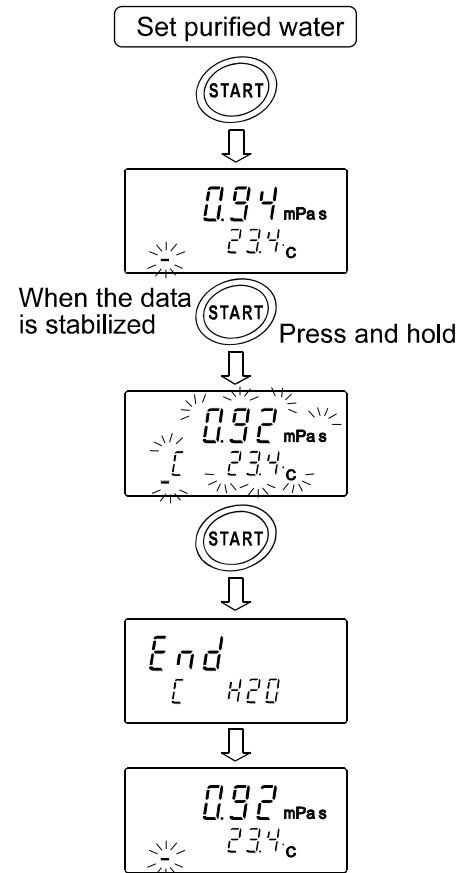

Reference data: Theoretical viscosity value (Viscosity × Density)  
of the purified water at various temperatures

Temperature (°C)	Viscosity × Density (mPa·s)
10.0	1.31
11.0	1.27
12.0	1.24
13.0	1.20
14.0	1.17
15.0	1.14
16.0	1.11
17.0	1.08
18.0	1.05
19.0	1.03
20.0	1.00
21.0	0.98
22.0	0.95
23.0	0.93
24.0	0.91
25.0	0.89
26.0	0.87
27.0	0.85
28.0	0.83
29.0	0.81
30.0	0.79

**Note**

- When tap water is poured into the sample cup directly and is measured, bubbles are generated on the sensor plates due to the difference in pressure and temperature and the viscosity may increase gradually. Pressurized tap water generates bubbles easily. Therefore, use distilled or purified water that is not pressurized. Leave the sensor plates and sample in the same environment to acclimatize before measuring, to decrease temperatures fluctuations.
- In a measurement that takes a long time, the sample viscosity may increase due to water contamination. Perform a periodic check on water quality.

# 10. FUNCTION SETTING (FOR ALL MODELS)

The viscometer, by selecting functions to be used in the function setting, can specify the performance appropriate to the usage.

Each function is assigned parameters. The performance of a function is specified by changing the parameter.

The parameters saved, even if the power is turned off, are maintained in non-volatile memory.

## 10-1 Operation (For all models)

The operational procedure of the function setting is as follows:

- 1 In the standby mode, press and hold the **MODE** key to enter the function setting mode.
- 2 Press the **MODE** key to select a function item.
- 3 Press the **PRINT** key to confirm the function item. The changeable digit blinks.
- 4 Press the **START** key or **HOLD** key to change the blinking digit.
  - START** key Increases the value of the blinking digit. When the value reaches the upper limit of the setting range, the minimum value appears again.
  - HOLD** key Decreases the value of the blinking digit. When the value reaches the lower limit of the setting range, the maximum value appears again.
- 5 To save the new setting, press the **PRINT** key. After "End ", the next item is displayed. To cancel the new setting, press the **STOP** key. The next item is displayed.
- 6 To change other settings, repeat the procedure starting at step 2.
- 7 To exit the function setting mode, press the **STOP** key. The viscometer returns to the standby mode.

### Note

The operational procedures for setting the date and time ("CLAdj"), ID number ("id") and initialization ("CLR") are not the same as the procedure described above. Refer to "10-3 Description of Items".

"Date/Time"                      pages 62-64

"ID Number Output"            pages 59-60

### Example of the function setting procedure

To change the setting of "Unit upon power-on (*Unit*)" to the viscosity: cP (Centipoise) and the temperature: °C (Celsius).

- 1 In the standby mode, press and hold the **MODE** key to enter the function setting mode. "50tYP" appears.

- 2 Press the **MODE** key to select "Unit".

- 3 Press the **PRINT** key to confirm the item.  
(The decimal point illuminates when the setting currently saved is displayed.)

- 4 Press the **START** key or **HOLD** key to select the unit to be used.  
(In this example, "2" is selected. Viscosity: cP, Temperature: °C)

- 5 Press the **PRINT** key to save the setting.  
After "End", the next item is displayed.

- 6 Press the **STOP** key to return to the standby mode.

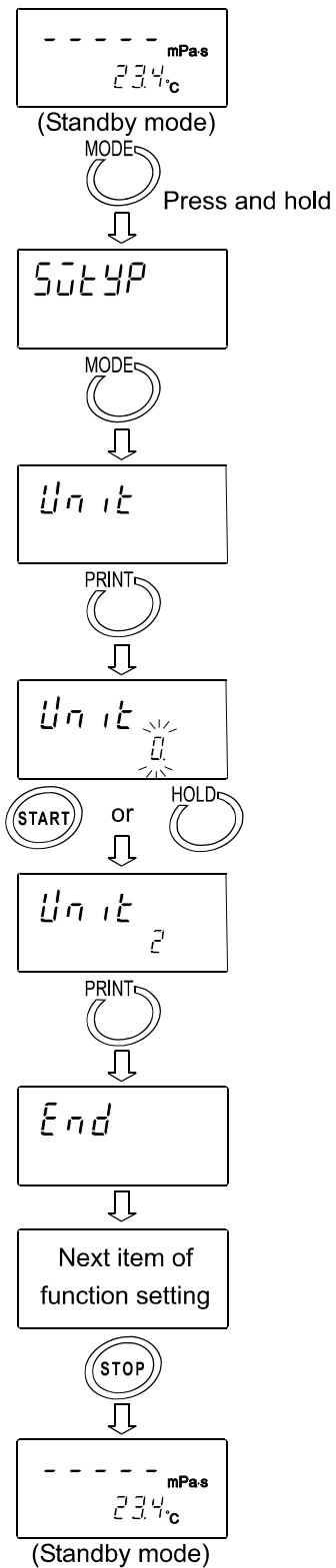

## 10-2 Details of the Function Items (For all models)

Function item	Parameter	Description				
<i>StYP</i>	<i>HtYPE</i> •	Portable type (This function can use: <i>H-Fnc</i> , <i>St-b</i> , <i>HLd-t</i> , <i>CP</i> , <i>bEP</i> , <i>CP H</i> , <i>CP Lo</i> ) Factory setting of the SV-H series				
Change types	<i>RtYPE</i> •	Stand type (This function cannot use: <i>H-Fnc</i> , <i>St-b</i> , <i>HLd-t</i> , <i>CP</i> , <i>bEP</i> , <i>CP H</i> , <i>CP Lo</i> ) Factory setting of the SV-A series				
<i>Cond</i>	0	Follows the viscosity changes quickly. (Prone to vibration)				
Condition	1 •	Follows the viscosity changes slowly. (Stable values)				
	2					
<i>Unit</i>	0 •	Viscosity	mPas	Temperature	°C	Factory setting: SV-1A/1H/10A/10H=0 SV-100A/100H=1
Unit upon power-on	1 •		Pas			
	2		cP			
	3		P			
	4		mPas			
	5		Pas			
	6		cP			
	7		P			
<i>Pnt</i>	0 •	Dot		With "Comma" selected, the separator for CSV format will be ";" (semicolon).		
Decimal point	1	Comma				
<i>Fnc</i>	0 •	Switches viscosity units.				
[MODE] key function during measurement	1	Switches between the temperature display and the measurement elapsed time display.				
	2	Does not display the digits that are beyond the decimal point.				
<i>Prt</i>	0 •	Key mode		Press the [PRINT] key to output data.		
Data output mode	1	Auto print mode		Outputs automatically when the [STOP] key ends the measurement.		
	2	Stream mode		Continuous output during measurement. Outputs the viscosity only when D.P. format is selected.		
<i>TYPE</i>	0	A&D standard format		For AD-8121B MODES 1&2		
Data output format	1 •	D.P. format		For AD-8121B MODE 3		
	2	CSV format		For a personal computer		
	3	RsVisco format		For graphing program RsVisco		
<i>S-Rt</i>	0	No output		Available only for D.P. format		
Measurement elapsed time output	1 •	Output				
<i>S-td</i>	0	No output		Available only for D.P. and CSV formats		
Date/time output	1 •	Output				
<i>S-Ed</i>	0	No output				
Other output	1	Outputs remarks.		Available only for D.P. format		
	2 •	Outputs remarks, Device ID information and signature.				
	3	Outputs ID number.		Available only for CSV format		
<i>PUSE</i>	0	No pause				
Pause at data output	1 •	Pause (Approx. 2 seconds)				
<i>ErFnc</i>	0 •	Usually use this parameter.				
Reserved	1					
	7					
<i>H-Fnc</i>	0	Off				
Function of portable type	1 •	Auto hold function				
	2	Timer mode function				

• Factory setting

<i>St-b</i>	0	Stable when within $\pm 5\%$ ↑ ↓ Stable when within $\pm 15\%$	This function is available when the auto hold function ( <i>H-Fnc 1</i> ) is used.
Stability band width	1 •		
	2		
<i>Hld-t</i>	0	15 seconds	This function is available when the timer mode function ( <i>H-Fnc 2</i> ) is used.
Hold time	1 •	30 seconds	
	2	45 seconds	
	3	1 minute	
<i>CP</i>	0 •	No comparison	
Comparator mode	1	Comparison	
<i>bEP-</i>	0 •	Off	On Sounds the buzzer, when the displayed viscosity value equal to or lower than the lower limit value that is set.
Lo buzzer	1	On	
<i>bEP-</i>	0 •	Off	On Sounds the buzzer, when the displayed viscosity value is between the lower and upper limit values that are set.
OK buzzer	1	On	
<i>bEP+</i>	0 •	Off	On Sounds the buzzer, when the displayed viscosity value equal to or greater than the upper limit value that is set.
HI buzzer	1	On	
<i>CP Hi</i>		This function can be used with " <i>CP 1</i> ". Refer to "Comparator ( <i>CP</i> )" in "10-3 Description of Items."	
Upper limit value			
<i>CP Lo</i>		Sets the ID number.	
Lower limit value			
<i>id</i>			By setting " <i>S-Ed</i> ", the ID number can be added to the measurement data.
<i>CLr</i>		Restores the function settings and calibration data to the factory settings.	
<i>CLAdd</i>		Sets the order of the date (YMD,MDY,DMY) and the date/time.	
Date/Time			

- Factory setting



## 10-3 Description of Items (For all models)

### Condition (Cond)

The stability of the viscosity measurement results can be adjusted, taking ambient conditions such as vibration into consideration.

Parameter	Settings	Description
0	Follows the viscosity changes quickly. (Prone to vibration)	When the viscosity value is unstable due to external vibration, set a greater parameter.  To measure while following the rapid changes in viscosity, set a smaller parameter.  With a smaller setting, the measurement is prone to external vibration. Consider the ambient conditions of the installation site.
1	↑ ↓	
2	Follows the viscosity changes slowly. (Stable values)	

### Unit Upon Power-on (Unit)

The units of viscosity and temperature displayed when the power is turned on are specified.

SV-1A/1H/10A/10H

Parameter	Settings			Description
0	Viscosity	mPa·s (Millipascal second)	Temperature	In the standby mode, pressing the <b>MODE</b> key switches the viscosity unit. mPa·s ↔ Pa·s, cP ↔ P  With "Fnc 0" selected, units can be switched even during measurement. *1
1		Pa·s (Pascal second)		
2		cP (Centipoise)		
3		P (Poise)		
4		mPa·s (Millipascal second)		
5		Pa·s (Pascal second)		
6		cP (Centipoise)		
7		P (Poise)		
				°C (Celsius)  °F (Fahrenheit)

\*1 While receiving the measurement data using the graphing program RsVisco, changing the mode using the **MODE** key is not available.

For the viscosity over 1000 mPa·s, the unit is fixed to Pa·s. For the viscosity over 1000 cP, the unit is fixed to P.

### Decimal Point (Pnt)

Parameter	Settings	Description
0	Dot "."	The decimal point format for the displayed measurement data and the decimal point code for measurement data output via RS-232C are specified.  With "Comma" selected, the separator for CSV format and RsVisco format will be ";" (semicolon).
1	Comma ","	

## MODE Key Function During Measurement ( $F_{nc}$ )

Parameter	Settings	Description
□ •	Switches the viscosity units.	<p>Each time the <b>MODE</b> key is pressed, the viscosity unit is switched.</p> <p>SV-1A / 1H / 10A / 10H: mPa·s ↔ Pa·s, cP ↔ P            SV-100A / 100H : Pa·s ↔ P</p> <p><b>Note</b>  <b>With the SV-1A / 1H / 10A / 10H, for the viscosity over 1000 mPa·s, the unit is fixed to Pa·s and for the viscosity over 1000 cP, the unit is fixed to P.</b></p>
	Switches between the temperature display and the measurement elapsed time display	<p>Each time the <b>MODE</b> key is pressed, the display is switched between the temperature display and the measurement elapsed time display.</p> <p>Upon a measurement start, the temperature display is selected.</p> <p>When the elapsed time reaches 100 hours, the display returns to 0. (99.59.59→00.00.00)</p>
∩	Does not display the digits that are beyond the decimal point	<p>Each time the <b>MODE</b> key is pressed, the digits that are beyond the decimal point disappear.</p> <p>But with 100-999mPa·s, always displays the digits that are beyond the decimal point</p> <p>When using with the portable type, use this function when you need to conceal the large variation in digits.</p>

## Data Output Mode ( $P_{rt}$ )

The condition to output the measurement data via RS-232C is set.

Parameter	Settings	Description
□ •	Key mode	During measurement or in the data hold mode, pressing the <b>PRINT</b> key outputs the current measurement values. *2
	Auto print mode	<p>The measurement values are output automatically when the <b>STOP</b> key ends the measurement.</p> <p>Pressing the <b>PRINT</b> key outputs the current measurement values.</p>
∩	Stream mode	<p>The measurement values are output continuously during measurement.</p> <p>When D.P. format is selected in "Output format (<math>tYPE</math>)" of the function setting, only the viscosity value is output, regardless of the settings of "S-Rt", "S-td" and "S-Ed".</p> <p>When this mode is selected, the data hold mode using the <b>HOLD</b> key is not available.</p>

## Data Output Format (TYPE)

The output format appropriate for the device connected to RS-232C can be selected.

Parameter	Settings	Description
0	A&D standard format	Used with the printer MODE 1 or MODE 2 when the optional compact printer AD-8121B is connected. Only the viscosity value is output.
1 •	D.P. format	Used with the printer MODE 3 when the optional compact printer AD-8121B is connected.  With "Prt 0" or "Prt 1" selected for "Data output mode (Prt)", output contents can be selected by the settings of "S-Rt", "S-t d" and "S-E d".  With "Prt 2" selected for "Data output mode (Prt)", only the viscosity value is output.
2	CSV format	Appropriate when a personal computer is used to collect data. Measurement values are output in comma separated format.  With "S-t d" and "id" settings, the date/time and ID number can be added to the measurement data.  When a comma is selected as the decimal point by "Pnt 1", a semicolon ";" is used as a data separator.  The viscosity value and the temperature are output using the internal resolution. *3
3	RsVisco format	Used with the graphing program RsVisco.  When a measurement is started using RsVisco, the viscometer automatically selects this format.  The viscosity value and the temperature are output using the internal resolution. *3

\*3 The relation between the measuring unit and the internal resolution is as follows:

	Model	Viscosity				Temperature	
		mPa·s	Pa·s	cP	P	°C	°F
Internal resolution	SV-1A/SV-1H SV-10A/SV-10H	0.01	0.0001	0.01	0.0001	0.01	0.01
	SV-100A SV-100H	–	0.01	–	0.1		

## Measurement Elapsed Time Output (S-Rt)

Parameter	Settings	Description
0	No output	With D.P. format selected, whether or not to add the measurement elapsed time (the time elapsed from a measurement start) to the measurement data can be selected.  For examples of output format, refer to "10-4 Data Output Format Examples".
1 •	Output	

## Date/time Output (S-t d)

Parameter	Settings	Description
0	No output	With D.P. format or CSV format selected, whether or not to add the date and time to the measurement data can be selected.  For examples of output format, refer to "10-4 Data Output Format Examples".
1 •	Output	

### Other Output (5-Ed)

Parameter	Settings	Description
0	No output	
1	Outputs remarks.	With D.P. format selected, whether or not to add remarks, Device ID information or signature to the measurement data can be selected.
2	• Outputs remarks, Device ID information and signature.	For examples of output format, refer to "10-4 Data Output Format Examples".
3	Outputs ID number.	With CSV format selected, whether or not to add ID number to the measurement data can be selected. For examples of output format, refer to "10-4 Data Output Format Examples".

### Pause at Data Output (PUSE)

Parameter	Settings	Description
0	No pause	Whether or not to take a pause of two seconds each time one line is output can be selected, when the data are output via RS-232C.
1	• Pause (Approx. 2 seconds)	When MODE 3 of the optional compact printer AD-8121B is used, select "1".

### Function of portable type (H-Fnc)

Parameter	Settings	Description								
0	Off	Does not use the function of portable type								
1	• Auto hold function	When measuring with the portable type, this function is used. When the change of the displayed viscosity values is within the stabilization range for a fixed period of averaging time, the stability value is set to freeze. Press the <b>STOP</b> key again to return to the standby mode. <table border="1" style="margin-left: 20px;"> <thead> <tr> <th>Averaging time</th> <th>Stability band width</th> </tr> </thead> <tbody> <tr> <td>Cond 0 2 seconds</td> <td>St-b 0 Stability band width Small</td> </tr> <tr> <td>Cond 1 4 seconds</td> <td>St-b 1 <span style="display: inline-block; vertical-align: middle;">↑ ↓</span></td> </tr> <tr> <td>Cond 2 20 seconds</td> <td>St-b 2 Stability band width Large</td> </tr> </tbody> </table>	Averaging time	Stability band width	Cond 0 2 seconds	St-b 0 Stability band width Small	Cond 1 4 seconds	St-b 1 <span style="display: inline-block; vertical-align: middle;">↑ ↓</span>	Cond 2 20 seconds	St-b 2 Stability band width Large
Averaging time	Stability band width									
Cond 0 2 seconds	St-b 0 Stability band width Small									
Cond 1 4 seconds	St-b 1 <span style="display: inline-block; vertical-align: middle;">↑ ↓</span>									
Cond 2 20 seconds	St-b 2 Stability band width Large									
2	Timer mode function	After a fixed period, the displayed viscosity value is set to freeze. Press the <b>STOP</b> key again to return to the standby mode.								

## Comparator (CP)

The results of the comparison are indicated by the sound. (It is necessary to set : bEP<sub>-</sub> , bEP<sub>-</sub> , bEP<sub>-</sub>)

- To compare, use: ● Upper limit value and lower limit value  
 Input method: ● Digital input

### Setting example

#### Selecting a comparator mode

- 1 Press and hold the **MODE** key until **5-4P** of the function table is displayed.
- 2 Press the **MODE** key several times to display **CP**.
- 3 Press the **PRINT** key.
- 4 Press the **START** key to display **CP 1** from **CP 0**.
- 5 Press the **PRINT** key to store the selected mode.

#### Entering the upper limit value

- 6 With **CP H,** displayed, press the **PRINT** key. The current setting of the upper limit value is displayed.
  - When the current setting is not to be changed, press the **PRINT** key to proceed to step 7.
  - When the current setting is to be changed, change the setting using the following keys.

<b>MODE</b> key	To select the digit blinking.
<b>START</b> key	To change the value of the digit blinking.
<b>STOP</b> key	To select the position of the decimal point.
<b>PRINT</b> key	To store the new setting and go to step 7.

#### Entering the lower limit value

- 7 With **CP L,** displayed, press the **PRINT** key. The current setting of the lower limit value is displayed.
  - When the current setting is not to be changed, press the **PRINT** key to proceed to step 8.
  - When the current setting is to be changed, change the setting using the following keys.

<b>MODE</b> key	To select the digit blinking.
<b>START</b> key	To change the value of the digit blinking.
<b>STOP</b> key	To select the position of the decimal point.
<b>PRINT</b> key	To store the new setting and go to step 8.

- 8 Press the **HOLD** key to exit the comparator function and return to the standby mode.

## ID Number Output (id)

- The ID number is used to identify the viscometer.
- Whether or not to add the ID number to the measurement data can be selected by "5-Ed" of the function setting.
- The ID number is six characters long. The following characters are available for the ID number.

Character	0	1	2	3	4	5	6	7	8	9	(Space)	-(hyphen)	A	B	C	D	E
Display	0	1	2	3	4	5	6	7	8	9	(Space)	-	A	B	C	D	E

Character	F	G	H	I	J	K	L	M	N	O	P	Q	R	S	T	U	V	W	X	Y	Z
Display	F	G	H	I	J	K	L	M	N	O	P	Q	R	S	T	U	V	W	X	Y	Z

For examples of output format, refer to "10-4 Data Output Format Examples".

## Setting the ID number

- 1 In the standby mode, press and hold the **MODE** key to enter the function setting mode. " *SūtyP* " appears.
- 2 Press the **MODE** key to select " *id* ".
- 3 Press the **PRINT** key to enter the ID number setting mode.
- 4 Set the ID number using the following keys:
  - MODE** key Switches the blinking digits.
  - START** key Increases the value of the blinking digit by one.
  - HOLD** key Decreases the value of the blinking digit by one.
  - STOP** key Cancel the operation.
- 5 Press the **PRINT** key to save the setting. After " *End* ", the next item is displayed.
- 6 Press the **STOP** key to return to the standby mode.

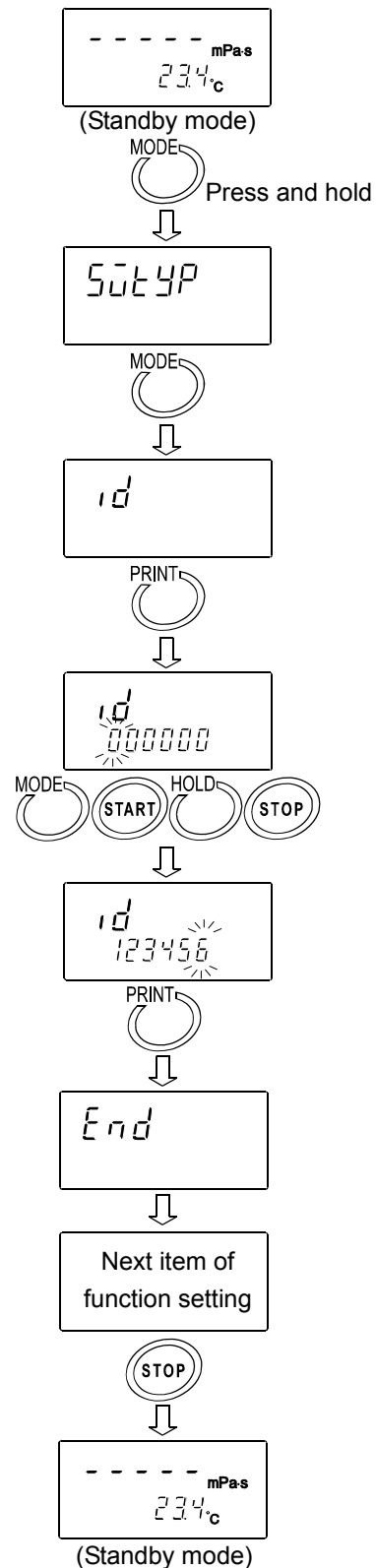

## Initialization (LLr)

Restores the following data to the factory setting.

- Function setting (Setting of "SUtYP" is not returned by this operation)
- Calibration data

After initialization, check the viscosity value and perform calibration as necessary. (Refer to "9. VISCOSITY CALIBRATION").

- 1 In the standby mode, press and hold the **MODE** key to enter the function setting mode. "SUtYP" appears.
- 2 Press the **MODE** key to select "LLr".
- 3 Press the **PRINT** key to display "LLr no".
- 4 Press the **START** key to select "LLr Go".
- 5 Press the **PRINT** key to execute initialization. After "End", the next item is displayed. Initialization has completed.
- 6 Press the **STOP** key to return to the standby mode.

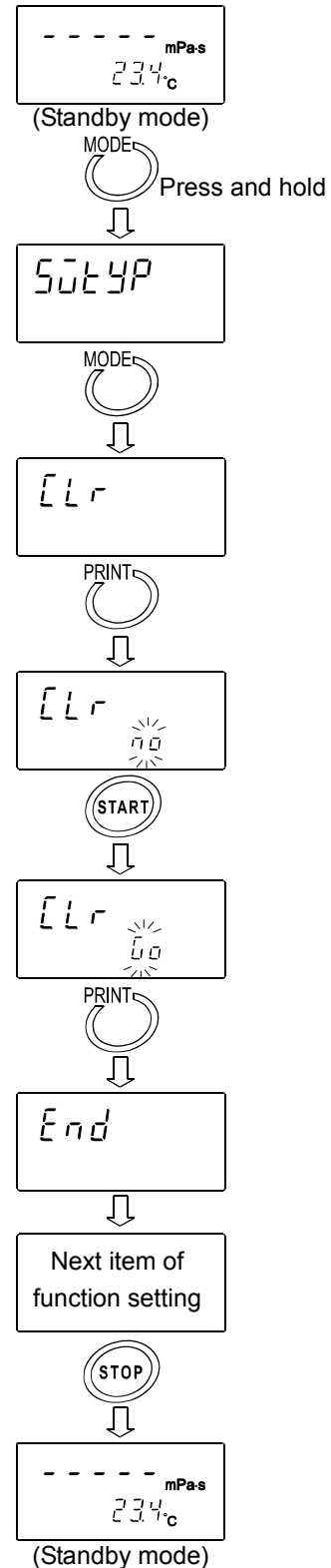

## Date/Time (CLAdj)

- The upper two digits of the year are not displayed. For example, the year 2007 is displayed as "07".
- The time is set using the 24-hour system.
- Do not enter a non-existing date and time.

Set the order of the date, the date and time as follows:

(Example: To change April 5, 2003, 11:22:33 to June 8, 2004, 12:34:00)

- 1 In the standby mode, press and hold the **MODE** key to enter the function setting mode. "SuTYP" appears.

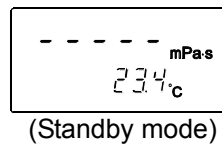

- 2 Release the **MODE** key and press it again to display "CLAdj".

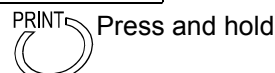
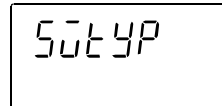

- 3 Press the **PRINT** key to display the current date. When the date is not to be changed, press the **MODE** key to display the current time.

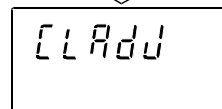

### Changing the order of the date

- 4 Press the **PRINT** key. "Y n d" (Year), "n" (Month) and "d" (Day) blink.

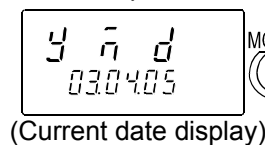

**MODE** → To current time display (Go to page 64)

- 5 Press the **START** key or **HOLD** key to change the order of displaying the date.

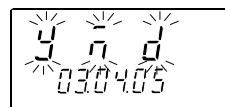
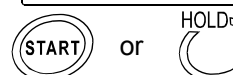
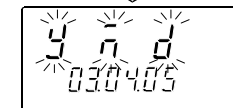

(Year/Month/Day)



(Month/Day/Year)



(Day/Month/Year)



Continued on the next page



## Changing the date

The date is changed in the selected displaying order.

The following is an example when the order of "y" (Year), "n" (Month) and "d" (Day) is selected.

- 6 Press the **MODE** key to select the setting value of "y" (Year). (Example:03)
- 7 Press the **START** key or **HOLD** key to change the year. (Example:03→04)
  - START** key Increases the value of the blinking digit by one.
  - HOLD** key Decreases the value of the blinking digit by one.
- 8 Press the **MODE** key to select the setting value of "n" (Month). (Example:04)
- 9 Press the **START** key or **HOLD** key to change the month. (Example:04→06)
- 10 Press the **MODE** key to select the setting value of "d" (Day). (Example:05)
- 11 Press the **START** key or **HOLD** key to change the day. (Example:05→08)
- 12 Press the **PRINT** key to save the date.  
After "End", the current time is displayed.

From the previous page

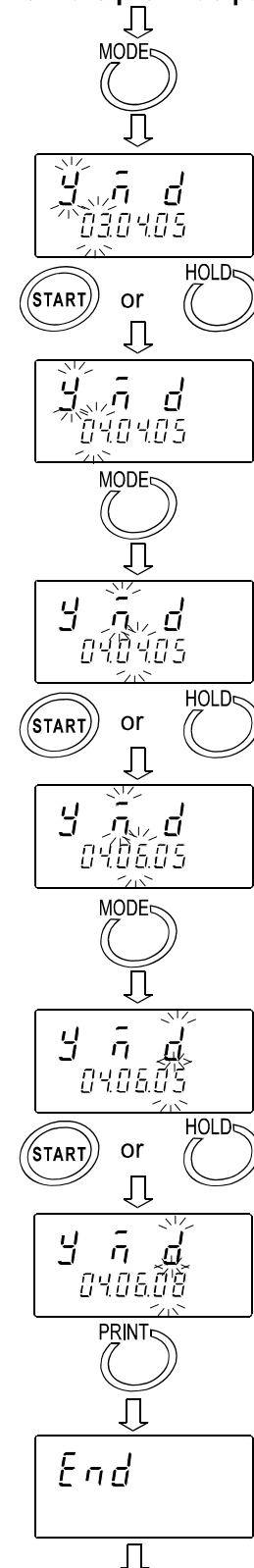

Continued on the next page

## Changing the time

- 13 The current time is displayed. Press the **MODE** key to display the current date.

To current date display  
(Go to page 62)

From the previous page

- 14 Press the **PRINT** key to select the setting value of the hour. (Example:11)

- 15 Press the **START** key or **HOLD** key to change the hour. (Example:11→12)

- 16 Press the **MODE** key to select the setting value of the minute. (Example:22)

- 17 Press the **START** key or **HOLD** key to change the minute. (Example:22→34)

- 18 Press the **MODE** key to select the setting value of the second. (Example:33)

- 19 Press the **START** key or **HOLD** key to change the second. (Example:33→00)

- 20 Press the **PRINT** key to save the time.  
After "End", the next item is displayed.

- 21 Press the **STOP** key to return to the standby mode.

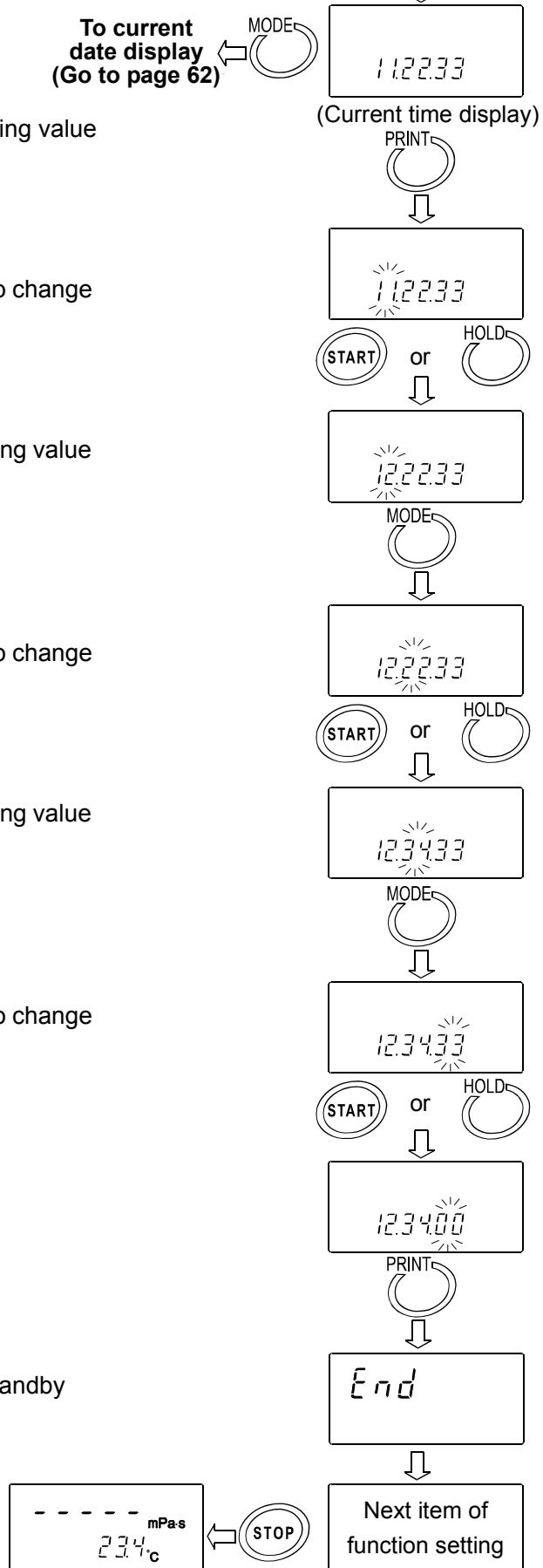

## 10-4 Data Output Format Examples (For all models)

### A&D standard format

Used with the printer MODE 3 when the optional compact printer AD-8121B is connected. Only the viscosity value is output.

### SV-1A/SV-1H output format example

Viscosity unit	Display	Output format	Remarks
mPa·s	L mPa·s	OL, -99999999mPs	Below measuring range error
	0.30mPa·s	ST, +00000.30mPs	
	10.0 mPa·s	ST, +00010.00mPs	The digit of 0.01mPa·s is always zero.
	100 mPa·s	ST, +00100.00mPs	The digits of 0.01mPa·s and 0.1mPa·s are always zero.
	1.00 Pa·s	ST, +01000.00mPs	For 1000mPa·s or greater, the displayed unit is Pa·s, but the output unit remains mPa·s. The digits of 0.01mPa·s, 0.1mPa·s and 1mPa·s are always zero.
	H Pa·s	OL, +99999999mPs	Above measuring range error
Pa·s	L Pa·s	OL, -99999999Pas	Below measuring range error
	0.0003 Pa·s	ST, +000.0003Pas	
	0.0100 Pa·s	ST, +000.0100Pas	
	0.100 Pa·s	ST, +000.1000Pas	The digit of 0.0001Pa·s is always zero.
	1.00 Pa·s	ST, +001.0000Pas	The digits of 0.0001Pa·s and 0.001Pa·s are always zero.
	H Pa·s	OL, +99999999Pas	Above measuring range error
cP	L cP	OL, -99999999 <sub>L</sub> cP	Below measuring range error
	0.30 cP	ST, +00000.30 <sub>L</sub> cP	
	10.0 cP	ST, +00010.00 <sub>L</sub> cP	The digit of 0.01cP is always zero.
	100 cP	ST, +00100.00 <sub>L</sub> cP	The digits of 0.01cP and 0.1cP are always zero.
	10.0 P	ST, +01000.00 <sub>L</sub> cP	For 1000 cP or greater, the displayed unit is P, but the output unit remains cP. The digits of 0.01cP, 0.1cP and 1cP are always zero.
	H P	OL, +99999999 <sub>L</sub> cP	Above measuring range error
P	L P	OL, -99999999 <sub>L</sub> P	Below measuring range error
	0.0030 P	ST, +000.0030 <sub>L</sub> P	
	0.100 P	ST, +000.1000 <sub>L</sub> P	The digit of 0.0001P is always zero.
	1.00 P	ST, +001.0000 <sub>L</sub> P	The digits of 0.0001P and 0.001P are always zero.
	10.0 P	ST, +010.0000 <sub>L</sub> P	The digits of 0.0001P, 0.001P and 0.01P are always zero.
	H P	OL, +99999999 <sub>L</sub> P	Above measuring range error

□ : Space (ASC 20h)

**SV-10A/SV-10H output format example**

Viscosity unit	Display	Output format	Remarks
mPa·s	L mPa·s	OL,-99999999mPs	Below measuring range error
	0.30mPa·s	ST,+00000.30mPs	
	10.0 mPa·s	ST,+00010.00mPs	The digit of 0.01mPa·s is always zero.
	100 mPa·s	ST,+00100.00mPs	The digits of 0.01mPa·s and 0.1mPa·s are always zero.
	1.00 Pa·s	ST,+01000.00mPs	For 1000mPa·s or greater, the displayed unit is Pa·s, but the output unit remains mPa·s. The digits of 0.01mPa·s, 0.1mPa·s and 1mPa·s are always zero.
	H Pa·s	OL,+99999999mPs	Above measuring range error
Pa·s	L Pa·s	OL,-99999999Pas	Below measuring range error
	0.0003 Pa·s	ST,+000.0003Pas	
	0.0100 Pa·s	ST,+000.0100Pas	
	0.100 Pa·s	ST,+000.1000Pas	The digit of 0.0001Pa·s is always zero.
	1.00 Pa·s	ST,+001.0000Pas	The digits of 0.0001Pa·s and 0.001Pa·s are always zero.
	H Pa·s	OL,+99999999Pas	Above measuring range error
cP	L cP	OL,-99999999┘CP	Below measuring range error
	0.30 cP	ST,+00000.30┘CP	
	10.0 cP	ST,+00010.00┘CP	The digit of 0.01cP is always zero.
	100 cP	ST,+00100.00┘CP	The digits of 0.01cP and 0.1cP are always zero.
	10.0 P	ST,+01000.00┘CP	For 1000 cP or greater, the displayed unit is P, but the output unit remains cP. The digits of 0.01cP, 0.1cP and 1cP are always zero.
	H P	OL,+99999999┘CP	Above measuring range error
P	L P	OL,-99999999┘┘P	Below measuring range error
	0.0030 P	ST,+000.0030┘┘P	
	0.100 P	ST,+000.1000┘┘P	The digit of 0.0001P is always zero.
	1.00 P	ST,+001.0000┘┘P	The digits of 0.0001P and 0.001P are always zero.
	10.0 P	ST,+010.0000┘┘P	The digits of 0.0001P, 0.001P and 0.01P are always zero.
	H P	OL,+99999999┘┘P	Above measuring range error

┘ : Space (ASC 20h)

### SV-100A/SV-100H output format example

Viscosity unit	Display	Output format	Remarks
mPa·s	L Pa·s	OL, -99999999PaS	Below measuring range error
	1.00 Pa·s	ST, +00001.00PaS	
	10.0 Pa·s	ST, +00010.00PaS	The digit of 0.01Pa·s is always zero.
	H Pa·s	OL, +99999999PaS	Above measuring range error
P	L P	OL, -99999999┐P	Below measuring range error
	10.0 P	ST, +000010.0┐P	
	100 P	ST, +000100.0┐P	The digit of 0.1P is always zero.
	H P	OL, +99999999┐P	Above measuring range error

┐ : Space (ASC 20h)

### D.P. format

Used with the printer MODE 3 when the optional compact printer AD-8121B is connected.

With "Prt 0" or "Prt 1" selected for "Data output mode (Prt)", output contents can be selected by the settings of "S-Rt", "S-td" and "S-Ed".

With "Prt 2" selected for "Data output mode (Prt)", only the viscosity value is output

Shown below are SV-10A/SV-10H printing examples.

#### Printing format example (1)

Function setting (√=Output Blank=No output)			
S-Rt	1	Measurement elapsed time	√
S-td	1	Date/time	√
S-Ed	2	Remarks	√
		Device ID information	√
		Signature	

①②③④⑤⑥⑦⑧⑨⑩⑪⑫⑬⑭⑮⑯			
	A&D	←	Device ID information
MODEL	SV10A/H	←	Manufacturer
S/N	1480000	←	Model
ID	LAB-12	←	Serial number
- - - - -	- - - - -	←	ID number
	00:12:34	←	Measurement elapsed time
	25.6 C	←	Sample temperature
	12.3 mPa s	←	Viscosity
DATE	2003/03/31	←	Date (*)
TIME	12:34:56	←	Time
REMARKS		←	Remarks
- - - - -	- - - - -		
SIGNATURE		←	Signature
- - - - -	- - - - -		

#### Printing format example (2)

Function setting (√=Output Blank=No output)			
S-Rt	1	Measurement elapsed time	√
S-td	1	Date/time	√
S-Ed	1	Remarks	√
		Device ID information	
		Signature	

①②③④⑤⑥⑦⑧⑨⑩⑪⑫⑬⑭⑮⑯			
	00:12:34	←	Measurement elapsed time
	25.6 C	←	Sample temperature
	12.3 mPa s	←	Viscosity
DATE	2003/03/31	←	Date (*)
TIME	12:34:56	←	Time
REMARKS		←	Remarks
- - - - -	- - - - -		

### Printing format example (3)

Function setting (√=Output Blank=No output)		
S-Rt	1	Measurement elapsed time
S-td	1	Date/time
S-Ed	0	Remarks
		Device ID information
		Signature

①	②	③	④	⑤	⑥	⑦	⑧	⑨	⑩	⑪	⑫	⑬	⑭	⑮	⑯

(\*) The displaying order of the date (YMD/DMY/MDY) depends on the setting of "Date/Time (CLAdd)".

### Printing format example (4)

Function setting (√=Output Blank=No output)		
S-Rt	1	Measurement elapsed time
S-td	0	Date/time
S-Ed	0	Remarks
		Device ID information
		Signature

①	②	③	④	⑤	⑥	⑦	⑧	⑨	⑩	⑪	⑫	⑬	⑭	⑮	⑯

### Printing format example (5)

Function setting (√=Output Blank=No output)		
S-Rt	0	Measurement elapsed time
S-td	0	Date/time
S-Ed	0	Remarks
		Device ID information
		Signature

①	②	③	④	⑤	⑥	⑦	⑧	⑨	⑩	⑪	⑫	⑬	⑭	⑮	⑯

### CSV format

Appropriate when a personal computer is used to collect data. Measurement values are output in comma separated format.

With "S-td" setting, the date and time can be added to the measurement data.

When a comma is selected as the decimal point by "Pnt 1", a semicolon ";" is used as a data separator.

With CSV format selected, the viscosity value and the temperature are output using the internal resolution.

The relation between the measuring unit and the internal resolution is as follows:

	Model	Viscosity				Temperature	
		mPa·s	Pa·s	cP	P	°C	°F
Internal resolution	SV-1A/SV-1H SV-10A/SV-10H	0.01	0.0001	0.01	0.0001	0.01	0.01
	SV-100A SV-100H	-	0.01	-	0.1		

### Output format example (1) With ID number, date and time added

Function setting (√=Output Blank=No output)			
S-E d	1	Date/time	√
S-E d	3	Device ID number	√

Outputs in the order of ID number, date, time, temperature, temperature unit, viscosity and viscosity unit.

The output data are 52 characters long excluding the terminator.

### SV-1A/SV-1H output format example

Viscosity / Temperature	Display	Output format example	Remarks
mPa·s / °C	L mPa·s	LAB-12,2003/03/19,12:34:56,+025.67,C,+00000.00,mPa <u>s</u>	Zeroes are output for below measuring range error.
	0.30mPa·s	LAB-12,2003/03/19,12:34:56,+025.67,C,+00000.30,mPa <u>s</u>	
	10.0 mPa·s	LAB-12,2003/03/19,12:34:56,+025.67,C,+00010.00,mPa <u>s</u>	
	100 mPa·s	LAB-12,2003/03/19,12:34:56,+025.67,C,+00100.00,mPa <u>s</u>	
	1.00 Pa·s	LAB-12,2003/03/19,12:34:56,+025.67,C,+01000.00,mPa <u>s</u>	For 1000 mPa·s or greater, the displayed unit is Pa·s, but the output unit remains mPa·s.
	H Pa·s	LAB-12,2003/03/19,12:34:56,+025.67,C,+01200.00,mPa <u>s</u>	1200 is output for above measuring range error.
Pa·s / °F	L Pa·s	LAB-12,2003/03/19,12:34:56,+051.23,F,+000.0000, <u>Pa</u> s	Zeroes are output for below measuring range error.
	0.0003 Pa·s	LAB-12,2003/03/19,12:34:56,+051.23,F,+000.0003, <u>Pa</u> s	
	0.0100 Pa·s	LAB-12,2003/03/19,12:34:56,+051.23,F,+000.0100, <u>Pa</u> s	
	0.100 Pa·s	LAB-12,2003/03/19,12:34:56,+051.23,F,+000.1000, <u>Pa</u> s	
	1.00 Pa·s	LAB-12,2003/03/19,12:34:56,+051.23,F,+001.0000, <u>Pa</u> s	
	H Pa·s	LAB-12,2003/03/19,12:34:56,+051.23,F,+001.2000, <u>Pa</u> s	1.2 is output for above measuring range error.
cP / °C	L cP	LAB-12,2003/03/19,12:34:56,+025.67,C,+000.0000, <u>cP</u>	Zeroes are output for below measuring range error.
	0.30 cP	LAB-12,2003/03/19,12:34:56,+025.67,C,+00000.30, <u>cP</u>	
	10.0 cP	LAB-12,2003/03/19,12:34:56,+025.67,C,+00010.00, <u>cP</u>	
	100 cP	LAB-12,2003/03/19,12:34:56,+025.67,C,+00100.00, <u>cP</u>	
	10.0 P	LAB-12,2003/03/19,12:34:56,+025.67,C,+01000.00, <u>cP</u>	For 1000 cP or greater, the displayed unit is P, but the output unit remains cP.
	H P	LAB-12,2003/03/19,12:34:56,+025.67,C,+01200.00, <u>cP</u>	1200 is output for above measuring range error.
P / °F	L P	LAB-12,2003/03/19,12:34:56,+051.23,F,+000.0000, <u>P</u>	Zeroes are output for below measuring range error.
	0.0030 P	LAB-12,2003/03/19,12:34:56,+051.23,F,+000.0030, <u>P</u>	
	0.100 P	LAB-12,2003/03/19,12:34:56,+051.23,F,+000.1000, <u>P</u>	
	1.00 P	LAB-12,2003/03/19,12:34:56,+051.23,F,+001.0000, <u>P</u>	
	10.0 P	LAB-12,2003/03/19,12:34:56,+051.23,F,+010.0000, <u>P</u>	
	H P	LAB-12,2003/03/19,12:34:56,+051.23,F,+012.0000, <u>P</u>	12 is output for above measuring range error.

␣ : Space (ASC 20h)

**SV-10A/SV-10H output format example**

Viscosity / Temperature	Display	Output format example	Remarks
mPa·s / °C	L mPa·s	LAB-12, 2003/03/19, 12:34:56, +025.67, C, +00000.00, mPa <u>s</u>	Zeroes are output for below measuring range error.
	0.30mPa·s	LAB-12, 2003/03/19, 12:34:56, +025.67, C, +00000.30, mPa <u>s</u>	
	10.0 mPa·s	LAB-12, 2003/03/19, 12:34:56, +025.67, C, +00010.00, mPa <u>s</u>	
	100 mPa·s	LAB-12, 2003/03/19, 12:34:56, +025.67, C, +00100.00, mPa <u>s</u>	
	1.00 Pa·s	LAB-12, 2003/03/19, 12:34:56, +025.67, C, +01000.00, mPa <u>s</u>	For 1000 mPa·s or greater, the displayed unit is Pa·s, but the output unit remains mPa·s.
	H Pa·s	LAB-12, 2003/03/19, 12:34:56, +025.67, C, +12000.00, mPa <u>s</u>	12000 is output for above measuring range error.
Pa·s / °F	L Pa·s	LAB-12, 2003/03/19, 12:34:56, +051.23, F, +000.0000, <u>Pa</u> Pa <u>s</u>	Zeroes are output for below measuring range error.
	0.0003 Pa·s	LAB-12, 2003/03/19, 12:34:56, +051.23, F, +000.0003, <u>Pa</u> Pa <u>s</u>	
	0.0100 Pa·s	LAB-12, 2003/03/19, 12:34:56, +051.23, F, +000.0100, <u>Pa</u> Pa <u>s</u>	
	0.100 Pa·s	LAB-12, 2003/03/19, 12:34:56, +051.23, F, +000.1000, <u>Pa</u> Pa <u>s</u>	
	1.00 Pa·s	LAB-12, 2003/03/19, 12:34:56, +051.23, F, +001.0000, <u>Pa</u> Pa <u>s</u>	
	H Pa·s	LAB-12, 2003/03/19, 12:34:56, +051.23, F, +012.0000, <u>Pa</u> Pa <u>s</u>	12 is output for above measuring range error.
cP / °C	L cP	LAB-12, 2003/03/19, 12:34:56, +025.67, C, +000.0000, <u>cP</u> Pa <u>s</u>	Zeroes are output for below measuring range error.
	0.30 cP	LAB-12, 2003/03/19, 12:34:56, +025.67, C, +00000.30, <u>cP</u> Pa <u>s</u>	
	10.0 cP	LAB-12, 2003/03/19, 12:34:56, +025.67, C, +00010.00, <u>cP</u> Pa <u>s</u>	
	100 cP	LAB-12, 2003/03/19, 12:34:56, +025.67, C, +00100.00, <u>cP</u> Pa <u>s</u>	
	10.0 P	LAB-12, 2003/03/19, 12:34:56, +025.67, C, +01000.00, <u>cP</u> Pa <u>s</u>	For 1000 cP or greater, the displayed unit is P, but the output unit remains cP.
	H P	LAB-12, 2003/03/19, 12:34:56, +025.67, C, +12000.00, <u>cP</u> Pa <u>s</u>	12000 is output for above measuring range error.
P / °F	L P	LAB-12, 2003/03/19, 12:34:56, +051.23, F, +000.0000, <u>P</u> Pa <u>s</u>	Zeroes are output for below measuring range error.
	0.0030 P	LAB-12, 2003/03/19, 12:34:56, +051.23, F, +000.0030, <u>P</u> Pa <u>s</u>	
	0.100 P	LAB-12, 2003/03/19, 12:34:56, +051.23, F, +000.1000, <u>P</u> Pa <u>s</u>	
	1.00 P	LAB-12, 2003/03/19, 12:34:56, +051.23, F, +001.0000, <u>P</u> Pa <u>s</u>	
	10.0 P	LAB-12, 2003/03/19, 12:34:56, +051.23, F, +010.0000, <u>P</u> Pa <u>s</u>	
	H P	LAB-12, 2003/03/19, 12:34:56, +051.23, F, +120.0000, <u>P</u> Pa <u>s</u>	120 is output for above measuring range error.

␣ : Space (ASC 20h)



### SV-100A/SV-100H output format example

Viscosity / Temperature	Display	Output format example	Remarks
Pa·s / °C	L Pa·s	LAB-12,2003/03/19,12:34:56,+025.67,C,+00000.00,␣Pa␣S	Zeroes are output for below measuring range error.
	1.00 Pa·s	LAB-12,2003/03/19,12:34:56,+025.67,C,+00001.00,␣Pa␣S	
	10.0 Pa·s	LAB-12,2003/03/19,12:34:56,+025.67,C,+00010.00,␣Pa␣S	
	H Pa·s	LAB-12,2003/03/19,12:34:56,+025.67,C,+00120.00,␣Pa␣S	120 is output for above measuring range error.
P / °F	L P	LAB-12,2003/03/19,12:34:56,+051.23,F,+000000.0,␣P␣F	Zeroes are output for below measuring range error.
	10.0 P	LAB-12,2003/03/19,12:34:56,+051.23,F,+000010.0,␣P␣F	
	100 P	LAB-12,2003/03/19,12:34:56,+051.23,F,+000100.0,␣P␣F	
	H P	LAB-12,2003/03/19,12:34:56,+051.23,F,+001200.0,␣P␣F	1200 is output for above measuring range error.

␣ : Space (ASC 20h)

### Output format example (2) With date and time added

Function setting (√=Output Blank=No output)			
S-E d	/	Date/time	√
S-E d	0	Device ID number	

Outputs in the order of date, time, temperature, temperature unit, viscosity and viscosity unit.

The output data are 46 characters long excluding the terminator.

### SV-1A/SV-1H/SV-10A/SV-10H output format example

Viscosity / Temperature	Display	Output format example
mPa·s / °C	1.23 mPa·s	,2003/03/19,12:34:56,+025.67,C,+00001.23,mPa␣S

␣ : Space (ASC 20h)

### SV-100A/SV-100H output format example

Viscosity / Temperature	Display	Output format example
Pa·s / °C	1.23 Pa·s	,2003/03/19,12:34:56,+025.67,C,+00001.23,␣Pa␣S

␣ : Space (ASC 20h)

### Output format example (3) To output the measured temperature and viscosity only

Function setting (√=Output Blank=No output)			
S-E d	0	Date/time	
S-E d	0	Device ID number	

Outputs in the order of temperature, temperature unit, viscosity and viscosity unit.

The output data are 28 characters long excluding the terminator.

### SV-1A/SV-1H/SV-10A/SV-10H output format example

Viscosity / Temperature	Display	Output format example
mPa·s / °C	1.23 mPa·s	,, ,+025.67,C,+00001.23,mPa␣s

␣ : Space (ASC 20h)

### SV-100A/100H output format example

Viscosity / Temperature	Display	Output format example
Pa·s / °C	1.23 Pa·s	,, ,+025.67,C,+00001.23,␣Pa␣s

␣ : Space (ASC 20h)

### RsVisco format

Used with the graphing program RsVisco. Measurement data are output in comma separated format. When a comma is selected as the decimal point by "Print 1", a semicolon ";" is used as a data separator.

When a measurement is started using RsVisco, the viscometer automatically selects this format.

Measurement data are output in the order of viscosity, viscosity unit, temperature and temperature unit.

The output data are 25 characters long excluding the terminator

With RsVisco format selected, the viscosity value and the temperature are output using the internal resolution.

The relation between the measuring unit and the internal resolution is as follows:

	Model	Viscosity				Temperature	
		mPa·s	Pa·s	cP	P	°C	°F
Internal resolution	SV-1A/SV-1H SV-10A/SV-10H	0.01	0.0001	0.01	0.0001	0.01	0.01
	SV-100A SV-100H	–	0.01	–	0.1		

### SV-1A/SV-1H output format example

Viscosity / Temperature	Display	Output format example	Remarks
mPa·s / °C	L mPa·s	+00000.00, mPa <u> </u> s, +025.67, C	Zeroes are output for below measuring range error.
	0.30 mPa·s	+00000.30, mPa <u> </u> s, +025.67, C	
	10.0 mPa·s	+00010.00, mPa <u> </u> s, +025.67, C	
	100 mPa·s	+00100.00, mPa <u> </u> s, +025.67, C	
	1.00 Pa·s	+01000.00, mPa <u> </u> s, +025.67, C	For 1000 mPa-s or greater, the displayed unit is Pa-s, but the output unit remains mPa-s.
	H Pa·s	+01200.00, mPa <u> </u> s, +025.67, C	1200 is output for above measuring range error.
Pa·s / °F	L Pa·s	+000.0000, <u> </u> Pa <u> </u> s, +051.23, F	Zeroes are output for below measuring range error.
	0.0003 Pa·s	+000.0003, <u> </u> Pa <u> </u> s, +051.23, F	
	0.0100 Pa·s	+000.0100, <u> </u> Pa <u> </u> s, +051.23, F	
	0.100 Pa·s	+000.1000, <u> </u> Pa <u> </u> s, +051.23, F	
	1.00 Pa·s	+001.0000, <u> </u> Pa <u> </u> s, +051.23, F	
	H Pa·s	+001.2000, <u> </u> Pa <u> </u> s, +051.23, F	1.2 is output for above measuring range error.
cP / °C	L cP	+000.0000, <u> </u> cP <u> </u> , +025.67, C	Zeroes are output for below measuring range error.
	0.30 cP	+00000.30, <u> </u> cP <u> </u> , +025.67, C	
	10.0 cP	+00010.00, <u> </u> cP <u> </u> , +025.67, C	
	100 cP	+00100.00, <u> </u> cP <u> </u> , +025.67, C	
	10.0 P	+01000.00, <u> </u> cP <u> </u> , +025.67, C	For 1000 cP or greater, the displayed unit is P, but the output unit remains cP.
	H P	+01200.00, <u> </u> cP <u> </u> , +025.67, C	1200 is output for above measuring range error.
P / °F	L P	+000.0000, <u> </u> P <u> </u> , +051.23, F	Zeroes are output for below measuring range error.
	0.0030 P	+000.0030, <u> </u> P <u> </u> , +051.23, F	
	0.100 P	+000.1000, <u> </u> P <u> </u> , +051.23, F	
	1.00 P	+001.0000, <u> </u> P <u> </u> , +051.23, F	
	10.0 P	+010.0000, <u> </u> P <u> </u> , +051.23, F	
	H P	+012.0000, <u> </u> P <u> </u> , +051.23, F	12 is output for above measuring range error.

  : Space (ASC 20h)

**SV-10A/SV-10H output format example**

Viscosity / Temperature	Display	Output format example	Remarks
mPa·s / °C	L mPa·s	+00000.00, mPa <u> </u> s, +025.67, C	Zeroes are output for below measuring range error.
	0.30 mPa·s	+00000.30, mPa <u> </u> s, +025.67, C	
	10.0 mPa·s	+00010.00, mPa <u> </u> s, +025.67, C	
	100 mPa·s	+00100.00, mPa <u> </u> s, +025.67, C	
	1.00 Pa·s	+01000.00, mPa <u> </u> s, +025.67, C	For 1000 mPa·s or greater, the displayed unit is Pa·s, but the output unit remains mPa·s.
	H Pa·s	+12000.00, mPa <u> </u> s, +025.67, C	12000 is output for above measuring range error.
Pa·s / °F	L Pa·s	+000.0000, <u> </u> Pa <u> </u> s, +051.23, F	Zeroes are output for below measuring range error.
	0.0003 Pa·s	+000.0003, <u> </u> Pa <u> </u> s, +051.23, F	
	0.0100 Pa·s	+000.0100, <u> </u> Pa <u> </u> s, +051.23, F	
	0.100 Pa·s	+000.1000, <u> </u> Pa <u> </u> s, +051.23, F	
	1.00 Pa·s	+001.0000, <u> </u> Pa <u> </u> s, +051.23, F	
	H Pa·s	+012.0000, <u> </u> Pa <u> </u> s, +051.23, F	12 is output for above measuring range error.
cP / °C	L cP	+000.0000, <u> </u> cP <u> </u> , +025.67, C	Zeroes are output for below measuring range error.
	0.30 cP	+00000.30, <u> </u> cP <u> </u> , +025.67, C	
	10.0 cP	+00010.00, <u> </u> cP <u> </u> , +025.67, C	
	100 cP	+00100.00, <u> </u> cP <u> </u> , +025.67, C	
	10.0 P	+01000.00, <u> </u> cP <u> </u> , +025.67, C	For 1000 cP or greater, the displayed unit is P, but the output unit remains cP.
	H P	+12000.00, <u> </u> cP <u> </u> , +025.67, C	12000 is output for above measuring range error.
P / °F	L P	+000.0000, <u> </u> P <u> </u> , +051.23, F	Zeroes are output for below measuring range error.
	0.0030 P	+000.0030, <u> </u> P <u> </u> , +051.23, F	
	0.100 P	+000.1000, <u> </u> P <u> </u> , +051.23, F	
	1.00 P	+001.0000, <u> </u> P <u> </u> , +051.23, F	
	10.0 P	+010.0000, <u> </u> P <u> </u> , +051.23, F	
	H P	+120.0000, <u> </u> P <u> </u> , +051.23, F	120 is output for above measuring range error.

  : Space (ASC 20h)

**SV-100A/SV-100H output format example**

Viscosity / Temperature	Display	Output format example	Remarks
Pa·s / °C	L Pa·s	+0000.000, <u> </u> Pa <u> </u> s, +025.67, C	Zeroes are output for below measuring range error.
	1.00 Pa·s	+00001.00, <u> </u> Pa <u> </u> s, +025.67, C	
	10.0 Pa·s	+00010.00, <u> </u> Pa <u> </u> s, +025.67, C	
	H Pa·s	+00120.00, <u> </u> Pa <u> </u> s, +025.67, C	120 is output for above measuring range error.
P / °F	L P	+000000.0, <u> </u> P <u> </u> , +051.23, F	Zeroes are output for below measuring range error.
	10.0 P	+000010.0, <u> </u> P <u> </u> , +051.23, F	
	100 P	+000100.0, <u> </u> P <u> </u> , +051.23, F	
	H P	+001200.0, <u> </u> P <u> </u> , +051.23, F	1200 is output for above measuring range error.

  : Space (ASC 20h)

# 11. CONNECTION TO A PERSONAL COMPUTER

## 11-1 Introduction

If connecting the SV-A / SV-H series to a personal computer using the Windows communication tools WinCT-Viscosity (CD-ROM), the measurement data can be imported into the personal computer.

The graphing program RsVisco that is contained in the Windows communication tools WinCT-Viscosity has following features.

- This program can display a graph of the sample viscosity changing in real time. At this time, the sample temperature is imported into the personal computer. Therefore you can easily understand the sample characteristic by displaying a graph of the relation between the temperature and viscosity.
  - During continuous measurement, you can compare the sample characteristic by displaying a graph on a graph.
  - The measurement data can be saved as the CSV file in the personal computer. The input data can be displayed as a graph again.
  - The graph data can be printed with a printer that is connected to the personal computer.
- \* For measurement examples, refer to the sample measurement collection. For details of how to use the WinCT-Viscosity, refer to "Readme" that is installed in the personal computer after the CD-ROM setup.

### For the SV-A series

The software set that is necessary to connect a personal computer is a standard accessory. Therefore, the viscometer can be connected to a personal computer at once.

### For the SV-H series

Use the AX-SV-53-EX (software set, sold separately).

#### The AX-SV-53-EX Software set package contents

- Windows communication tools "WinCT-Viscosity"(CD-ROM) 1 pc
- RS-232C straight cable 1 pc
- Serial-USB converter 1 pc

## 11-2 Installation of WinCT-Viscosity

Refer to "\English\ReadMe.txt" in the CD-ROM, to install WinCT-Viscosity in a personal computer.

## 11-3 Connection to a Personal Computer

### In a case that the personal computer has a COM port

The SV-A / SV-H series can be connected to a personal computer using the RS-232C cable.

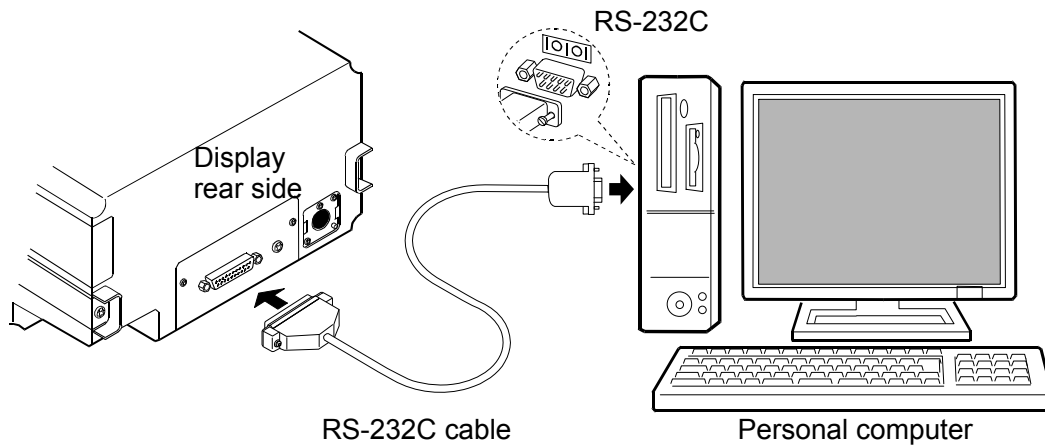

### In a case that the personal computer does not have a COM port (Example: notebook type etc)

By using the standard serial-USB converter provided, a personal computer can increase the number of COM ports available. Therefore, the SV-A / SV-H series can be connected to a personal computer using the RS-232C cable.

#### Setting up

- 1 Connect the serial-USB converter to the personal computer. Install the driver of the serial-USB converter in the personal computer. Refer to the instruction manual of the serial-USB converter.
- 2 Connect the serial-USB converter to the SV-A / SV-H series by using the RS-232C cable.

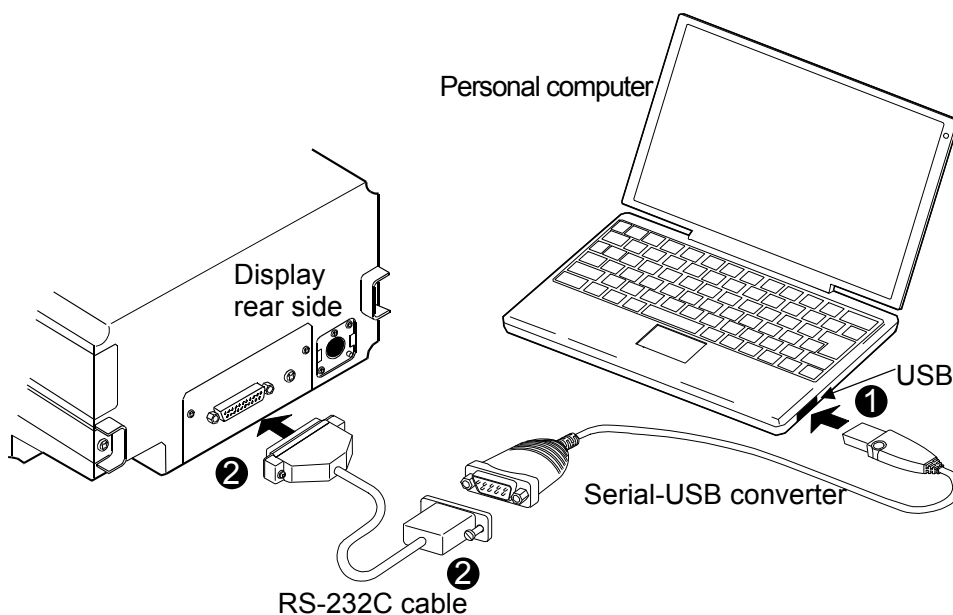

## 11-4 Configuration of the COM Port

When connecting the SV-A / SV-H series to a personal computer, confirm that the COM port setting is correct.

### (1) Configuring the COM port

- 1 Click the **START** bottom → the “Setting” → the “Control panel”.
- 2 Double-click the “System” .
- 3 Click the “Hardware” Tab, and click the “Device Manager” .
- 4 Double-click the “Port (COM and LPT)” to display the number of the COM port. When the serial-USB converter is used, “ATEN USB to Serial Bridge (CM4)” is displayed. With this example, the COM port is set to “4”.

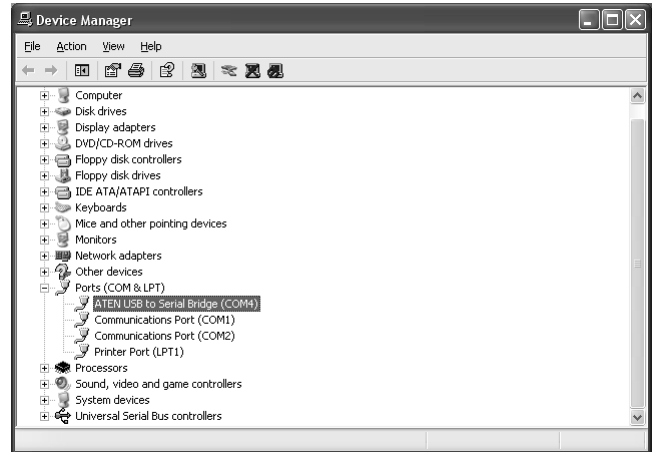

Confirming the COM ports with the Device Manager  
(Example: The COM port of the USB converter is set to “4”.)

The COM port of the personal computer is displayed as “Communications Port (COM1)”.

With this example, the personal computer has two COM ports and they are displayed as Communications Port (COM1) and Communications Port (COM2).

Confirm the COM port number into which the connection is performed.

### (2) Setting the COM port (Example: graphing software “RsVisco”)

- 1 Click the **START** bottom → the “Program” → the “A&D WinCT-Viscosity” → the “RSVisco”.
- 2 Click “RS-232C (R)” of menu → the “COM Port (C)”, and set the COM port that is confirmed in “(1) Configuring the COM port”.

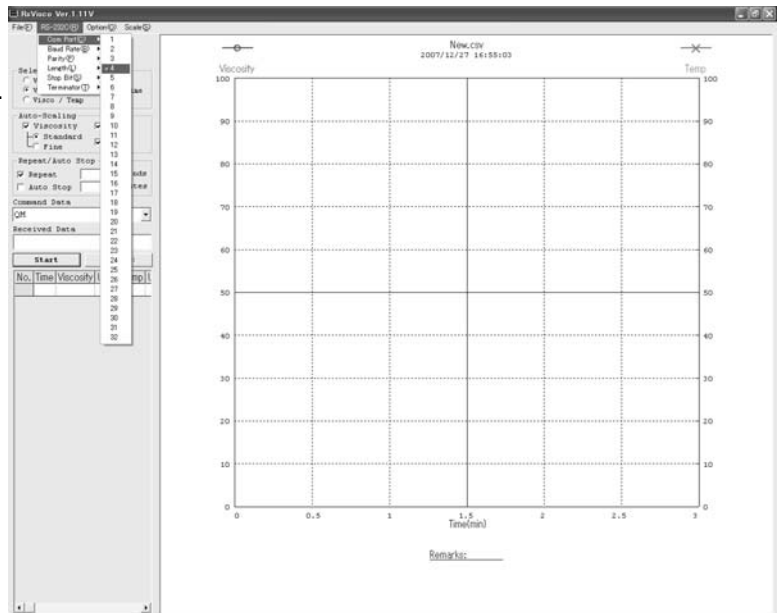

Setting the COM port with the RsVisco  
(Example: The COM port is set to “4”.)

## 11-5 Controlling the Measurement Using a Personal Computer

---

(In case of the graphing software “RsVisco”)

- 1 Refer to “6. MEASUREMENT” to prepare for the measurement.
  - 2 Start the graphing software “RsVisco”.
  - 3 Confirm that the COM port of the “RsVisco” is set properly.
  - 4 Click the  button of the “RsVisco” to start the measurement.
  - 5 If you want to finish the measurement, click the  button of the “RsVisco”.
- \* For details on how to use the software, refer to the “Readme” file that is installed in a personal computer after the CD-ROM setup.



# CONNECTION TO A PRINTER (FOR ALL MODELS)

- The viscometer can be connected to the optional compact printer AD-8121B using the standard RS-232C interface and the measurement results can be printed.
- The statistical calculation data of the results and the changes in the viscosity value per a certain time can be printed using the function of the AD-8121B.
- Use the AD-8121B accessory cable to connect the printer to the viscometer.

## Setting List

What to print	Viscometer function settings						AD-8121B settings
	<i>Prt</i>	<i>TYPE</i>	<i>S-Rt</i>	<i>S-td</i>	<i>S-Ed</i>	<i>PUSE</i>	
Measurement results	0 <sup>*</sup> , 1	1 <sup>*</sup>	0, 1 <sup>*</sup>	0, 1 <sup>*</sup>	0, 1, 2 <sup>*</sup>	1 <sup>*</sup>	MODE 3

- Factory setting

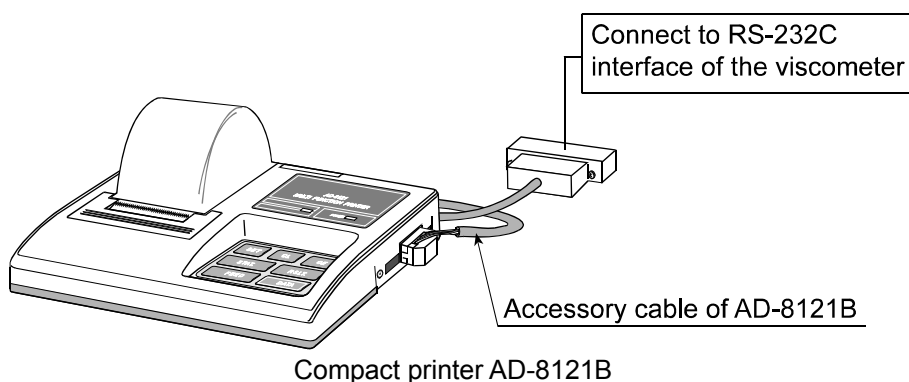

## Note

### AD-8121B settings

Mode	AD-8121B DIP switches	Description
Mode 1		Prints upon data receipt Standard mode, statistical calculation mode
Mode 2		Prints using the AD-8121B DATA key or the AD-8121B built-in timer Standard mode, interval mode, chart mode
Mode 3		Prints upon data receipt Dump print mode

DIP switch 3: Handling unstable data

ON = To print unstable data

OFF = Not to print unstable data

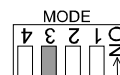

DIP switch 4: Data input specification

ON = Use the current loop

OFF = Use the RS-232C

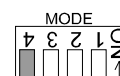

# 12. RS-232C SERIAL INTERFACE (FOR ALL MODELS)

## RS-232C Serial Interface

Transmission system EIA RS-232C  
 Transmission form Asynchronous, bi-directional, half duplex  
 Data format Baud rate 2400 bps  
 Data bits 7 bits  
 Parity EVEN  
 Stop bit 1 bit  
 Code ASCII  
 Terminator CR LF (CR: 0Dh, LF: 0Ah)

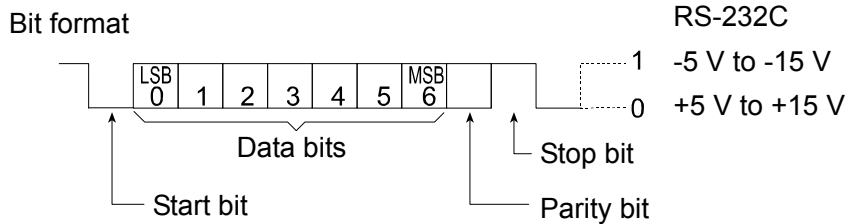

## Pin Connections

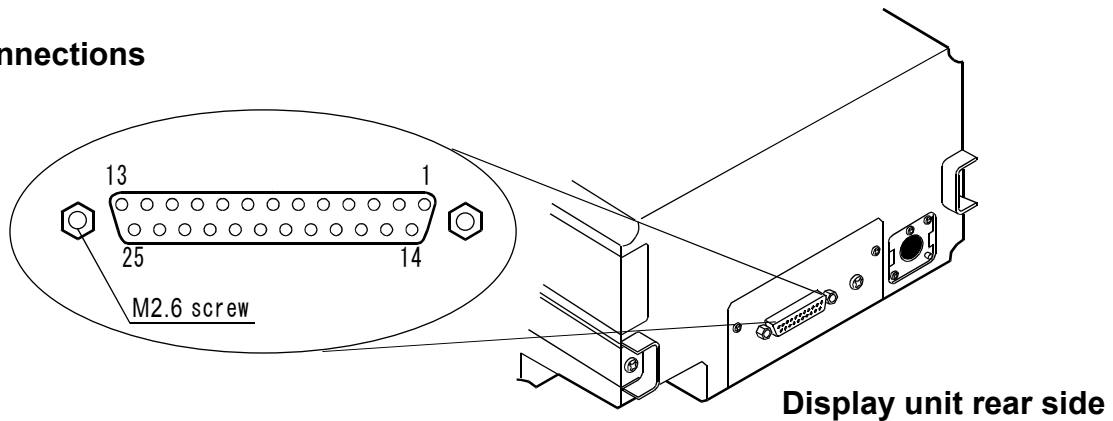

Pin No.	SV-A/H series (DCE)		Computer (DTE)	
	Signal Name *1	Description	Direction	Signal Name
1	FG	Frame ground	-	FG
2	RXD	Receive data	←	TXD
3	TXD	Transmit data	→	RXD
4	RTS	Ready to send *2	←	RTS
5	CTS	Clear to send *2	→	CTS
6	DSR	Data set ready	→	DSR
7	SG	Signal ground	-	SG
16, 18, 19, 21, 23	Internal use		Do not connect *3	
Others	Not used			

\*1: Signal names of the viscometer side are the same as the DTE side with TXD and RXD reversed.

\*2: RTS and CTS flow control are not used. CTS output is HI always.

\*3: Normal DOS/V cables do not use these terminals.

## 13. COMMAND LIST (FOR ALL MODELS)

The viscometer can be controlled by the following commands from the computer.

Add a terminator  $\text{C}_R\text{L}_F$  ( 0Dh, 0Ah ) to each command.

Command	Description
Q	Outputs the current data. (This is effective whether not measurement being carried out.)
SIR	Outputs data continuously
C	Stops data output by SIR command.
QM	Outputs the data during measurement. (This is effective only while measurement is being carried out.)
START	Same as the $\text{START}$ key
STOP	Same as the $\text{STOP}$ key
HOLD	Same as the $\text{HOLD}$ key
MODE	Same as the $\text{MODE}$ key
PRINT	Same as the $\text{PRINT}$ key

## 14. TROUBLESHOOTING (FOR ALL MODELS)

The viscometer is a precision instrument. When the operating environment or the operating method is inadequate, correct values cannot be obtained. If measurement values do not become stable or they seem to be incorrect, check as described below. If improper performance persists after checking, contact the local A&D dealer for repair.

### 14-1 When Measurement Values do not Become Stable (For all models)

- ✓ Is the ambient environment free from vibration and drafts?
  - Places such as second or higher floor or near busy highways or rail lines are prone to vibration.  
Avoid these places or use an anti-vibration table, AD-1671A.
  - Reconsider the setting of "Condition (Cond)" of the function setting.  
Set it to "Cond 2".
  - Avoid direct drafts in the vicinity of the viscometer.
- ✓ Is there a strong electrical or magnetic noise source such as a motor near the viscometer?
  - Install the viscometer away from the electrical or magnetic noise sources
- ✓ With the SV-1A/SV-1H, if the sensor plate touches the inner wall of the 2 mL cup, the displayed value will not stabilize. Adjust the spacing between the sensor plate and the inner wall of the 2 mL cup.
- ✓ Is the protector or the sensor protective cover in contact with the sensor plates or the temperature sensor?
  - Attach the protector and the sensor protective cover properly so that they do not touch the sensor plates or the temperature sensor.
  - Remove the protector, the surface locator plate or the sensor protective cover when necessary.

#### (1) How to remove the protector (For all models)

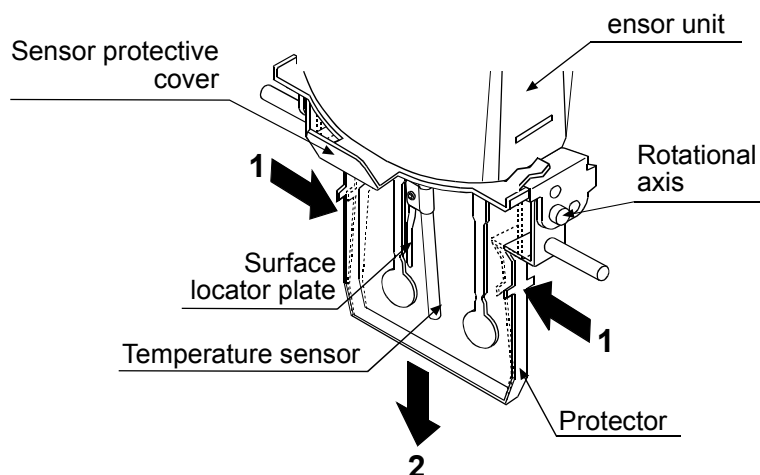

Press the left and right side frames lightly in the direction indicated as **1** to release the rotational axes. Pull the protector in the direction indicated as **2** to remove.

## (2) How to remove and attach the surface locator plate (Only for the SV-10A/SV-10H/SV-100A/SV-100H)

### Removing

Loosen the screw and remove the surface locator plate from the temperature sensor.

### Attaching

Install the surface locator plate as shown in the illustration. Slip the locator plate onto the temperature sensor. Move the plate to the top of the sensor. Adjust the position of the locator plate so that the tip of the locator plate aligns to the center of the narrow part of the sensor plates.

Tighten the screw.

### **Note**

**When the sensor plate and the surface locator plate are too close, a measurement error may occur due to the liquid surface tension. Therefore, secure a clearance of at least 1 mm between the sensor plate and the surface locator plate. Maintain the clearance by rotating the surface locator plate when necessary.**

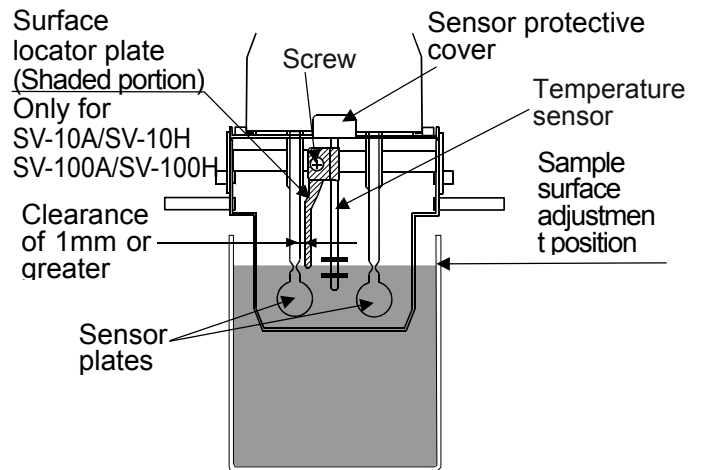

## (3) How to remove the sensor protective cover (For all models)

Remove the protector and the surface locator plate.

Pull the sensor protective cover in the direction indicated as **1** to release the portions **A** (two) and **B** from the protector frame.

Pull the sensor protective cover in the direction indicated as **2** to remove.

### **Note**

**When removing the sensor protective cover, it may touch the sensor plates and the temperature sensor. Use much care not to damage them.**

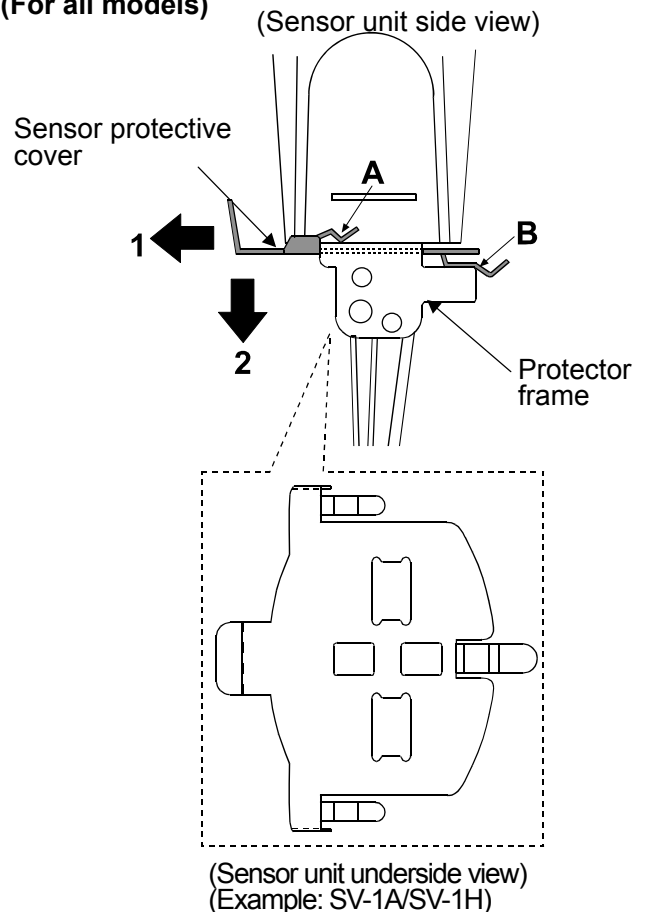

## 14-2 When Measurement Values are not Correct (For all models)

---

✓ Is the viscometer in the data hold mode?

- To release the data hold mode, press the **HOLD** key.
- The processing indicator blinks while a measurement is performed.

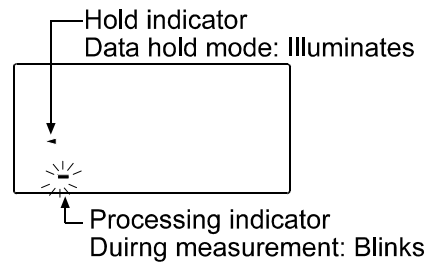

✓ Has the sample surface been adjusted to the center of the narrow part of the sensor plates?

- Adjust the table height by turning the knob so that the center of the narrow part of the sensor plates is on the sample surface.

✓ Are the positions of the left and right sensor plates in the sample surface the same?

- If not the same, level the viscometer using the leveling feet so that the liquid surface will be leveled.

✓ Are the sensor plates clean?

- Remove any residual sample material from the sensor plates using alcohol.
- When any residual sample material is on the portion of the sensor plates above the sample surface, changes in the mass cause the vibration frequency to shift, which will result in a measurement error.

✓ Are the sensor plates bent?

- If bent, contact the local A&D dealer for repair.

✓ Does the sample generate bubbles because of the differences in the sample temperature and the ambient temperature and do the bubbles stick to the sensor plates?

✓ The sample viscosity depends on the temperature.

- In general, because the viscosity of a liquid depends on its temperature, the viscosity value decreases about 2 to 10 percent per degree Celsius if increasing the temperature.

✓ Is the sample surface lowered?

- In a measurement that takes a long time, evaporation may cause the sample surface to be lowered. Maintain the sample surface level.

✓ Do the main unit and the display unit have the same serial number?

- The main unit and the display unit have been adjusted in pairs. Confirm that the main unit and the display unit have the same serial number.

✓ Is calibration performed?

- When the absolute viscosity value is important, it is recommend that a periodic calibration be performed using a standard viscosity fluid.

- ✓ Influence caused by sample cups

The viscometers have been calibrated with the following cups when shipped. When using other cups, calibrate the viscometer using the sample cup that will be used for measurement and then measure the viscosity.

SV-1A/SV-1H

Sample cup (Capacity: 2 mL)

SV-10A/SV-10H/SV-100A/SV-100H Sample cup (Capacity: 45 mL)

#### **Note**

**The SV-10A/SV-10H/SV-100A/SV-100H has been calibrated with the protector attached when shipped. Please note that the value, obtained when the viscometer is calibrated without the protector, may be different from that upon shipment.**

## **14-3 When More Precise Measurement is Required: (For all models)**

---

- ✓ When the viscometer is installed for the first time or is moved to another location, plug in the AC adapter and warm up the viscometer for one hour or more, to acclimatize the viscometer to the measuring environment.  
And before measurement, calibrate the viscometer using the sample cup that will be used for measurement.
- ✓ Placing the sensor plates and the temperature sensor in the sample may change the sample temperature. For precise measurement, leave the sample as is for a while, after placing the sensor plates and the temperature sensor, to ensure no changes to the sample temperature. And then, start a measurement.
- ✓ When the sensor plates and the temperature sensor are cleaned using alcohol, the plates and the sensor are cooled temporarily and their temperature is lowered. Allow the plates and the sensor to acclimatize to the measuring environment before measurement.

## **14-4 When the Temperature Values are not Correct (For all models)**

---

- ✓ Is the display unit connected to the main unit properly using the connection cable?
  - Make a connection between the display unit and the main unit.  
With the SV-A series, refer to page 12. With the SV-H series, refer to pages 14-15.

## **14-5 When Water Viscosity is to be Measured (Only for the SV-1A/1H/10A/10H)**



---

- ✓ When tap water is poured into the sample cup directly and is measured, bubbles are generated on the sensor plates due to the difference in pressure and temperature and the viscosity may increase gradually. Pressurized tap water generates bubbles easily. Therefore, use distilled or purified water that is not pressurized.

Leave the sensor plates and sample in the same environment to acclimatize before measuring, to decrease temperatures fluctuations.

- ✓ In a measurement that takes a long time, the sample viscosity may increase due to water contamination. Perform a periodic check on water quality.

## 15. ERROR DISPLAY (FOR ALL MODELS)

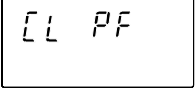
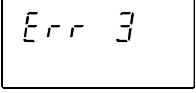
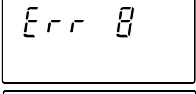
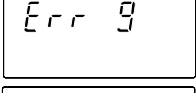
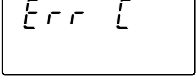
Error display	Description
	<p>Above measuring range error The viscosity value exceeds the upper limit of the viscosity measuring range (SV-1A/SV-1H: 1.19 Pa·s, SV-10A/SV-1H: 11.99 Pa·s, SV-100A/SV-100H: 119.9 Pa·s). The viscosity of the sample cannot be measured.</p> <p>This error may occur when the display unit is not connected to the main unit.</p>
	<p>Below measuring range error The viscosity value is below the lower limit of the viscosity measuring range (SV-1A/SV-1H/SV-10A/SV-10H: 0.30 mPa·s, SV-100A/SV-100H: 0.90 Pa·s) The viscosity of the sample cannot be measured.</p> <p>This error may occur when the display unit is not connected to the main unit.</p>
	<p>The power supply for the internal clock is depleted. Press any key to enter the clock correction mode. Setting the clock enables the viscometer to be used temporarily. If the error occurs frequently, contact the local A&amp;D dealer for repair.</p>
   	<p>Internal IC error Turn the power off. Then, turn the power on again. If this does not resolve the error, contact the local A&amp;D dealer for repair.</p>



# 16. SPECIFICATIONS

Measurement method	SV-1A/SV-1H	SV-10A/SV-10H	SV-100A/SV-100H		
Measurement method	Sine-wave Vibro Viscometer using the Tuning-fork Vibration method Vibration frequency 30 Hz				
Viscosity measuring range	0.3 to 1000 mPa·s	0.3 to 10000 mPa·s	1 to 100 Pa·s (1000 to 100000 mPa·s)		
Measurement accuracy *1	Repeatability *2	1% (Standard deviation)			
	Accuracy *3	±5% (1 to 100 mPa·s)	±3% (1 to 1000 mPa·s)	±5% (1 to 10 Pa·s) (1000 to 100000 mPa·s)	
Minimum display	Range (mPa·s)	Minimum display (mPa·s)	Minimum display (Pa·s)	Range (Pa·s)	Minimum display (Pa·s)
	0.3-10	0.01	0.0001	0.3-10	0.01
	10-100	0.1	0.0001	10-100	0.1
	100-1000	1	0.001	100-1000	0.001
			1000-10000	10 *4	0.01
Unit (Viscosity)	mPa·s, Pa·s, cP, P			Pa·s, P	
Operating temperature	10 to 40°C (50 to 104°F)				
Minimum sample amount	2 mL or more		10 mL or more		
Temperature display	0 to 160°C/0.1°C, (32 to 320°F/0.1°F) *5				
Temperature measurement accuracy	0 to 20°C/32 to 68°F: ±1°C/±1.8°F				
	20 to 30°C/68 to 86°F: ±0.5°C/±0.9°F				
	30 to 100°C/86 to 212°F: ±2°C/±3.6°F				
	100 to 160°C/212 to 320°F: ±4°C/±7.2°F				
Display	Vacuum fluorescent display (VFD)				
Connection cable length	1.5 m (between the main unit and the display unit)				
Communication	RS-232C standard				
Power supply	AC adapter (Confirm that the adapter type is correct for the local voltage and power receptacle type.)				
Power consumption	Approx. 14 VA (Including the AC adapter)				
External dimensions/mass	Sensor unit: 112 (W) x 132 (D) x 291 (H) mm/Approx. 0.8 kg				
	Display unit: 238 (W) x 132 (D) x 170 (H) mm/Approx. 1.3 kg				
	Stand unit: 296 (W) x 314 (D) x 536 (H) mm/Approx. 4.6 kg				
Standard accessories (to be continued)	AC adapter (1 pc), Connection cable (1.5 m, 1 pc) Only for the SV-1A/10A/100A { <ul style="list-style-type: none"> <li>Sample cup (45 mL, 5 pcs)</li> <li>Disposable cup (10 mL, 5 pcs)</li> <li>Water jacket (1 pc)</li> <li>WinCT-Viscosity (1 pc)</li> <li>RS-232C cable (1 pc)</li> <li>Serial-USB converter (1 pc)</li> <li>Dust cover for the main unit (1 pc)</li> <li>Dust cover for the display unit (1 pc)</li> <li>X-Y-Z stage (1 pc)</li> <li>Stand for securing the sensor unit (1 pc)</li> <li>Positioning stopper (1 pc)</li> </ul>				

Standard accessories	Only for the SV-1A	Square glass sample cup (2 pcs) Sample cup (2 mL, 10 pcs) Glass sample cup (2 mL, 10 pcs) Sample cup holder (2 mL, Transparent: 3 pcs / Black: 2pcs) Sample cup stand (1 pc)
	Only for the SV-10A/100A	Small sample cup (10 mL, 5 pcs) Small sample cup cover (5 pcs) Glass sample cup (13 mL, 2 pcs) Glass sample cup holder (1 pc)
	Only for the SV-H series	Carrying case (1 pc)

Note: The values for the SV-H series are when using the AX-SV-51 (stand set, sold separately).

\*1 to \*5: See the next page for the detailed description.

\*1 For the SV-1A/1H when a sample cup of 2 mL is used. For the SV-10A/10H and SV-100A/100H when a sample cup of 45 mL is used.

\*2 Repetitive measurement with the sensor plates remaining in the sample

\*3 The value after calibration using a standard viscosity fluid at a temperature range between 20°C and 30°C with no condensation.  
In a measurement that takes a long time, perform calibration using a standard viscosity fluid or purified water periodically, as necessary.

\*4 The unit switches to Pa·s.

\*5 The operating temperature of each standard and optional accessory is as follow

Name	Temperature used
Sample cup-capacity 45 mL (AX-SV-33) Small sample cup-capacity 10 mL/Small sample cup cover (AX-SV-34) Sample cup-capacity 2 mL (AX-SV-58)* Sample cup holder-For capacity 2 mL (AX-SV-56-1/2)	0 to 120°C
Glass sample cup-capacity 13 mL (AX-SV-35) Glass sample cup-capacity 2 mL (AX-SV-59)	0 to 230°C
Water jacket (AX-SV-37)	0 to 100°C
Glass storage container (AX-SV-38)*	0 to 180°C
Plastic storage container (AX-SV-39)* Disposable cup-capacity 10 mL (AX-SV-63)	0 to 80°C

\* Lid: 80°C max

Take the operating temperature shown above into considerations when using the above items.

# 17. OPTIONAL ACCESSORIES

## List of Optional Accessories (sold separately)

Model	Name	Available (○)		
		1A/1H	10A/10H	100A/100H
AX-SV-31-2.5	Standard viscosity fluid (JS2.5)	○	○	
AX-SV-31-5	Standard viscosity fluid (JS5)	○	○	
AX-SV-31-10	Standard viscosity fluid (JS10)	○	○	
AX-SV-31-20	Standard viscosity fluid (JS20)	○	○	
AX-SV-31-50	Standard viscosity fluid (JS50)	○	○	
AX-SV-31-100	Standard viscosity fluid (JS100)	○	○	
AX-SV-31-200	Standard viscosity fluid (JS200)		○	
AX-SV-31-500	Standard viscosity fluid (JS500)		○	
AX-SV-31-1000	Standard viscosity fluid (JS1000)		○	
AX-SV-31-2000	Standard viscosity fluid (JS2000)			○*1
AX-SV-31-14000	Standard viscosity fluid (JS14000)			○
AX-SV-31-160000	Standard viscosity fluid (JS160000)			○
AX-SV-33	Sample cup (Capacity: 45 mL) 10 pcs	○	○	○
AX-SV-34	Small sample cup (Capacity: 10 mL) 10 pcs	○	○	○
AX-SV-35	Glass sample cup (Capacity: Approx.13 mL) 1 pc	○	○	○
AX-SV-36	Positioning stopper 1 pc	○	○	○
AX-SV-37	Water jacket 1 pc	○	○	○
AX-SV-38	Glass storage container (Capacity: Approx.50 mL) 10 pcs	○	○	○
AX-SV-39	Plastic storage container (Capacity: Approx.120 mL) 20 pcs	○	○	○
AX-SV-42	Analog output	○	○	○
AX-SV-43	Extension cable (5 m) To extend the distance between the main unit and the display unit.	○	○	○
AX-SV-51	Stand set (Used with all models of the SV series) ----- Stand for securing the sensor unit 1 pc X-Y-Z stage 1 pc Sample cup (Capacity: 2 mL, Lid attached) 1 pc Sample cup holder (For 2 mL capacity) 1 pc Sample cup (Capacity: 45 mL) 1 pc	○	○	○
AX-SV-52	X-Y-Z stage (Used with all models of the SV series) 1 pc	○	○	○
AX-SV-53-EX	Software set (Serial-USB converter included) (Used with all models of the SV series) ----- WinCT-Viscosity 1 pc RS-232C straight cable 1 pc Serial-USB converter 1 pc	○	○	○
AX-SV-54	Cup set (Capacity: 10 mL · 13 mL · 45 mL) (Water jacket included) (Used with all models of the SV series) ----- Sample cup (Capacity: 45 mL) 5 pcs Small sample cup (Capacity: 10 mL) 5 pcs Small sample cup cover 5 pcs Glass sample cup (Capacity: Approx.13 mL) 2 pcs Glass sample cup holder 1 pc Water jacket 1 pc	○	○	○

\*1 When calibrating with the SV-100A/100H, use the viscosity fluid at 25°C or below.

Model	Name	Available (○)		
		1A/1H	10A/10H	100A/100H
AX-SV-55	Cup set (Capacity: 2 mL) (Water jacket included) (Used with all models of the SV series) Sample cup (Capacity: 45 mL) 5 pcs Sample cup (Capacity: 2 mL, Lid attached) 10 pcs Glass sample cup (Capacity: 2 mL) 2 pcs Sample cup holder (For 2 mL capacity) 5 pcs Sample cup stand (For 2 mL capacity) 1 pc Water jacket 1 pc	○		
AX-SV-56-1	Sample cup holder (Transparent) 5 pcs	○		
AX-SV-56-2	Sample cup holder (Black) 5 pcs	○		
AX-SV-57	Sample cup stand (For 2 mL capacity) 2 pcs	○		
AX-SV-58	Sample cup (Capacity: 2mL, Lid attached) 100 pcs	○		
AX-SV-59	Glass sample cup (Capacity 2 mL) 5 pcs Sample cup stand (For 2 mL capacity) 1 pc	○		
AX-SV-62-1	Dust cover for the main unit	○	○	○
AX-SV-62-2	Dust cover for the display unit	○	○	○
AX-SV-63	Disposable cup (PET, Capacity 10 mL) 40 pcs	○	○	○
AX-USB-25P	Serial-USB converter	○	○	○
AD-1671A	Anti-vibration table	○	○	○
AD-1682	Rechargeable battery	○	○	○
AD-1687	Weighing environment logger	○	○	○
AD-1688	Weighing data logger	○	○	○
AD-8121B	Compact printer	○	○	○
AD-8527	Quick USB adapter	○	○	○

### AX-SV-33 Sample Cup

- The AX-SV-33 consists of :  
Sample cup (Capacity: 45 mL) 10 pcs  
(Polycarbonate, Operating temperature: 120°C max.)

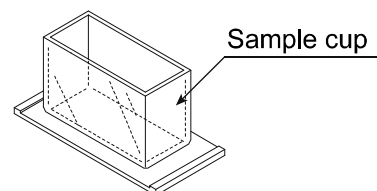

### AX-SV-34 Small Sample Cup (10mL)

- Used to measure a small amount of sample.
- The AX-SV-34 consists of :  
Small sample cup (10 mL) 10 pcs  
Small sample cup cover 10 pcs  
Sample cup 1 pc  
(All: Polycarbonate, Operating temperature: 120°C max.)

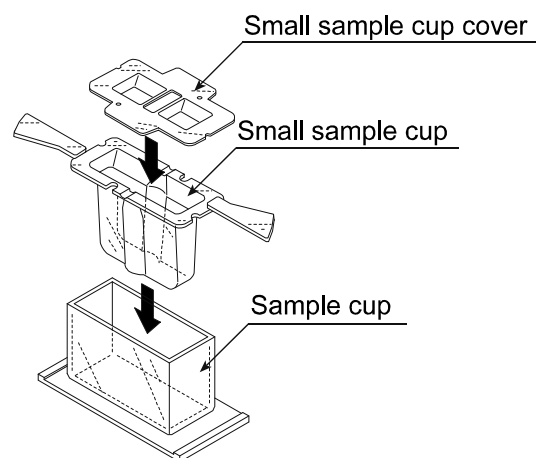

## AX-SV-35 Glass Sample Cup (Approx. 13 mL)

- Used to measure organic solvents.
- The AX-SV-35 consists of :
 

Glass sample cup (Capacity: Approx.13 mL)	1 pc
(Pyrex® glass, Operating temperature: 230°C max.)	
Glass sample cup holder (Stainless steel)	1 pc
Sample cup	1 pc
(Polycarbonate, Operating temperature: 120°C max.)	

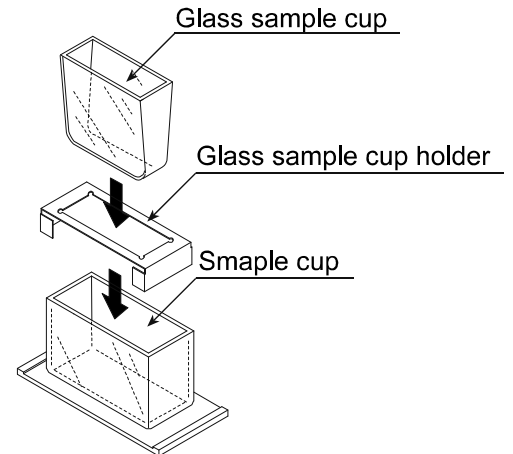

## AX-SV-36 Positioning Stopper

- Used to secure the position of the sensor unit and the sensor plates so that positioning the sensor plates and the sample surface is not required each time a measurement is performed in a repetitive test. See below for how to attach the positioning stopper.

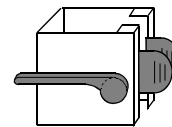

### How to attach the positioning stopper:

- 1 Raise the lever so that the sensor unit can be moved.
- 2 While pinching the grips, lift out the sensor unit from above.
- 3 While pinching the grips on the positioning stopper, attach the stopper, with the lever on the left side as seen from front, on the supporting post. Be sure to place the guides located on the inner wall of the stopper in the guide channels located on the supporting post.
- 4 Position the stopper at an appropriate height. Raise the lever to secure the stopper.
- 5 While pinching the grips, attach the sensor unit on the supporting post.
- 6 Lower the sensor unit until it comes into contact with the stopper.
- 7 Lower the lever to secure the sensor unit.

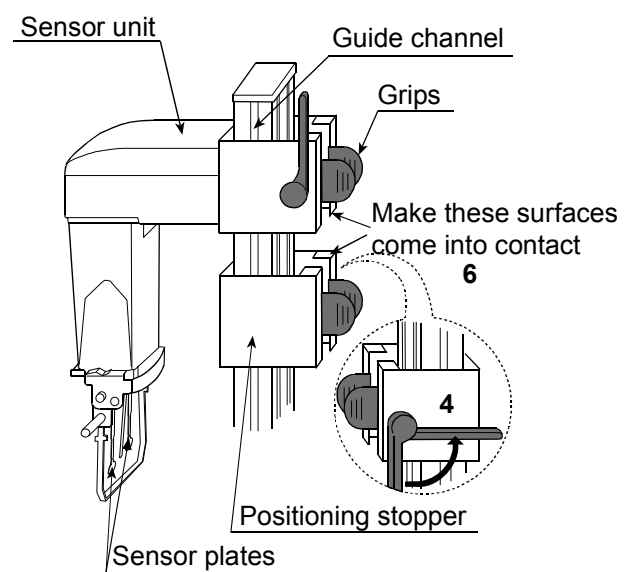
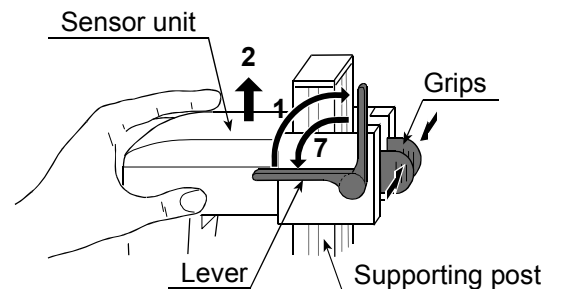

## AX-SV-37 Water Jacket Assembly

- Used, in combination with a commercially available constant temperature bath for heating medium circulation, to maintain the sample temperature constant or to measure the viscosity while changing the sample temperature.
- The glass sample cup sold separately can also be used.
- The AX-SV-37 consists of :

Water jacket (Main body: Polycarbonate, Packing: Silicone rubber, Washer: Nylon)	1 pc
Small sample cup (Polycarbonate, Operating temperature: 120°C max.)	4 pcs
Small sample cup cover (Polycarbonate, Operating temperature: 120°C max.)	4 pcs
Screw (Screw: Polyacetal, Washer: Nylon)	1 pc

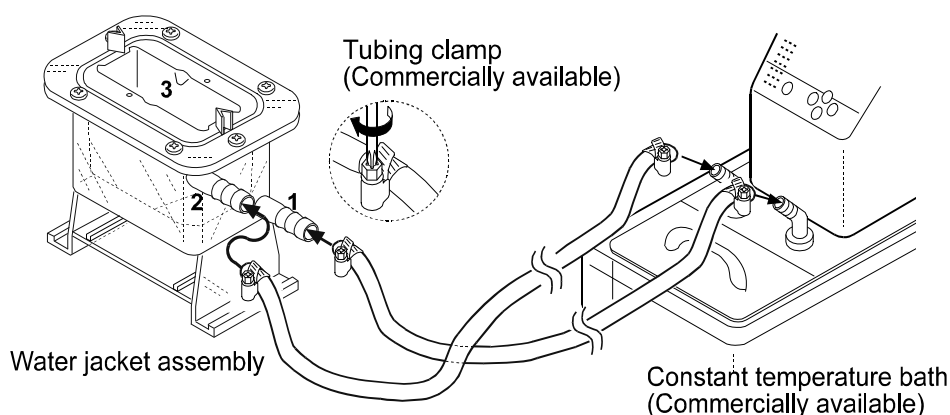
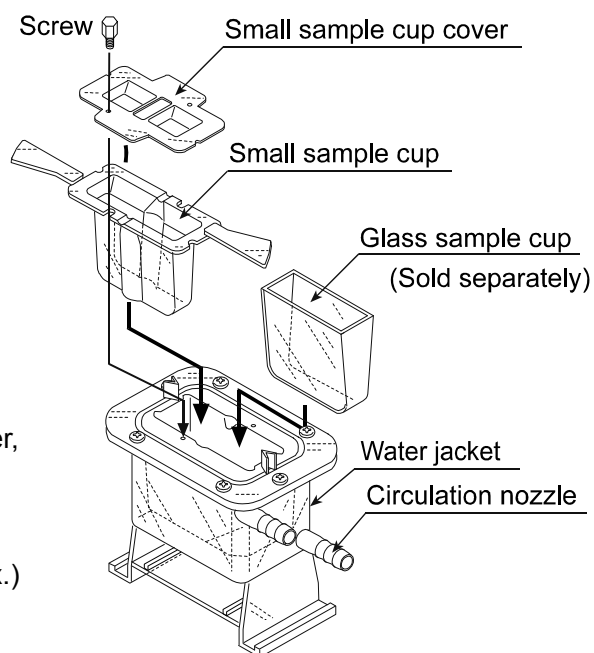

- Specifications Circulation nozzle: Outside diameter 10.5 mm  
Recommended hose: Silicone tube, inside diameter 8 mm
- It is recommended that, for safety, a commercially available tubing clamp (clamping size: 11 to 20 mm) be used to fasten the tube securely to the nozzle.
- When using the water jacket, make sure that no inner pressure is exerted in the water jacket due to the kinked or blocked tubes, as that could exert the pressure in the water jacket, causing it to break.
- When a stirrer is attached at the bottom of the water jacket, the sample viscosity can be measured while the sample is being stirred. The maximum viscosity value which can be measured is 1000 mPa·s.

Stirrer: Cimarec TM i Micro Stirrers manufactured by Thermo Fisher Scientific  
Use a rotator with a size of 6 mm (length) x 4 mm (diameter).

### AX-SV-38 Glass Storage Container

- Used to store sample fluids.

The viscosity of the sample stored in the container can be measured as it is.

- The AX-SV-38 consists of :

Glass storage container (Capacity: Approx.50 mL) 10 pcs  
(Borosilicate glass, Operating temperature: 180°C max.)

Lid 10 pcs  
(Polyethylene, Operating temperature: 80°C max.)

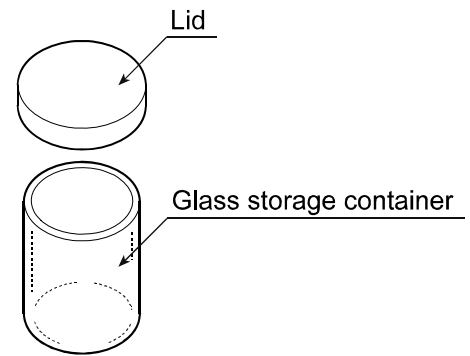

### AX-SV-39 Plastic Storage Container

- Used to store sample fluids.

The viscosity of the sample stored in the container can be measured as it is.

- The AX-SV-39 consists of :

Plastic storage container (Capacity: Approx.120 mL) 20 pcs  
(Polypropylene, Operating temperature: 80°C max.)

Lid 20 pcs  
(Polyethylene, Operating temperature: 80°C max.)

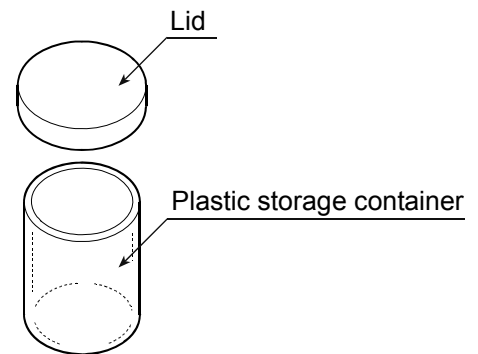

### AX-SV-51 Stand Set

- Used to secure the sensor unit while measuring the viscosity of a sample.

- Consists of :

Stand for securing the sensor unit 1 pc  
X-Y-Z stage 1 pc

- Used when a small amount of sample (2 mL) will be measured. (Only for the SV-1A/SV-1H)

- Consists of :

Sample cup (Capacity: 2 mL) 1 pc  
Sample cup holder 1 pc  
Sample cup (Capacity: 45 mL) 1 pc  
(Polycarbonate, Operating temperature: 120°C max.)  
Lid 1 pc  
(Polypropylene, Operating temperature: 80°C max.)

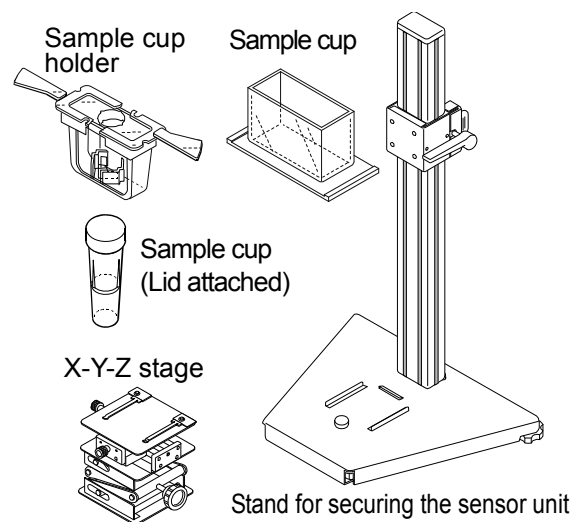

### AX-SV-52 X-Y-Z Stage

- Used to support and adjust the sample cup position.

- Consists of :

X-Y-Z stage 1 pc

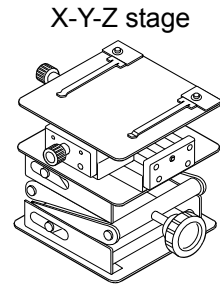

### AX-SV-53-EX Software Set

- Used while acquiring the viscosity data with a personal computer.

- Consists of :

WinCT-Viscosity 1 pc

RS-232C straight cable 1 pc

Serial-USB converter 1 pc

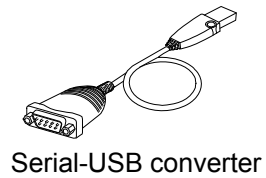
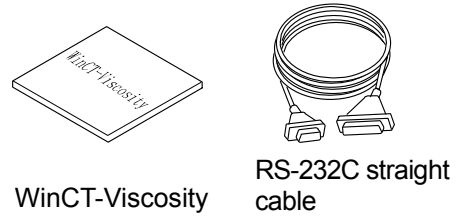



## AX-SV-54 Cup Set (10 mL / 13 mL / 45 mL)

(Use the AX-SV-51 Stand Set if necessary.)

- Used to measure a small amount of sample (10 mL).

- Consists of :

Sample cup (45 mL)                      5 pcs

Small sample cup (10 mL)            5 pcs

Small sample cup cover                5 pcs

(All: Polycarbonate, Operating temperature: 120°C max.)

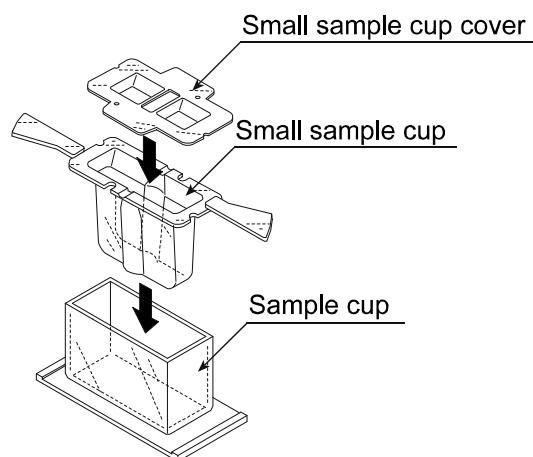

Used to measure organic solvents.

Glass sample cup (Capacity: Approx. 13 mL)    2 pcs

(Pyrex® glass, Operating temperature: 230°C max.)

Glass sample cup holder (Stainless steel)    1 pc

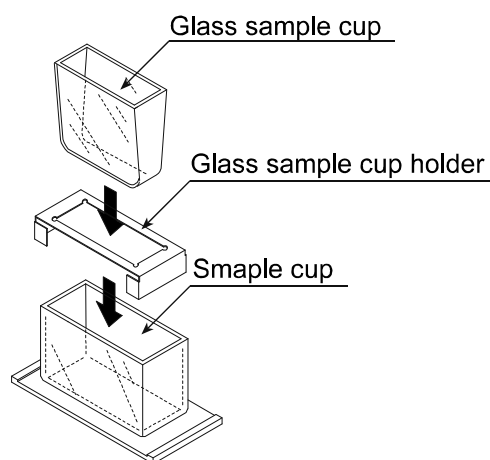

- Water Jacket

Used, in combination with a commercially available constant temperature bath for heating medium circulation, to maintain the sample temperature constant or to measure the viscosity while changing the sample temperature.

- Consists of :

Water jacket                                      1 pc

(Main body: Polycarbonate, Packing: Silicone rubber,  
Washer: Nylon)

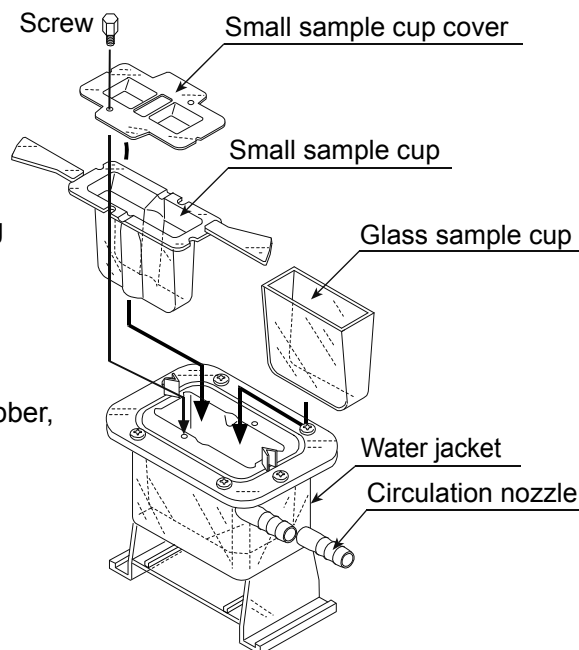

**Only for the SV-1A/SV-1H (When using this option, use the AX-SV-51 Stand Set)**

**AX-SV-55 Cup Set (2 mL)**

- Sample cup set (Only for the SV-1A/SV-1H)

Used to measure a small amount of sample (2 mL).

- Consists of :

Sample cup (45 mL)	5 pcs
Sample cup (2 mL)	10 pcs
Small cup holder	5 pcs
(All: Polycarbonate, Operating temperature: 120°C max.)	
Lid	1 pc
(Polypropylene, Operating temperature: 80°C max.)	

Used to measure a small amount of organic solvents.

Glass sample cup (Capacity: 2 mL) 10 pc  
(Pyrex® glass, Operating temperature: 230°C max.)

Sample cup stand 1 pc

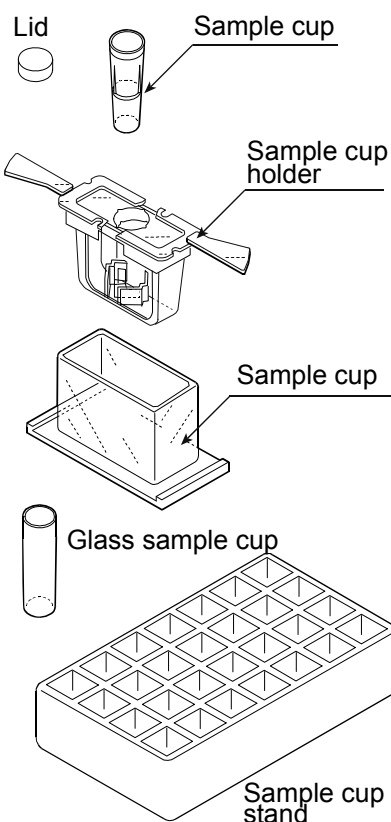

- Water Jacket

Used, in combination with a commercially available constant temperature bath for heating medium circulation, to maintain the sample temperature constant or to measure the viscosity while changing the sample temperature.

- Consists of :

Water jacket	1 pc
(Main body: Polycarbonate, Packing: Silicone rubber, Washer: Nylon)	

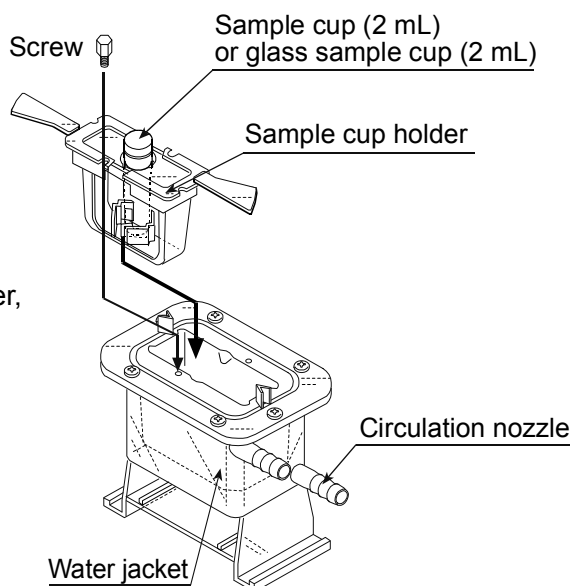

### **AX-SV-56-1 Sample Cup Holder (For 2 mL capacity, Transparent)**

### **AX-SV-56-2 Sample Cup Holder (For 2 mL capacity, Black)**

- Used to support a 2mL sample cup during measurement.  
(Only for the SV-1A/SV-1H)

- Consists of :

Sample cup holder                      5 pcs

Sample cup (45 mL)                    5 pcs

(All: Polycarbonate, Operating temperature: 120°C max.)

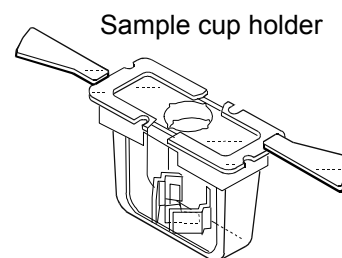

### **AX-SV-57 Sample Cup Stand (For 2 mL capacity)**

- Used to support 2mL sample cups.  
(Only for the SV-1A/SV-1H)

- Consists of :

Sample cup stand                      2 pcs

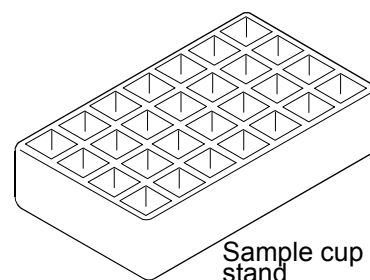

### **AX-SV-58 Sample Cup (2 mL)**

- Sample cup set (Only for the SV-1A/SV-1H)

Used to measure a small amount of sample (2 mL).

- Consists of :

Sample cup (2 mL)                      100 pcs

(Polycarbonate, Operating temperature: 120°C max.)

Lid    100 pcs

(Polypropylene, Operating temperature: 80°C max.)

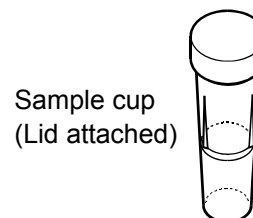

### **AX-SV-59 Glass Sample Cup (2 mL)**

- Glass sample cup and Sample cup stand set (Only for the SV-1A/SV-1H)

Used to measure a small amount of organic solvents (2 mL).

Used to support 2 mL sample cups.

- Consists of :

Glass sample cup (Capacity: 2 mL)    5 pcs

(Pyrex® glass, Operating temperature: 230°C max.)

Sample cup stand                      1 pc

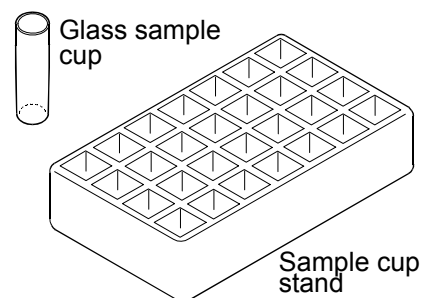

### AX-SV-60 Square Glass Sample Cup (10 mm x 10 mm x 45 mm)

- Can be used for optical measuring devices such as a spectrophotometer.

- Consists of :

Square glass sample cup (Pyrex® glass)	2 pcs
Square lid (Polypropylene)	2 pcs

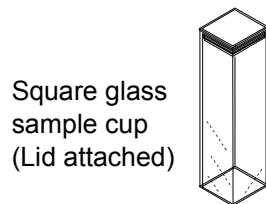

### AX-SV-62-1 Dust Cover for the Main Unit

- Used to protect the viscometer main unit from dust and dirt.

- Consists of :

Dust cover for the main unit	1 pc
------------------------------	------

Dust cover for the main unit

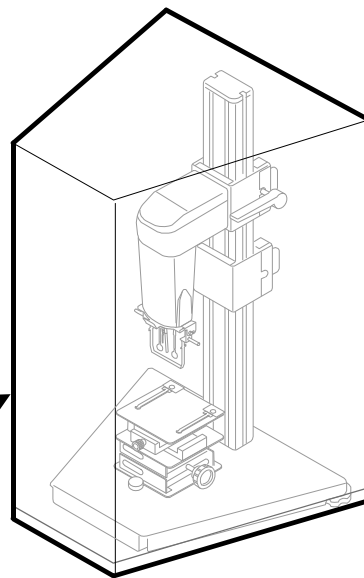

### AX-SV-62-2 Dust Cover for the Display Unit

- Used to protect the viscometer display unit from dust and dirt.

- Consists of :

Dust cover for the display unit	1 pc
---------------------------------	------

Dust cover for the display unit

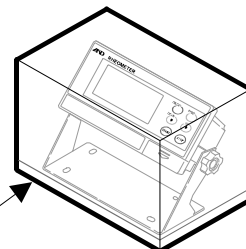

### AX-SV-63 Disposable Cup (PET)

- Used in place of the small sample cup or the glass sample cup and can be disposed of after use.

- Consists of :

Disposable cup (10 mL)	40 pcs (Two bags of 20 cups each)
------------------------	-----------------------------------

(Polyethylene terephthalate (PET), Operating temperature: 80°C max.)

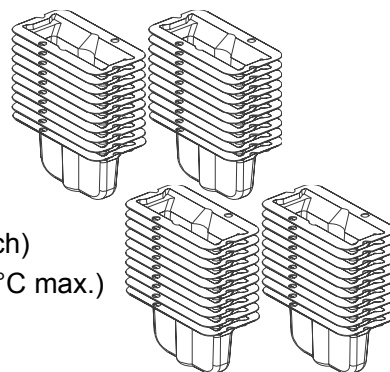

# 18. EXTERNAL DIMENSIONS

## SV-1H / SV-10H / SV-100H Sensor unit (Handle\*)

\* The SV-A series external dimensions are as follows when the handle is used.

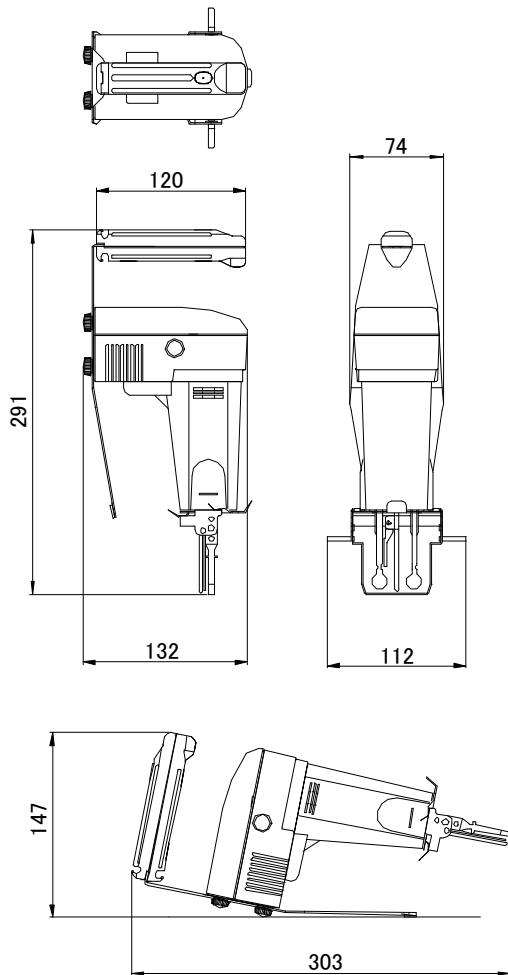

## Display unit (For all models)

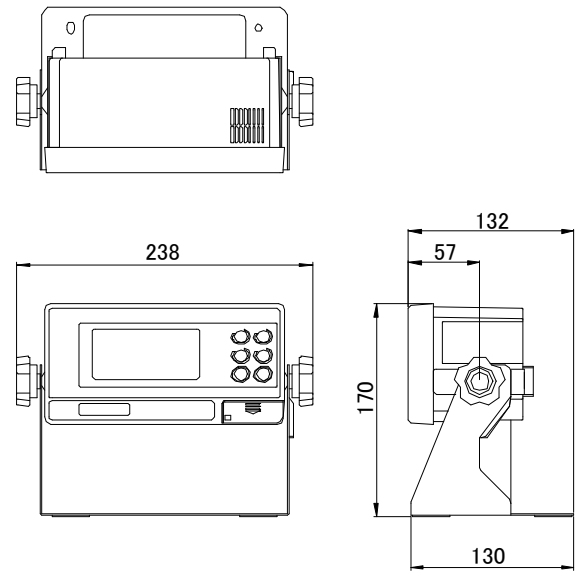

The connection cable is 1.5m long.

Unit: mm

## SV-1A / SV-10A / SV-100A Stand unit\*

\* The SV-H series external dimensions are as follows when the AX-SV-51 (stand set) is used.

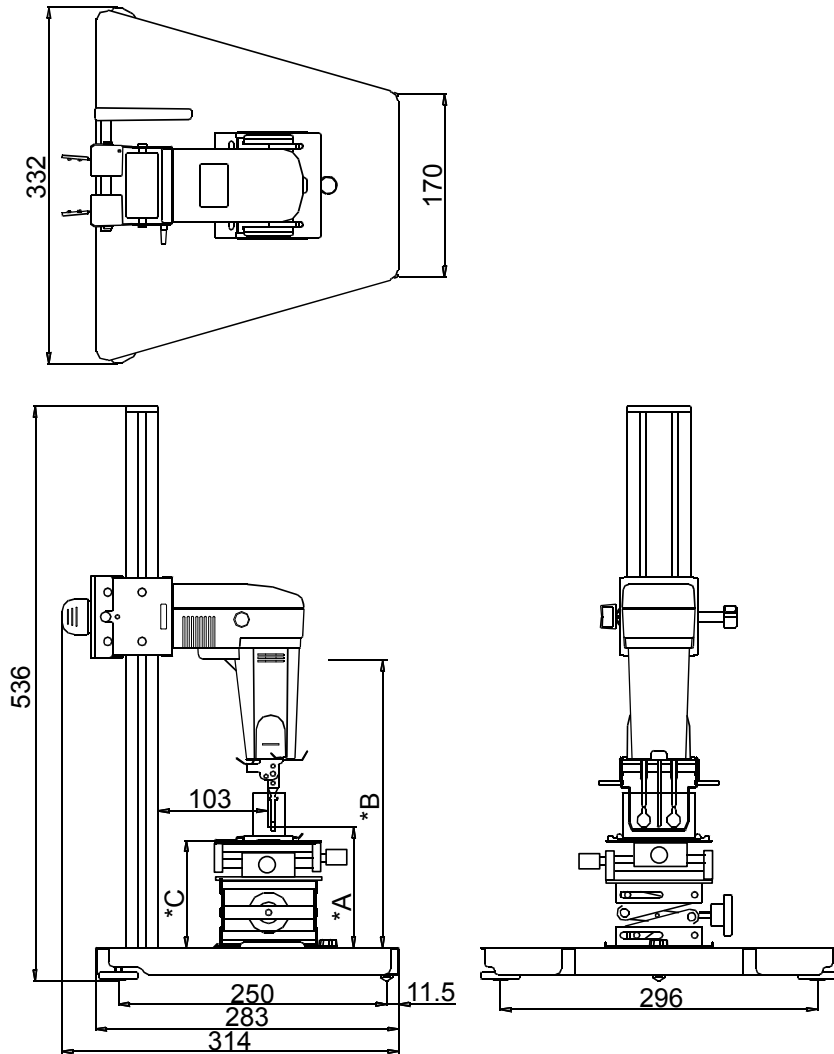

\*A=Sensor plates lowest position 3.5 mm (With protector used, no table)

\*B=Sensor plates highest position 268 mm

\*C=Table height 54 to 140 mm

**Unit: mm**

## Detailed View of the Sensor Unit

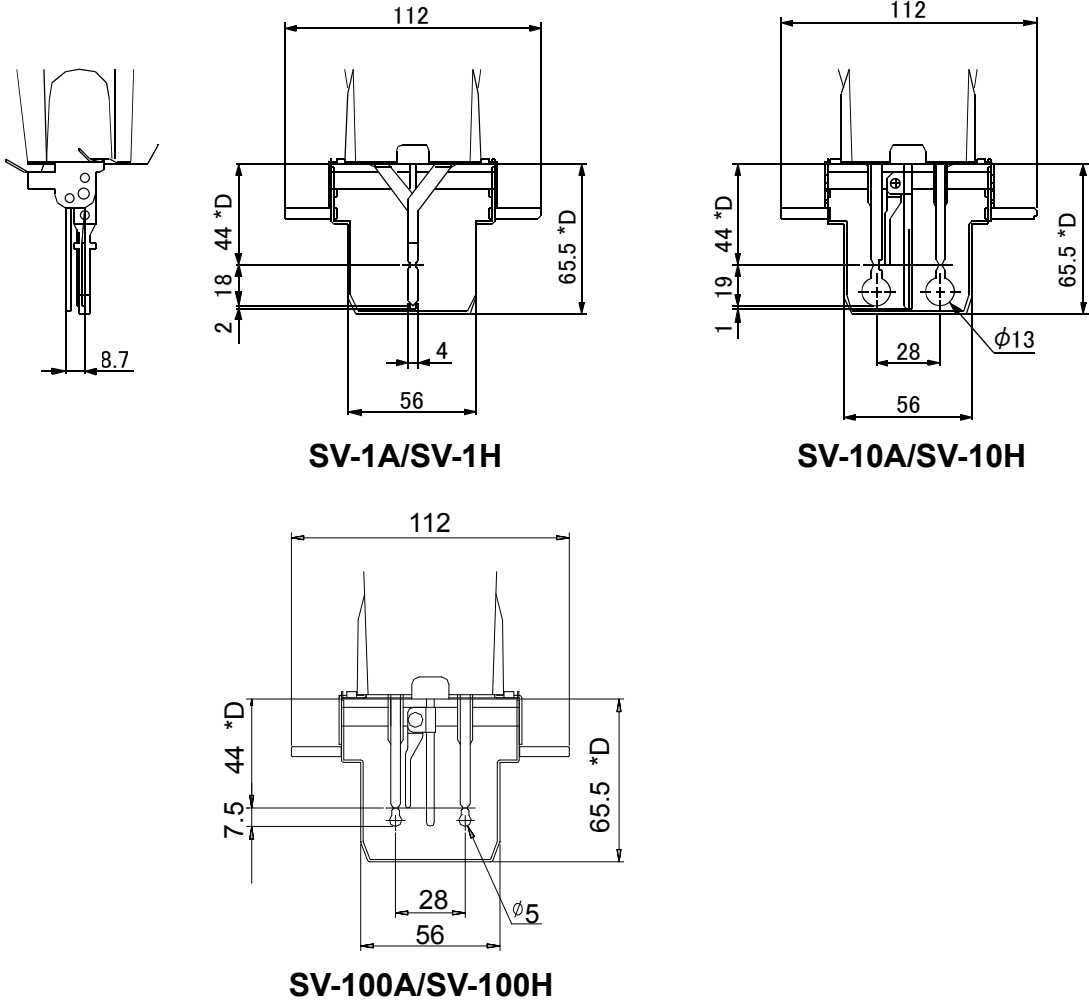

\*D=Distance from the sensor protective cover

Unit: mm













### **A&D Company, Limited**

3-23-14 Higashi-Ikebukuro, Toshima-ku, Tokyo 170-0013, JAPAN  
Telephone: [81] (3) 5391-6132 Fax: [81] (3) 5391-6148

### **A&D ENGINEERING, INC.**

1756 Automation Parkway, San Jose, California 95131, U.S.A.  
Telephone: [1] (408) 263-5333 Fax: [1] (408)263-0119

### **A&D INSTRUMENTS LIMITED**

Unit 24/26 Blacklands Way, Abingdon Business Park, Abingdon, Oxfordshire OX14 1DY United Kingdom  
Telephone: [44] (1235) 550420 Fax: [44] (1235) 550485

### **A&D AUSTRALASIA PTY LTD**

32 Dew Street, Thebarton, South Australia 5031, AUSTRALIA  
Telephone: [61] (8) 8301-8100 Fax: [61] (8) 8352-7409

### **A&D KOREA Limited**

한국에이.엔.디(주)  
서울특별시 영등포구 국제금융로6길33 (여의도동) 맨하탄빌딩 817 우편 번호 150-749  
( 817, Manhattan Bldg., 33. Gukjegeumyung-ro 6-gil, Yeongdeungpo-gu, Seoul, 150-749 Korea )  
전화: [82] (2) 780-4101 팩스: [82] (2) 782-4280

### **ООО A&D RUS**

ООО "ЭЙ энд ДИ РУС"  
121357, Российская Федерация, г.Москва, ул. Вереysкая, дом 17  
( Business-Center "Vereyskaya Plaza-2" 121357, Russian Federation, Moscow, Vereyskaya Street 17 )  
тел.: [7] (495) 937-33-44 факс: [7] (495) 937-55-66

### **A&D INSTRUMENTS INDIA PRIVATE LIMITED**

509, उद्योग विहार , फेस -5, गुडगांव - 122016, हरियाणा , भारत  
( 509, Udyog Vihar, Phase-V, Gurgaon - 122 016, Haryana, India )  
फोन : 91-124-4715555 फैक्स : 91-124-4715599

ऐ&डी इन्स्ट्रुमेन्ट्स इण्डिया प्रा० लिमिटेड