

HW-D

WEIGHING INDICATOR

INSTRUCTION MANUAL

Weighing Indicator

MODEL HW-D

AND
A&D MERCURY PTY. LTD.

HW-D-SU-OZ-4/98

Table of contents

Introduction	2
Unpacking	2
Capacity & Minimum Division	2
Specifications	3
Load Cell Connection	3
Connection Diagram	4
Function Parameter Settings	5
Correction for Acceleration due to gravity	9
Calibration	11
Calibration Weight Table	14
Power Sources	15
Panel Parts Names & Functions	16
Front Panel	16
Rear Panel	18
Method of Use	19
Starting	19
Weight Display Mode	19
Counting Mode	20
Recording Unit Weight	20
Comparator	21
Comparator Function	21
Setting the Upper & Lower Limits	22
Percentage Mode	23
Percentage Display	23
Recording the 100% Weight	23
Changing the Batteries	23
Options & Accessories	24
OP-03 Data Output	25
Comparator Section	27
AX-WM-B31727 Wall mounting fixture	29
Appendix - Gravity Values	30

INTRODUCTION

The HW-D digital indicator is used in the construction of high performance scales. It has the same specifications as the indicator used in the HW Series industrial platform scales. There are a few limitations to be observed to obtain the full performance of the HW-D indicator :-

1. Up to a maximum of 4 x 350 Ω load cells may be used.
2. The load cell cable should not exceed 5 metres in length as there is no remote sensing capability.
3. The capacities and resolutions are fixed and must be selected from the pre-programmed list.

The indicator is a quality component for use with the majority of platform designs and the options available for the HW series may be used to extend it's capability.

UNPACKING

Enclosed in each HW-D shipping carton you should find the following items:-

1. The digital indicator
2. The 5 pin load cell connector
3. The AC mains adaptor TB-108
5. 6 x 'C' size batteries
4. This Instruction Manual

CAPACITY & MINIMUM DIVISION

Select your required capacity from the table and use the procedure on page 5 to make this the active setting. The minimum division is pre-set by the software corresponding to your selected capacity.

Capacity	Resolution	No. Divisions	Function F4 setting
30.00	.01	3000	0
60.00	.01	6000	1
150.00	.02	7500	2
15.000	.002	7500	3
100.00	.01	10000	4
10.000	.001	10000	5
300.00	.05	6000	6
600.0	.1	6000	7
1200.0	.2	6000	8
31.00	.01	3100	9
60.00	.02	3000	A
150.00	.05	3000	b
30.000	.005	3000	7
300.0	.1	3000	d
600.0	.2	3000	e
1200	.5	2400	F

SPECIFICATIONS

1. Load Cell Excitation	5V±10%
2. Load Cell Capability	4 x 350Ω Load Cells
3. Input Signal Range	
Zero Input Voltage	0.5mV
Full Input Voltage	12.5mV
Input Sensitivity	0.4μV/D (1.0μV/D NSC Approved)
4. Temperature Coefficient (-10°C~40°C)	
Zero	±(0.3μV+0.0008% of reading)/°C
Span	±0.0008%/°C of reading
5. Non-Linearity	0.01% of F.S.
6. Input Impedance	>10MΩ
7. A/D Conversion Method	Dual Slope Integration
8. A/D Conversion Rate	Approx. 5 times per second
9. Power Requirements	DC 9V (6 x 'C' batteries provided) or AC Adaptor (TB-108 provided)
10. Operating Temperature	-10°C~40°C

LOAD CELL CONNECTION

Use a 4 wire cable with an overall shield to connect the load cell to the indicator.

The analogue signal from the load cell and the RS232C signals are sensitive to electrical noise. If using the RS232C option, do not bind these cables together as it could result in cross-talk interference. Also keep both of these cables away from AC power cables.

LOAD CELL CABLE CONNECTION CHART

Pin No.	Signal
1	Positive Excitation Voltage (EXC+)
2	Positive Signal Voltage (SIG+)
3	Negative Signal Voltage (SIG-)
4	Negative Excitation Voltage (EXC-)
5	Shield (SHLD)

SPECIFICATIONS

CONNECTION DIAGRAM

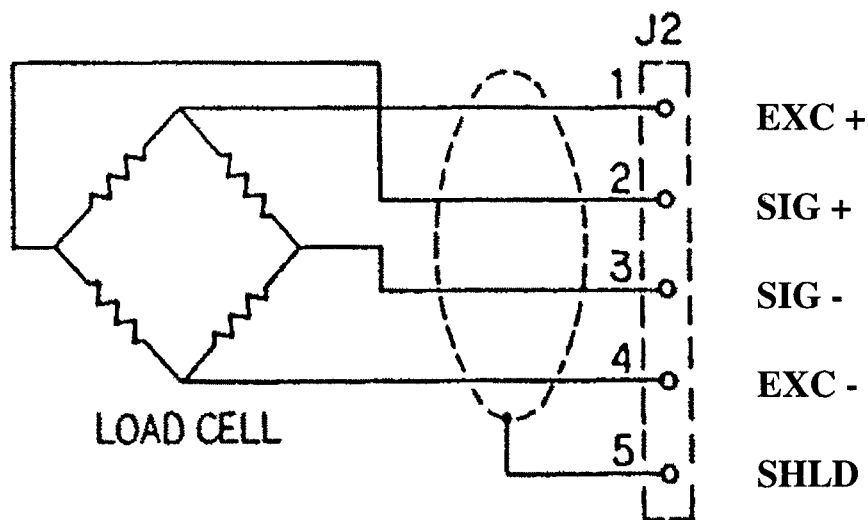

Connect the 5 pin connector to the load cell cable from the basework taking care to crimp the contacts securely.

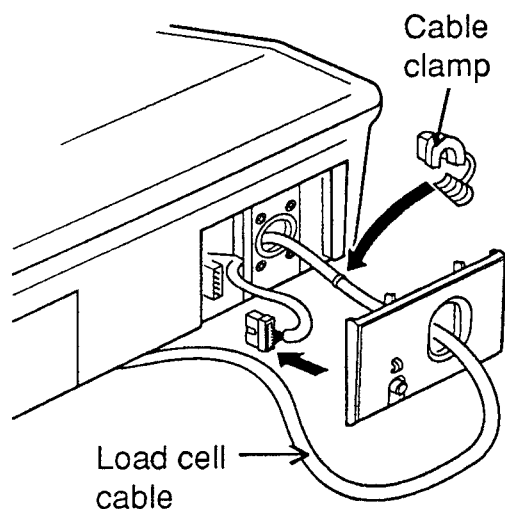

Make the electrical connection to the indicator:-

- Remove the calibration switch cover.
- Feed the cable connector through the calibration cover hole, through and around the internal plate and carefully mate the connectors.
- Fit the cable clamp and the calibration switch cover to complete the installation.

FUNCTION PARAMETER SETTINGS

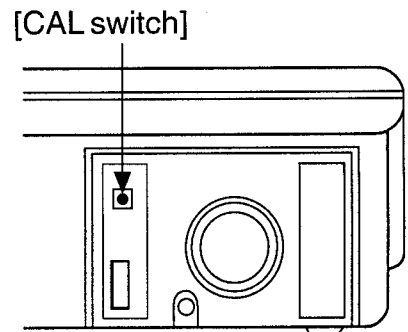
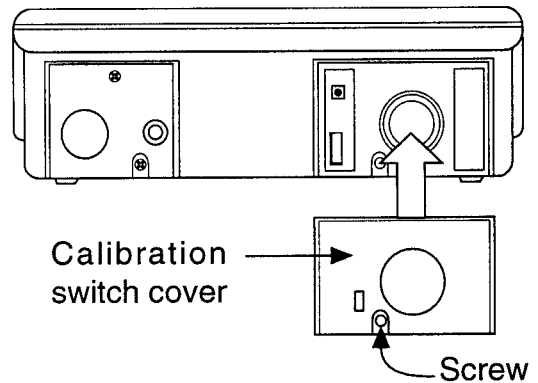
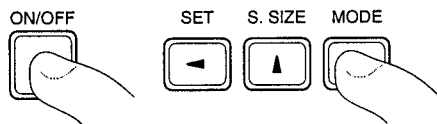

This section concerns disabling and enabling functions of the HW-D digital indicator.

- Step 1. With the scale off, remove the calibration switch cover.
- Step 2. Press and hold the **[CAL]** (on the rear), and **[MODE]** keys.
- Step 3. Then, press **[ON/OFF]** key. Release all keys.



Note: The use of each key as you move through this procedure is listed below. Please take a moment to read each.

You are now able to just view (by only pressing the **[MODE]** key), or change the parameter settings (using the **[ZERO]** key to enter).

 ZERO	<ul style="list-style-type: none"> The [ZERO] key enters the settings into memory. "F0" and "F1" are entered individually, "F2" through "F4" are entered as a group. ("F5 and "F6" are entered after "F2" through "F4") At the end of the "F" cycle, "END" will be displayed.
 MODE	<ul style="list-style-type: none"> Use the [MODE] key to view the settings, and to escape a setting if you have made a mistake. You can not enter the settings with the [MODE] key, it will only move you through the settings with no change.
 S. SIZE	<ul style="list-style-type: none"> Once in the "F" group, use this key to move incrementally through the settings available for each group, ie:

F2 0
▶
F2 1
▶
F2 2

At this time the display will show "F0 0" (or "F0 1").

F0 0	F0 is the automatic function: Power off after three minutes
F0 0	Function Disabled
F0 1	Function Enabled

Step 4. Use the **S.SIZE** key to move incrementally between "F0 0" to "F0 1". When the desired setting is displayed, press **ZERO** to enter the setting into memory, and move to F1.

F1 0	F1 is the function: Counting Mode Enable / Disable
F1 0	Function Enabled
F1 1	Function Disabled

Step 5. After using the **S.SIZE** key to move to the desired setting. Press **ZERO** to enter the setting into memory, and move to F2.

F2 0	F2 is the function: Zero Band
F2 0	10% of Maximum Capacity
F2 1	5% fo Maximum Capacity
F2 2	2% fo Maximum Capacity

Note: "F2 0" through "F4 2" are entered in as a block, in other words you will need to make any changes in "F2" through "F4" and then when you press **ZERO**, they will all be entered.

If there is no change in an "F" group, then press **MODE** to move you without change.

Step 6. After using the **[S.SIZE]** key to move to the desired setting. Press **[MODE]** to move to F3.

F3 0		F3 permits the use of "lb" and sets the TARE and ZERO conditions
* NSC setting	F3 0	TARE works when the display is stable, but will not work if "ZERO" is displayed. "lb/oz" is not displayed (OIML/Most Countries).
	F3 1	TARE always works when the display is stable, "lb/oz" is displayed (USA)
	F3 2	TARE is permitted when the scale is stable, and the display is not at the center-of-zero. "lb/oz" is not displayed (New Zealand).
	* F3 3	TARE is permitted when the scale is stable, and the display is not zero. After TARE , the ZERO and NET indicators will switch on simultaneously. While TARE is entered, ZERO does not work. "lb/oz" is not displayed (Australia).

Step 7. Alter using The **[S.SIZE]** key to move to the desired setting, press **[MODE]** to move to "F4 "

F4 0		F4 sets the maximum capacity	
* NSC setting	* F4 0	30.00 x .01	F4 8 1200.0 x .2
	F4 1	60.00 x .01	F4 9 31.00 x .01
	F4 2	150.00 x .02	* F4 A 60.00 x .02
	F4 3	15.000 x .002	* F4 b 150.00 x .05
	F4 4	100.00 x .01	F4 C 30.000 x .005
	F4 5	10.000 x .001	* F4 d 300.0 x .1
	F4 6	300.00 x .05	* F4 E 600.0 x .2
	F4 7	600.00 x .1	* F4 F 1200 x .5

NOTE: You can go back to beginning of the cycle by pressing the **[MODE]** key instead of the **[ZERO]** key, but no settings will be entered into memory until **[ZERO]** is pressed.

F5 and F6 apply only to the HW series scales.

Step 9. After using the **[S.SIZE]** key to move to the desired setting, press **[ZERO]** to enter the settings ("F2 0" through "F4 2") into memory and move to F5.

F5 0	F5 sets the communication mode of the RS-232 interface
F5 0	STREAM mode
F5 1	COMMAND mode, terminator is <CR>+<LF>
F5 2	COMMAND mode, terminator is <CR>

Step 10. After using the **[S.SIZE]** key to move to the desired setting, press **[ZERO]** to enter the settings and move to F6.

F6 0	F6 sets the comparator mode environment.	
Setting	Comparator function is ON or OFF when the scale is powered on	Comparator Buzzer and Relay Output
F6 0	OFF	Always
F6 1	OFF	Prohibited near zero
F6 2	ON	Always
F6 3	ON	Prohibited near zero

Display Display will show "END".

Note: You may also go back to the beginning of the cycle "F0" by pressing **[MODE]**, and not **[ZERO]**, but no settings will be entered into memory until **[ZERO]** is pressed.

End End of Software Parameter Settings procedure.

Correction for Acceleration Due to Gravity

In the HW-D digital indicator, in order to obtain the correct weight, a correction function for the acceleration due to gravity is provided. To perform accurate weighing, it is necessary to set the acceleration due to gravity to match that of the area where the scale is being used. (Refer to the Appendix page 30: Values of acceleration due to gravity.)

Display check

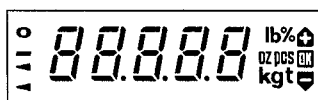

Bar display

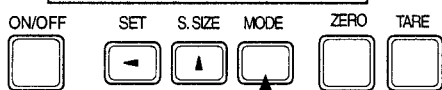
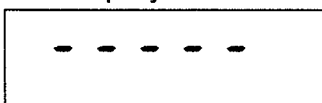

Press

- (1) Switch the power ON.
After the display check, if the bar display is shown, press the **MODE** switch to display the weighing result, etc. (including E and -E displays).

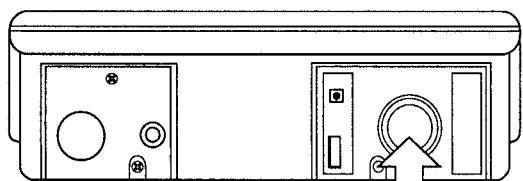

- (2) Remove the calibration switch cover.

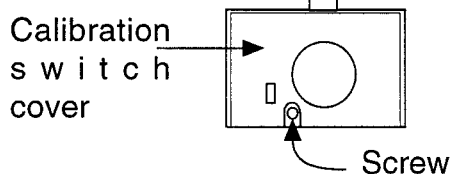

[CAL switch]

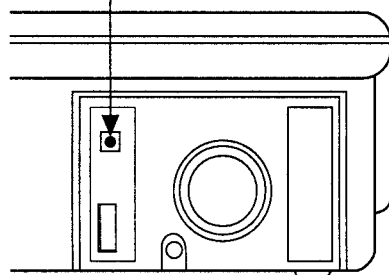

- (3) Press the **CAL** switch.
By pressing the **CAL** switch, the calibration mode is entered and a four-figure numerical value **9. ***** is displayed.

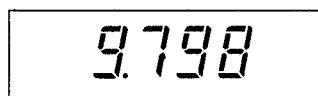

- (4) Acceleration due to gravity
The four-figure number displayed when the calibration mode is entered, is the currently set gravity acceleration value.

If the gravity value matches the area it is being calibrated in, press **MODE** and move to the calibration procedure.

If the calibration has been completed and the scale is to be used in another area, reset the gravity value to that of the area where the scale is to be used.

Example: For setting the gravity acceleration from 9.798 (the factory setting) to 9.806 (the value for Milan or Ottawa).



Functions of the keys used:

S.SIZE Adds 1 to the value of the digit that is flashing. After pressing this key, the value stops flashing.

SET The digit to be changed moves one figure to the left and flashes.

ZERO Stores the data in memory.

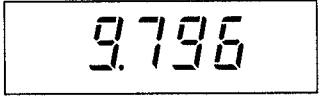
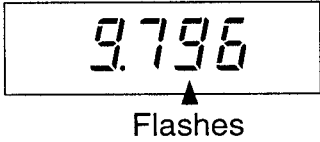
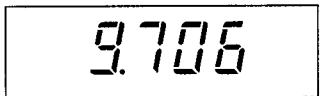
MODE Data is not changed and the mode progresses to the zero adjustment mode.

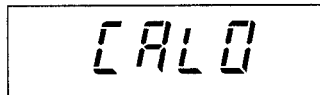
- (1)  Press the **SET** switch to select the first figure. (The first figure flashes.)
- (2)  Press the **S.SIZE** switch to change the number of the first figure to "6".
- (3)  Press the **SET** switch to select the second figure. (The second figure flashes.)
- (4)  Press the **S.SIZE** switch to change the number of the second figure to "0".
- (5)  Press the **SET** switch once to select the third figure. (The third figure flashes.)
- (6)  Press the **S.SIZE** switch to change the number of the third figure to "8".
- (7)  Using the above procedure, the gravity acceleration setting has been completed. Press the **ZERO** switch to store the data in memory.

If the scale requires calibration, continue with the calibration procedure step 3.

If the calibration has been completed and the gravity value is being set to that of another area, press the **CAL** key to exit the setting procedure.

CALIBRATION

Attention

In territories where scales using the HW -D digital indicator are registered for commercial use, the end-user should not be given this information, as he will not be permitted to break the seals to carry out span calibration for himself. In this case, calibration would be carried out by the responsible authorities, and the calibration settings would then be sealed.

Calibration Introduction

Calibration of the scale is required when it is initially installed, if the scale is moved a substantial distance, or in accordance with local regulations. This is necessary because the weight of a mass in one location is not necessarily the same in another location. Also, with time and use, mechanical deviations can occur.

"Weight" equals mass times acceleration due to Earth's field of gravity. The internationally adopted value for gravitational acceleration is 9.80665 m/s^2 (32.174 ft/s^2) in a vacuum. However, this varies by about ± 0.3 percent depending on how far you are from the Earth's center of mass. Mass distorts space in such a way that the gravitational power of attraction is inversely proportional to the square of the distance between material objects (if non-gravitational forces are ignored). So, gravitational acceleration, "g" is greatest at the poles, least at the equator and decreases with altitude.

When we weigh a mass we are trying to find its weight expressed as pounds or kilograms. Because "g" and other factors vary from location to location, we must calibrate the scale whenever we move it, otherwise a mass of 30kg might display 30.00kg in one location and 30.08kg in another (i.e.: "g" may have changed by +0.267%. $w=m \times g$). This would be an error but it can be prevented by placing an accurate mass on the scale (say 30kg) and then telling the scale, in effect, "this is what 30kg weighs at this location so please display 30.00kg"..... this is calibration.

The HW-D indicator is also equipped with a gravity compensation function which means that it can be calibrated in one location and then adjusted to match the acceleration of gravity at another location. We call this "setting the value of g". If you wish to take advantage of this feature, please read the Gravity Compensation Function section.

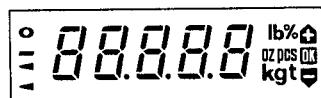

Display Check

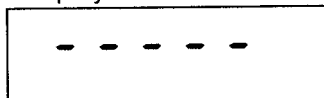

Bar display

Zero and span calibrations

Ensuring that there is nothing on the weighing platform, switch ON the power. If the bar display is shown after the display check, the zero point is displaced. In this situation, carry out the zero point calibration.

- (1) Press the ON/OFF key and allow an adequate amount of time for warming up (10 minutes or longer). During warming up, disable the auto power off function, or place an object on the weighing platform so that the display is not zero.

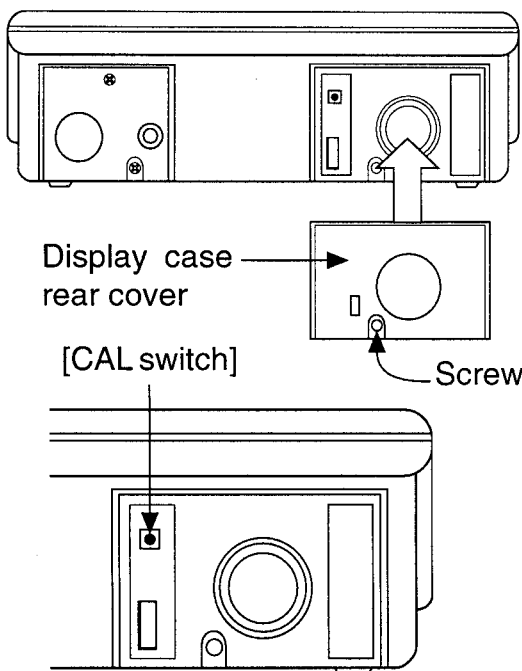

(2) Remove the calibration switch cover.

(3) Press the **CAL** key.
By pressing the **CAL** key, the calibration mode is entered and a four-digit value **9. ***** is displayed.

(2) Set the gravity acceleration according to the procedure "Correction for acceleration due to gravity". Set this to the gravity where the scale is being calibrated. After finishing this setting, press **ZERO**, the display enters the zero point calibration.

(3) Zero adjustment

Functions of the key switches used:

ZERO Stores the zero adjusting value in memory.

SET The data is not changed, and the machine moves forward to the span adjustment.

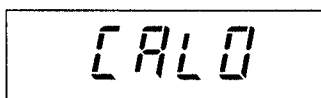

With nothing on the weighing platform, wait for the "O" stable mark to be displayed.

When this stable mark is displayed, press **ZERO** to store the zero data. When the data has been stored, the calibration mode moves forward to the span adjusting procedure.

If only the zero point is to be calibrated, press the **CAL** switch to exit from the calibration mode after the above procedure.

(4) Span adjustment

In span adjustment, there is a full scale adjusting mode and a 2/3 scale adjusting mode. Perform one or other of the procedures. (For each of the values, refer to the calibration weights in the table.)

If at all possible, carry out the adjustment using the full scale weights. Only carry out the adjustment using the 2/3 scale weights when unavoidable due to not having enough weights, etc.

Functions of the key switches used:

ZERO Stores the span data in memory.

MODE The data is not changed, and the span adjusting mode changes.
Each time the switch is pressed, the mode changes as follows:

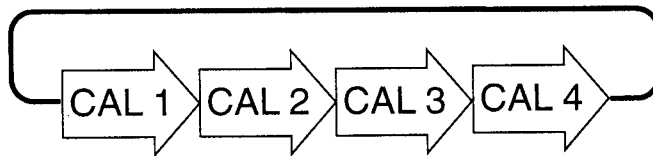

The CAL3 and CAL4 (pound) modes are only available when function F3 1 is set.

(5) Span adjustment (Full scale)

(1) 
or

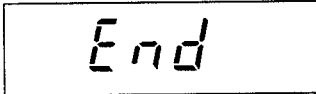

(2) 

By pressing the **MODE** switch, select either the CAL1 (Kg) or CAL3 (1b) modes.

Place the full scale weights on the weighing platform and wait until the "O" stable mark is shown.

When the stable mark is shown, press **ZERO** to record the span adjusting data. After the data has been recorded, "End" is automatically displayed.

(6) Span adjustment (2/3 scale)

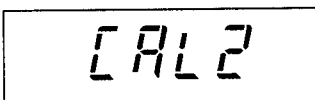
(1) 
or

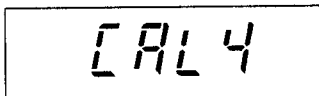

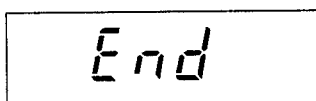
(2) 

By pressing the **MODE** switch, select either the CAL2 (Kg) or CAL4 (1b) modes.

Place the 2/3 scale weights on the weighing platform and wait until the "O" stable mark is shown.

When the stable mark is shown, press **ZERO** to record the span adjusting data. After the data has been recorded, "End" is automatically displayed.

(7) Ending the calibration

After the zero span adjustment is finished and "End" is displayed, if the calibration has been completed, press the **CAL** switch. This exits from the calibration mode and returns to the normal weighing display mode.

To complete the calibration, replace the calibration switch cover that was previously removed.

Note: If the scale is to be used in a location other than where it was calibrated and the "g" setting for that area is different, re-enter the calibration procedure and set the "g" for that area. See Appendix for a list of gravity settings at various locations. If in doubt, contact your local Office of Weights and Measures for this data.

Error displays during calibration

(8) Error displays

The following are the error displays that may be shown during calibration. If these displays are shown, confirm whether the operation has been mistaken and if the correct weights are being used, etc., then switch off and perform the procedure again.

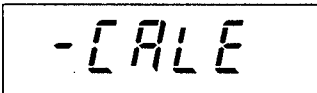
(1) 

The output from the load cell is too small. When carrying out the span adjustment, if this error is only displayed when the **ZERO** switch is pressed, the load cell output is too small compared to the zero adjusting data.

(2) 

The load cell output is too large. Check the weight value of the calibration mass and the calibration mass settings (steps 5 and 6 of the calibration procedure).

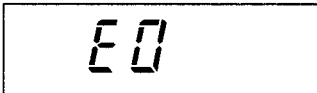
(3) 

The data that was to be stored in memory has not been stored correctly.

For the span adjustment, use an accurate weight to carry out the procedures.

Calibration Weight Table

Capacity (kg)	CAL1 (kg)	CAL2 (kg)	CAL3 (lb)	CAL4 (lb)
30.00	30.00	20.00	60.00	40.00
60.00	60.00	40.00	120.00	80.00
150.00	150.00	100.00	300.00	200.00
15.000	15.000	10.000	30.000	20.000
100.00	100.00	60.00	200.00	150.00
10.000	10.000	6.000	20.000	15.000
300.00	300.00	200.00	600.00	400.00
600.0	600.0	400.0	1200.0	800.0
1200.0	1200.0	800.0	2400.0	1600.0
31.00	30.00	20.00	60.00	40.00
30.000	30.000	20.000	60.000	40.000

POWER SOURCES

For the power source, it is possible to use dry cell batteries (six "C" size dry cell batteries), the AC adaptor or an optional NiCd battery pack (AD-1681: sold separately).

- When using the AC adaptor:
If the power source used is unstable and is liable to momentary power cuts, or if the power source includes a noise component, there is a possibility that mis-operation may occur. To avoid this possibility, use a stable power source.
When using the AC adaptor, the dry cell batteries can not be used. If using the AC adaptor for a long period, remove the batteries.
- When using dry cell batteries:
Insert the batteries into the battery box, then insert the battery box into the display pod.

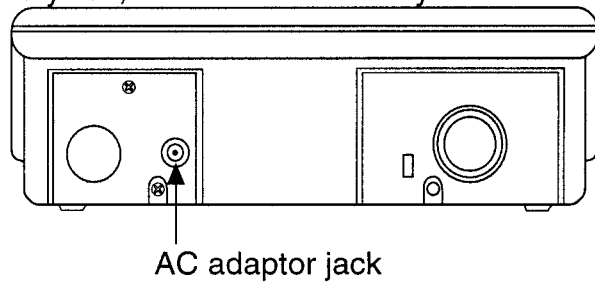

Battery box

At the time of shipping, the battery box is inserted in the main unit.

To remove the battery box, press it in and up, then slide it out.

When inserting the batteries into the box, take care to ensure correct battery polarity.

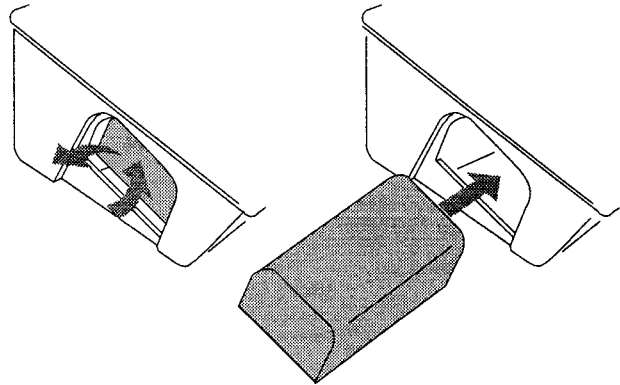

- When using the NiCd battery pack
Insert the NiCd battery pack in place of the dry cell battery box.

When re-charging, remove the AD-1681 and re-charge with the supplied charger. For an empty battery, it will take about 15 hours for charging. When the charging is finished, detach the charger as soon as possible to avoid over-charging the battery.

The AC adaptor used for the indicator cannot be used for charging the NiCd battery. Be sure to use the supplied charger for recharging. In the same way, the charger can not be used to power the indicator. Use the supplied AC adaptor.



PANEL PARTS NAMES & FUNCTIONS

FRONT PANEL

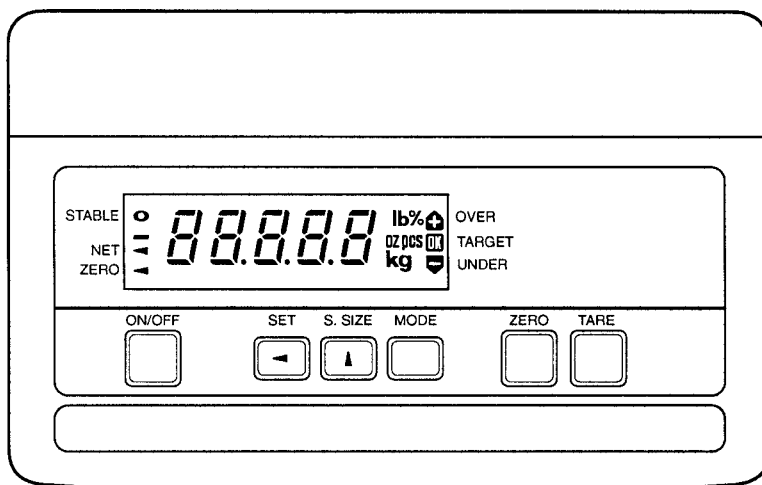

ON/OFF

Power **ON/OFF** switch.

After power on, if zero continues to be displayed for about 3 minutes, this machine will automatically switch itself off. This automatic power off function can be disabled using the function settings.

SET

This switch has the following four functions:

- (1) Counting mode:
Used for recording the unit weight of the sample.
- (2) % Percentage mode:
Used to record the sample as the 100% weight.
- (3) Comparator **ON/OFF**
In weighing display mode, this switch is used to switch the comparator function on and off .
- (4) Setting the upper and lower limit values
For the upper and lower limit values displayed using the **MODE** switch, the required figure that is to be changed can be set using this **SET** switch.
Each time the key is pressed, the digit to be changed will be moved one digit to the left and will flash.
(Changing of the value of the digit is carried out using the **S.SIZE** switch.)

S.SIZE

This switch has the following two functions:

- (1) In counting mode:
Changes the sample size.
The sample size is normally 5 units, but it is also possible to set 10 units, 20 units, 50 units or 100 units.
- (2) Setting the upper and lower limit values:
After selecting the digit using the **SET** switch, the **S.SIZE** switch is used to change the digit value.
Each time the key is pressed, the value (or sign) will change.

MODE

This switch is used to change between the displayed units and to set the upper and lower limits.

The units can be changed as follows:

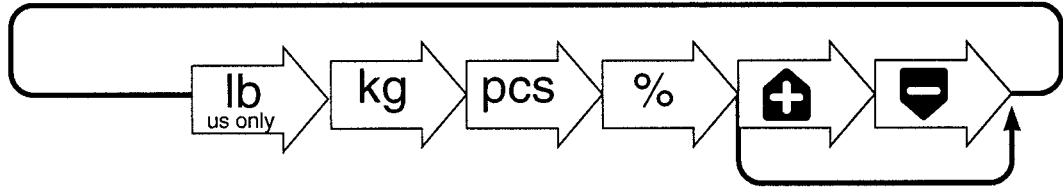

If the comparator function is not ON, the upper limit value and lower limit value will not be displayed.

The lb. units are only available when function F3 1 is set.

ZERO

Sets the display to zero. This function is valid when the stable mark is displayed, and is valid within a range of ± approximately 2, 5 or 10% of the center weight at power on (depends on F2 setting).

TARE

By pressing this switch, the indicator subtracts the tare to give net weights, and the display is set to zero.

Further, by removing the object that has been placed on the scale and pressing this switch, the tare subtraction can be cleared.

This switch is valid for use when the stable mark is displayed, and the range is up to the maximum capacity.

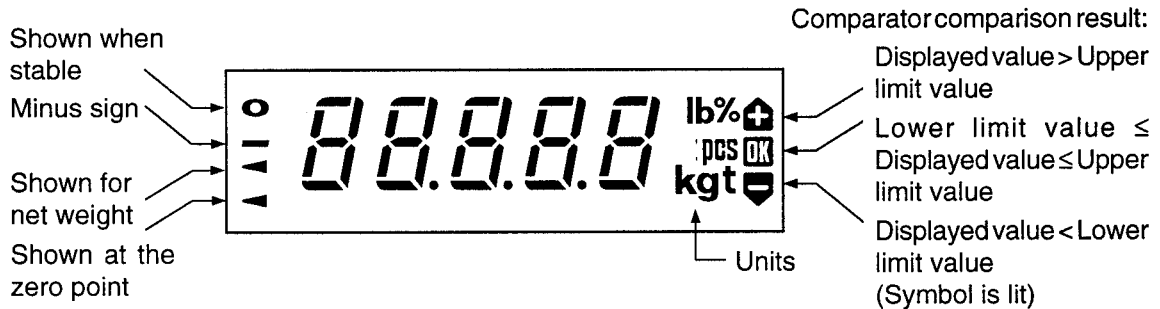

Display:

Weight overload displays:

Plus overload

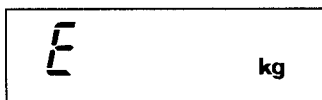

Displayed when a load is applied that exceeds the maximum weight.

Minus overload

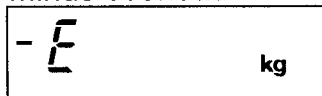

Displayed if at power on the zero fluctuates approximately the % set in F2, in the minus direction.

REAR PANEL

- ❑ Calibration switch:
- ❑ Load cell connector:
- ❑ AC adaptor jack:

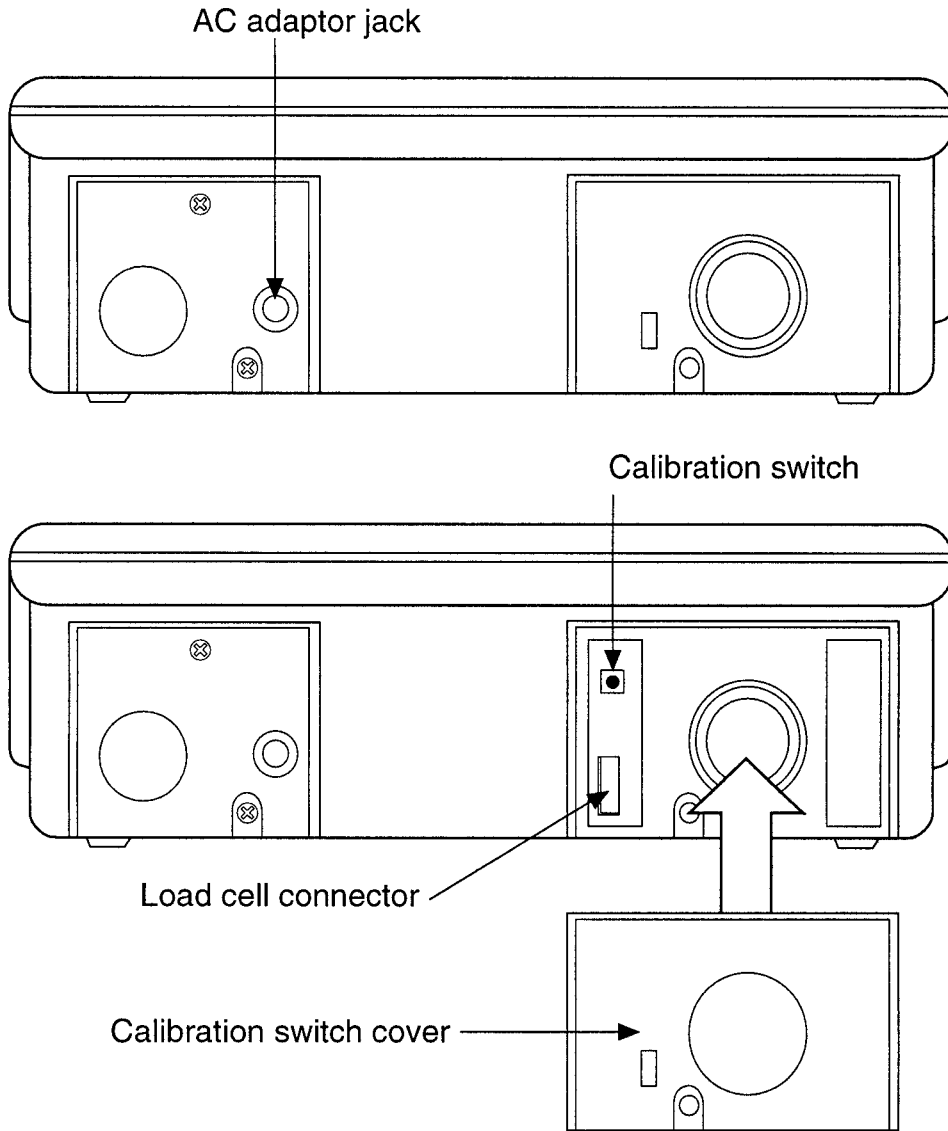

METHOD OF USE

STARTING

- (1) Ensure that there is nothing on the weighing platform.
- (2) Switch ON the power.
(Press the **ON/OFF** switch.)



Display check
(All the display segments light for 3 seconds.)

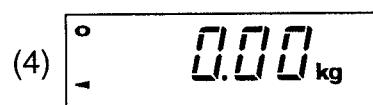

(If function F3 1 is set, the displayed units are lbs.) and by pressing the **MODE** switch the displayed units can be selected as "kg" or "lb".

The scale can now be used for weighing

- (5) To Switch OFF
(Press the **ON/OFF** switch again.)

WEIGHT DISPLAY ("kg", "lb.") MODE

- (1) Press the **ZERO** switch to set the zero.

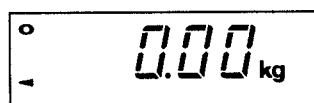

- (2) If a tare (container) is being used, place the container on the weighing platform. When the "O" stable mark is displayed, press the **TARE** switch to set the zero point.

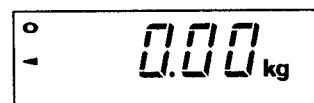

- (3) Place the sample that is to be weighed on the weighing platform and read out the numerical value when the "O" stable mark is displayed.

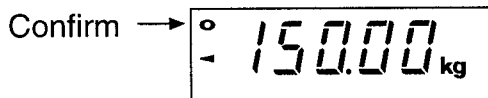

COUNTING (“pcs”) MODE PARTS COUNTING

- (1) Press the mode switch until the displayed units change to “pcs”.

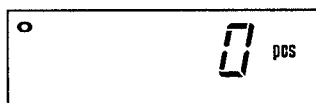

Place the samples on the weighing platform, and the counting will begin.

- (2) The unit weight previously input will be used to calculate the number of units, and this number will be displayed.

RECORDING THE UNIT WEIGHT

- (1) In counting mode, by pressing the **SET** switch, it is possible to record a new unit weight.

To discontinue the recording process, press the **MODE** switch to exit from the counting mode.

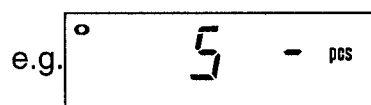

5 unit sample

- (2) Press the **S.SIZE** switch and select the number of units to be used as the standard. The 5 types of samples that can be used as the standard are 5, 10, 20, 50 or 100 units. Note that a larger sample will give greater accuracy.

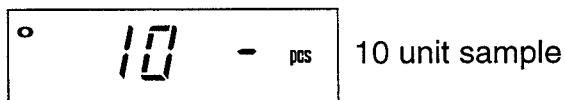

10 unit sample

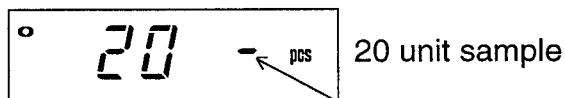

20 unit sample

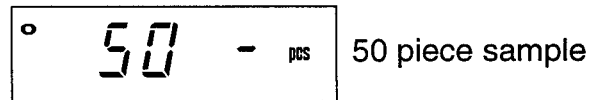

50 piece sample

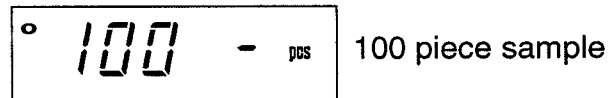

100 piece sample

Note: The display of this symbol indicates that either there are objects on the weighing platform, or else that the zero point is disturbed. If there is no load on the weighing platform when this display is shown, press either the **ZERO** switch or the **TARE** switch to set the zero point.



- (3) Set the zero point as described.

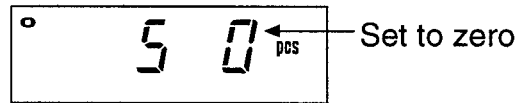

- (4) Place the selected number of samples on the weighing platform.

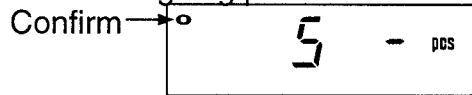

- (5) After confirming that the "O" stable mark is displayed, press the **SET** switch. The average weight of the sample will be recorded as the unit weight, and the number of units can be weighed.

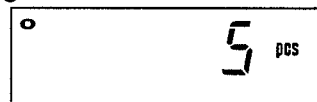

- (6) If Lo is displayed when the **SET** switch is pressed in (5), this indicates that the sample weight is less than the unit weight that is possible to be counted.

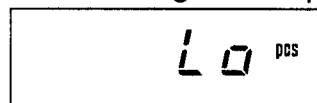

- (7) The recorded unit weight is stored and will not be deleted, even by switching off the power.

- * When shipped from the factory, the unit weight was set to zero.

COMPARATOR COMPARATOR FUNCTION

- (1) The comparator function operates in weighing, counting and % percentage modes. If the displayed value is greater than the upper limit value, "⊕" is displayed, and if it is less than the lower limit value, "⊖" is displayed. "OK" will be displayed when the value is between the upper limit and lower limit values.

⊕ > Upper limit value ≥ OK ≥ Lower limit value > ⊖
 "⊕" is displayed for a plus overload (E display), and "⊖" is displayed for a minus overload (-E display). If the data output option (OP-03) is installed, "+", "OK" and "-" signals can be output.

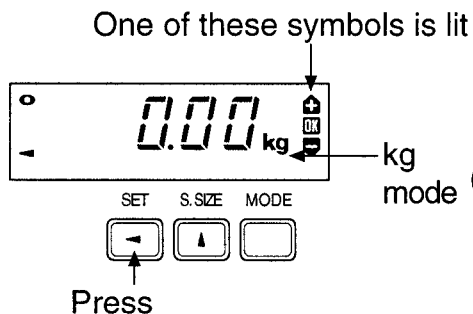

- (2) To switch on the comparator in weight display mode, press the **SET** switch. (It is not possible to switch on the comparator in counting mode.) One of the "⊕", "OK", "⊖" signs will light to show that the comparator is in the operating condition.

- (3) To switch OFF the comparator function in weight display mode, press the **SET** switch once again.

SETTING THE UPPER & LOWER LIMIT VALUES

e.g. If the display is set to "10000":



Position of the decimal point for "kg" units in weight display mode (not displayed).

Note: When setting these values, the decimal point is not shown. In the example in the figure at left, because there is no decimal point in counting mode, the display is as shown.

For example, for a display of 10000, in "kg" weight display mode this would be 100.00kg, and in counting mode it would be 10000 pieces.

Note: In the above conditions, because the same memory is used for the weighing display, counting and % percentage modes, it is not possible to set or use independent values for each mode.

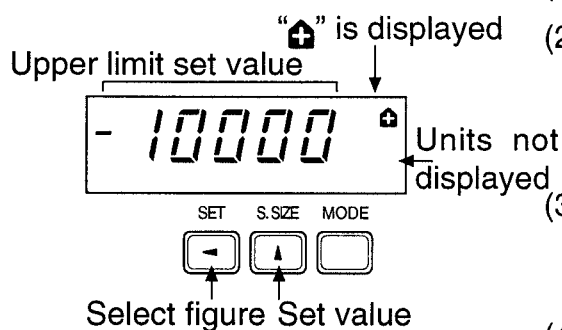

(1) Upper limit

- (1) Switch on the comparator function.
- (2) Press the **MODE** switch to enter the upper limit setting mode. When the setting mode is entered, the units are not displayed, and instead the currently set value and "🔒" are displayed.
- (3) If the currently set value is not to be changed, press the **MODE** switch to move forward to the lower limit setting mode.
- (4) To change the currently set value, press the **SET** switch to select the digit to be changed, then press the **S.SIZE** switch to change the value. The digit selected by the **SET** switch will flash to show that it is selected, but after pressing the **S.SIZE** switch the flashing will stop.
- (5) When the setting of the upper limit value is finished, press the **MODE** switch to move on to the lower limit setting mode.

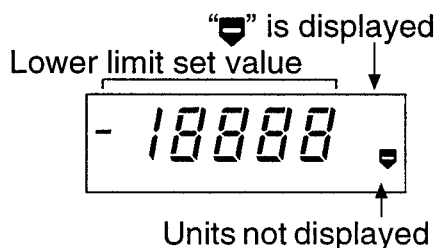

(2) Lower limit

- (1) Using the same method as for the upper limit, set the lower limit value. However, ensure that the upper limit value \geq the lower limit value.
- (2) After completing the setting, press the **MODE** switch to exit from the setting mode. At this time, the set upper and lower limit values will be automatically stored in memory.

% PERCENTAGE MODE

% PERCENTAGE DISPLAY

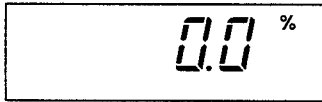

- (1) Press the **MODE** switch to set the units display to “%”.
- (2) By placing an object on the weighing platform, the percentage weight of the object compared to a previously recorded 100% weight value will be displayed.

4-5-2 Recording the 100% weight

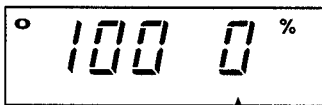
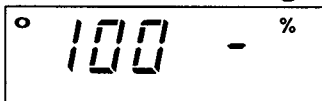

Set to zero

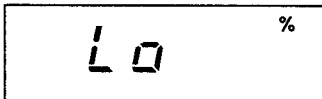
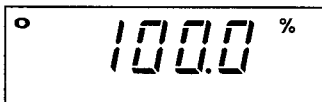

- (1) By pressing the **SET** switch in % mode, a new 100% weight can be recorded. To discontinue the recording, press the **MODE** switch to exit from the % percentage mode.
- (2) If “-” is displayed on the right hand side of the 100 value, this shows either that the zero point is displaced, or that the tare on the weighing platform is not displaying zero.
- (3) Set the zero using the methods in 4-2 (1) or 4-2 (2).
- (4) Place the sample that is to be set to 100% on the weighing platform. After confirming that the “O” stable mark is displayed, by pressing the **SET** switch the weight will be stored in memory and displayed as the 100% weight.
- (5) If when the **SET** switch is pressed in step (4), “Lo” is displayed, this shows that the sample weight is less than the weight possible to be stored as the 100% weight.
- (6) The stored unit weight is not deleted even after switching off the power.

Note: If for, example, a lower limit value of 1000 has been set in the comparator, in this percentage display, the value will be treated as 100.0%.

6. Changing the batteries

Low battery display

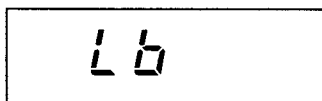

If “Low battery” is displayed during use, discontinue use and either replace the batteries or use the AC adaptor.

OPTIONS & ACCESSORIES

The following options and accessories are available:

- (1) OP-03 Data output board
- (2) AX-WM-B31727 Wall mounting fixture
- (3) AD-1681 NiCd battery pack

For the handling of the AD-1681, please read the manual included with the option.

OP-03 DATA OUTPUT (RS-232C and comparator output)

The RS-232C and comparator outputs are available from the same connector.

RS-232C SECTION

This interface is used to connect the HW-D indicator to the AD-8121 compact printer or a personal computer. The RS-232C has two modes, either of which can be set using the F5-2 function setting.

(1) Stream mode

The value being displayed is output normally, and the data sending speed is four or five times per second. However, there is no output while setting the unit weight in counting mode, while setting the 100% weight in % percentage mode, and while setting the comparator upper and lower limits.

When the AD-8121 compact printer is connected, set the stream mode.

(2) Command mode

Commands can be sent from a personal computer, etc. to the indicator, causing the displayed data to be output and allowing zero setting and tare subtraction to be carried out.

The commands that can be used are as follows:

T term: The tare subtraction operation is carried out only when the display is stable.

Z term: The zero operation is carried out only when the display is stable.

Q term: Regardless of the stability or instability of the display, output the displayed data one time. However, output is not carried out while the unit weight is being set in counting mode, or while setting the 100% weight in % percentage mode.

U term: Switch between the units. Each time the command is sent, the units change as follows:

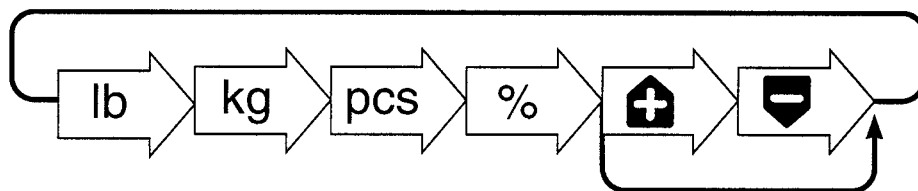

If the comparator function is not on, the upper limit and lower limit values will not be displayed. The lb. display is only available when function F3 1 is set.

- * "term" represents terminator. Using the 5-2 function setting, set either CR+LF or CR to match the type of personal computer, etc. that is connected. When sending a command continuously, ensure that there is an interval of 500msec or longer between the commands.

(3) Interface specifications

Output standards:	According to EIA RS-232C
Transmission format:	Start/stop synchronous transmission
Signal speed:	2400bps (fixed)
Data bit length:	7 bits
Parity:	1 bit (even)
Stop bit:	1 bit
Code:	ASCII

(4) Data format

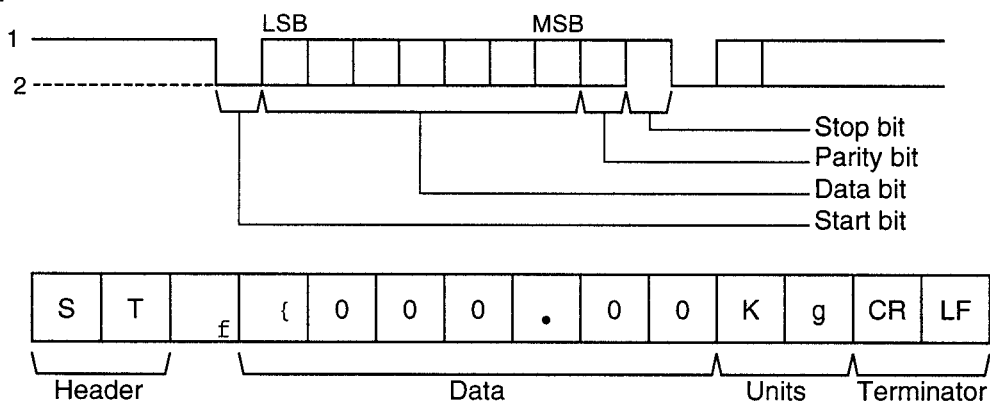

- There are the following six types of headers:
 - ST In weighing mode and % percentage mode, the data is stable.
 - QT In counting mode, the data is stable.
 - US Data is unstable.
 - OL Data is overloaded (the maximum display is exceeded)
 - HI Upper limit value Only used in command mode
 - LO Lower limit value
- The data is a 7 figure value when including the sign and decimal point. If there is no decimal point, the data will be 6 figures long.
When the data is overloaded, "+999.99" or "-99.999" will be output. (The position of the decimal point will be different depending on the setup and the displayed units.)
- There are the following types of units:
 - kg Weight display mode (kg)
 - lb Weight display mode (lb)
 - PC Counting mode
 - % % Percentage mode
 - Upper limit value and lower limit value
- Regardless of the function setting, CR+LF is output as the terminator.

(5) Interface circuit

Uses a DIN 8 pin connector

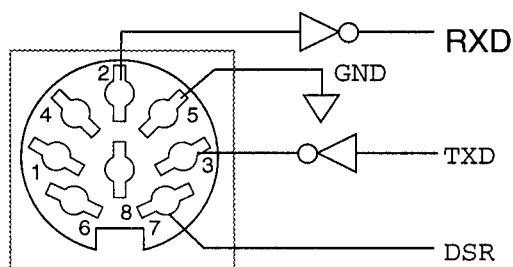

Internal connection diagram

- * Short the RTS and CTS pins of the connected personal computer.

COMPARATOR SECTION

Outputs the comparator function +, OK and - signs to an external unit.

When outputting the +, OK and - signs, it is possible to select whether to output the data only when it is stable, or to output data even when it is unstable. Further, it is possible to prohibit the data output when the data is close to zero (-4 units ~ +4 units). (Refer to page 5, function settings.)

Because this option is also provided with a buzzer, it is possible to have buzzer output at the same time as the +, OK and - signs. Whichever of the +, OK and - output signals are to have the buzzer output can be selected with the switches.

Dip switch settings:

Dip switch settings		
1	OFF	Stable only, contact output: No buzzer
	ON	Normal, contact output: Buzzer output
2	OFF	When minus (-): No buzzer
	ON	When minus (-): Buzzer output
3	OFF	When OK: No buzzer
	ON	When OK: Buzzer output
4	OFF	When plus (+): No buzzer
	ON	When plus (+): Buzzer output

Refer to p.28
Dip switches.

Internal connection diagram

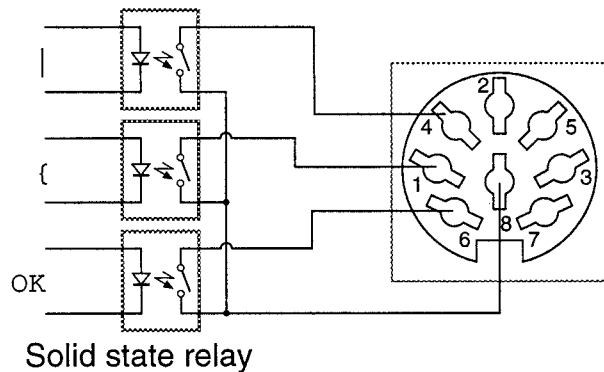

The absolute maximum rating of the contact is as shown below:
Use the contact in a way that does not exceed these values.

- Maximum voltage: 50V or less
- Maximum current: 100mA or less
- Maximum ON resistance: 8Ω or less

Method of mounting the data output board

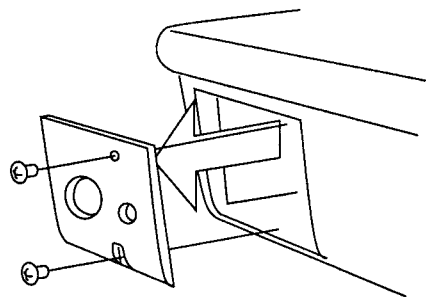

(1) Take out the two screws and remove the cover.

(2) Cut the cable clamp which secures the cable to the cover.

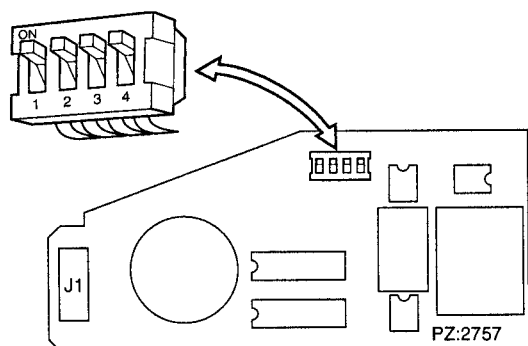

(3) After setting the dip switches on the data output board according to 8-2-2 Dip switch settings, connect the cable to J1.

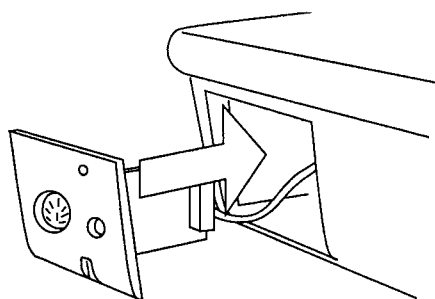

(4) Insert the data output board into the main unit.

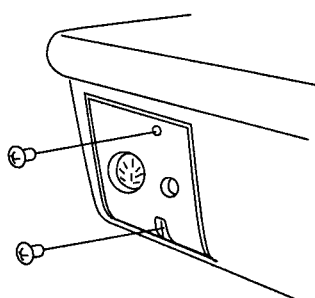

(5) Install the cover with the two screws.

AX-WM-B31727 Wall mounting fixture

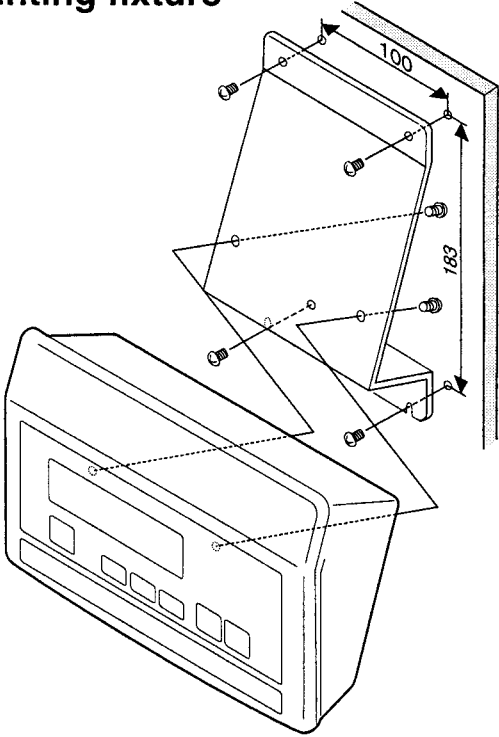

Appendix

Gravity Values at Various Locations

Calcutta	9.788	m/s ²	Paris	9.809	m/s ²
Capetown	9.796	m/s ²	Rio de Janeiro	9.788	m/s ²
Chicago	9.803	m/s ²	Rome	9.803	m/s ²
Amsterdam	9.813	m/s ²	Manila	9.784	m/s ²
Athens	9.800	m/s ²	Melbourne	9.800	m/s ²
Auckland NZ	9.799	m/s ²	Mexico City	9.779	m/s ²
Bangkok	9.783	m/s ²	Milan	9.806	m/s ²
Birmingham	9.813	m/s ²	New York	9.802	m/s ²
Brussels	9.811	m/s ²	Oslo	9.819	m/s ²
Buenos Aires	9.797	m/s ²	Ottawa	9.806	m/s ²
Copenhagen	9.815	m/s ²	San Francisco	9.800	m/s ²
Cyprus	9.797	m/s ²	Singapore	9.781	m/s ²
Djakarta	9.781	m/s ²	Stockholm	9.818	m/s ²
Frankfurt	9.810	m/s ²	Sydney	9.797	m/s ²
Glasgow	9.816	m/s ²	Taichung	9.789	m/s ²
Havana	9.788	m/s ²	Taiwan	9.788	m/s ²
Helsinki	9.819	m/s ²	Taipei	9.790	m/s ²
Kuwait	9.793	m/s ²	Tokyo	9.798	m/s ²
Lisbon	9.801	m/s ²	Vancouver, BC	9.809	m/s ²
London (Greenwich)	9.812	m/s ²	Washington DC	9.801	m/s ²
Los Angeles	9.796	m/s ²	Wellington NZ	9.803	m/s ²
Madrid	9.800	m/s ²	Zurich	9.807	m/s ²

Acceleration Due to Gravity Table

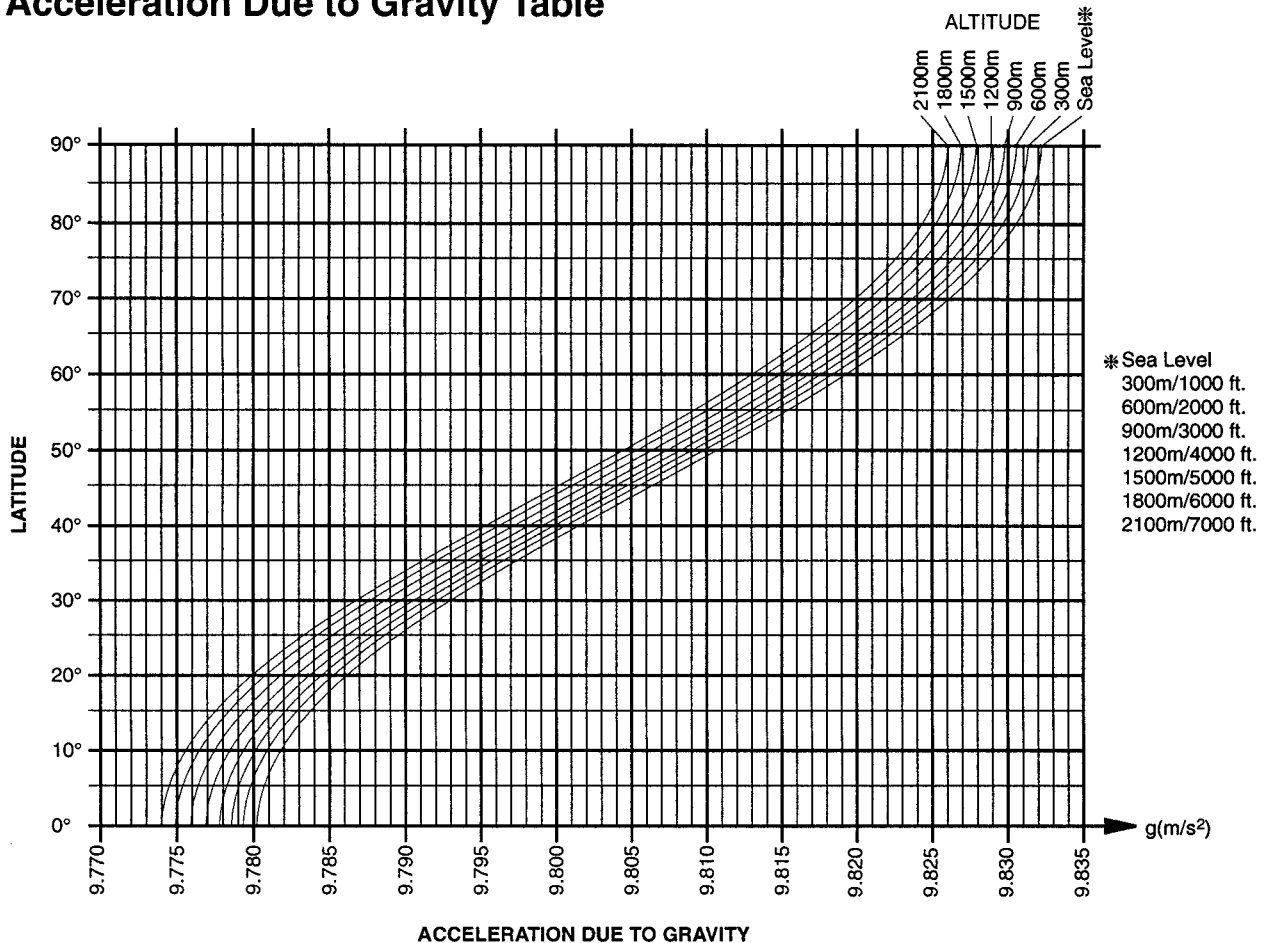

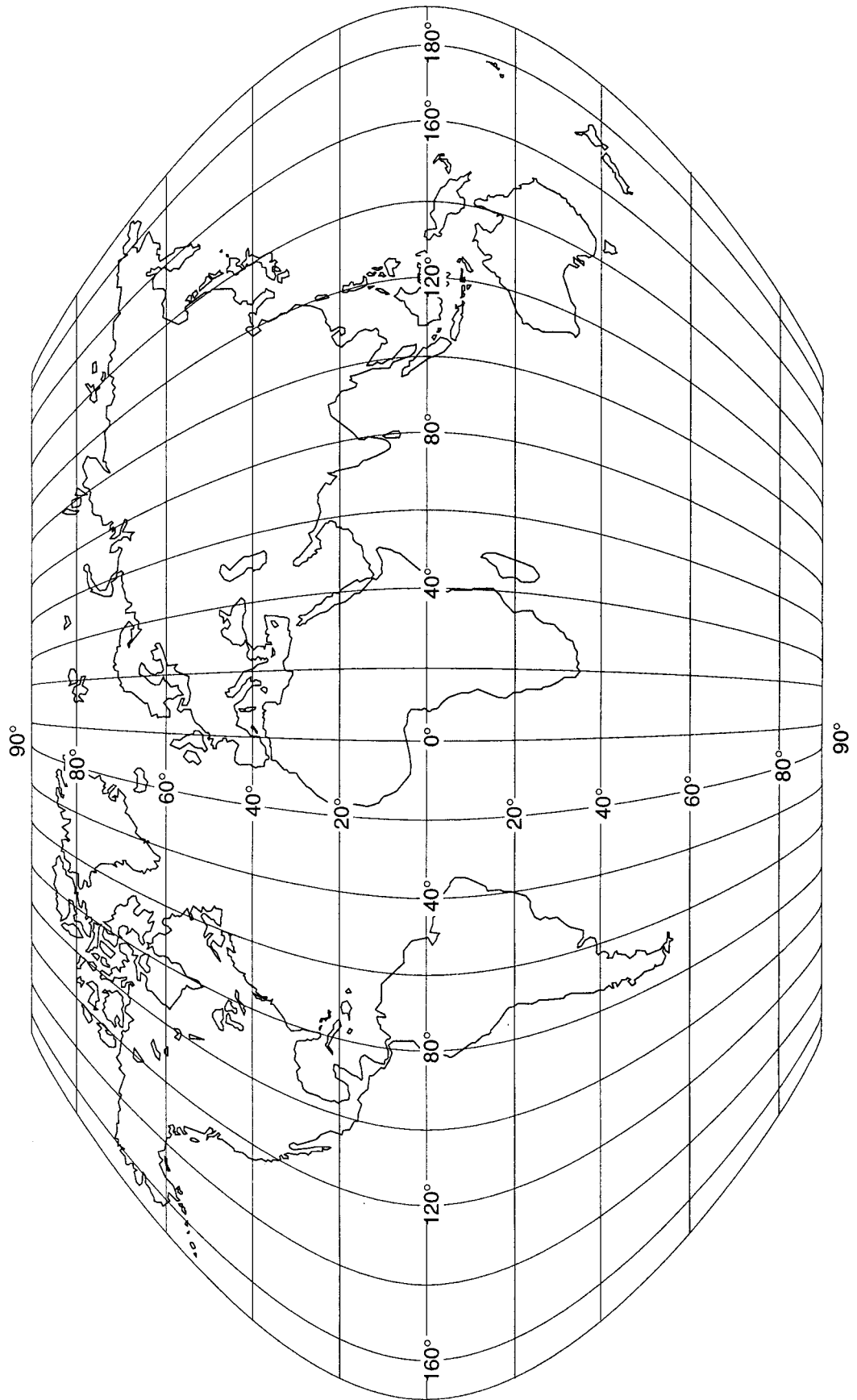



A&D MERCURY PTY. LTD.

Head Office

32 Dew Street
THEBARTON
South Australia 5031

Tel: (08) 8352 3033

Fax: (08) 8352 7409

E Mail : sales@mail.andmercury.com.au

Internet page : <http://www.andmercury.com.au>

Victorian Office

Unit 4
Corner Arden & LLoyd Streets
KENSINGTON
Victoria 3031

Tel: (03) 9372 1522

Fax: (03) 9372 1193

New South Wales Office

Unit 2
49 Derby Street
SILVERWATER
New South Wales 2128

Tel: (02) 9748 4766

Fax: (02) 9748 4724