

HM SERIES

INSTRUCTION MANUAL

PRECISION ELECTRONIC BALANCE

HM-120

HM-200

HM-202

HM-300



This is hazard alert mark.



This informs to you about the operation of the balance.



This is a notice about the operation of the balance.



Contents

Introduction	3
Features	3
Options and Accessories	3
Compliance with FCC Rules	3
Unpacking your Balance	4
Balance Location	5
Best conditions for weighing	5
Setting up your Balance	6
Taking care of the Balance	6
Power Supply	6
Display ON:OFF & Power Errors	6
Keys and Displays	7
Displays	7
Keys	7
Units	8
Weighing Units and their Conversions	8
Selecting the Weighing Units	9
Weighing	10
Simple Weighing	10
Counting Mode (pcs)	11
Selecting the quantity to be used as a sample	12
ACAI Automatic Counting Accuracy Improvement	13
ACAI Notes	14
Counting Mode using Digital Input of Unit Weight	15
Percent Mode (%)	16
Percent Mode (%) with Digital Input of 100% Weight	17
Environment Response Adjustment	18
Conditions of response	18
Calibration	19
Displays and cancelling calibration	19
One Touch Calibration	20
One Touch Calibration Test	21
Manual Calibration	22
Manual Calibration Test	24
To correct a value of internal calibration mass	26
Calibration on the error	27

Functions	-----28
C-parameter keys and displays	-----28
Internal parameter setting	-----29
C-parameter settings	-----30
Miscellaneous	-----32
Digital Tare	-----32
The ID number	-----33
External key connector	-----34
Underhook weighing	-----35
An example of underhook weighing	-----35
Specifications	-----36
Specifications	-----36
External Dimensions	-----37
Errors	-----38
Index	-----40



Introduction

*Thank You For Your **AND** Purchase*

Electronic Balances are easy to use, yet they are rather complex in that they are high technology products. This manual will tell you in simple language how this balance works and how to get the most out of it in terms of performance.



Features

- The HM-202 is dual range balance (42g x 0.01mg/ 210g x 0.1mg).
- The HM-120, HM-200 and HM-300 are single range balances.
- The HM series can be easily adapted to most operating environments through simple adjustments from the keyboard.
- The OP-03 serial interface allows control of the balance or transmission of the weighing data to a computer or printer.
- Good Laboratory Practices (GLP) calibration output using the OP-03 / 05 serial interface.
- A calibration mass correction function allows precise input of the calibration mass.
- Multiple weighing units, with most of the common units used around the world.
- Counting (pcs) mode, for inventorying lightweight components or pharmaceuticals.
- Percent (%) mode, for matching weights against a standard.
- Digital Tare, allows the input of a tare value from the keyboard or via the RS-232C interface.
- Security, the serial number of the balance is available using the RS-232C interface.



Options and Accessories

- OP-03 Serial interface, bi-directional RS-232C/ Current Loop.
- OP-05 Current Loop printer interface.
- OP-11 Anti-theft device.
- AD-8121 multi-function printer. This printer can print weighing data, total weighing counting and standard deviation, along with the time and date. Includes statistical calculation.



Compliance with FCC Rules

Please note that this equipment generates, uses and can radiate radio frequency energy. This equipment has been tested and has been found to comply with the limits of a Class A computing device pursuant to Subpart J of Part 15 of FCC rules. These rules are designed to provide reasonable protection against interference when equipment is operated in a commercial environment. If this unit is operated in a residential area it might cause some interference and under these circumstances the user would be required to take, at his own expense, whatever measures are necessary to eliminate the interference. (FCC = Federal Communications Commission in the U.S.A.)



Unpacking Your Balance

- ❑ Unpack the balance carefully and keep the packing material if you want to transport the balance again in the future.
- ❑ In the carton you should find this manual plus:

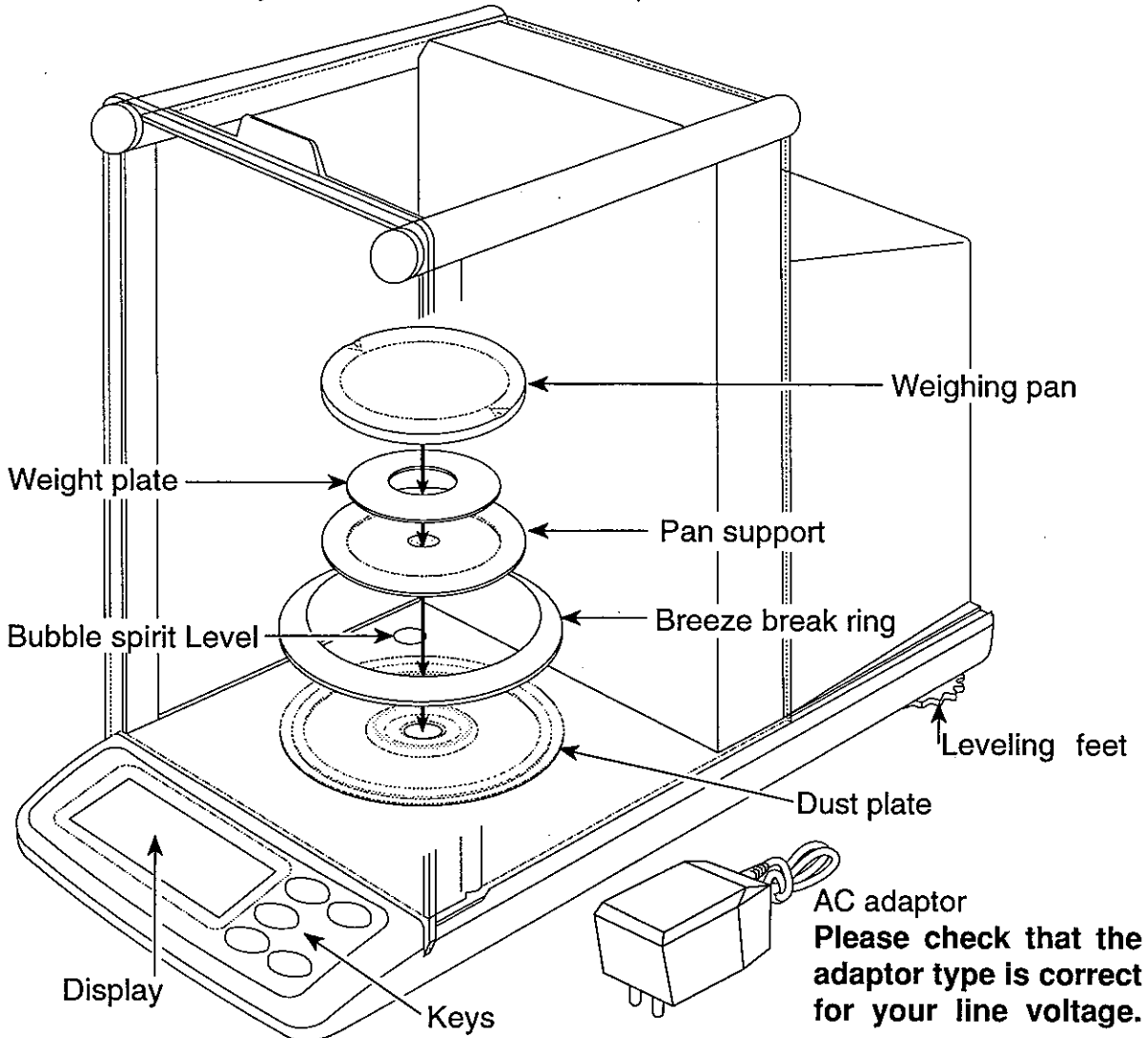

Options & Accessory

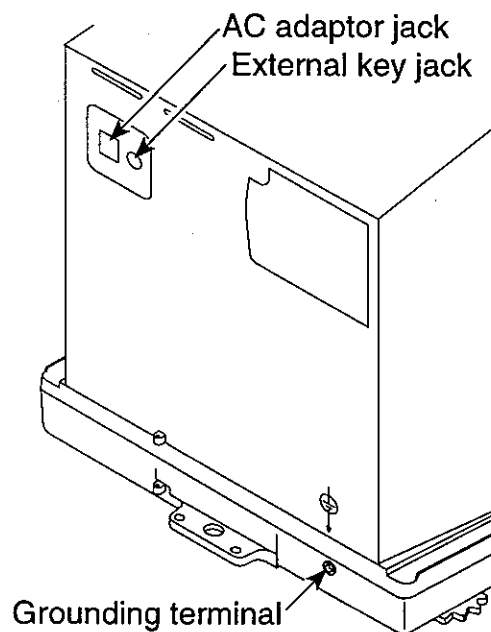
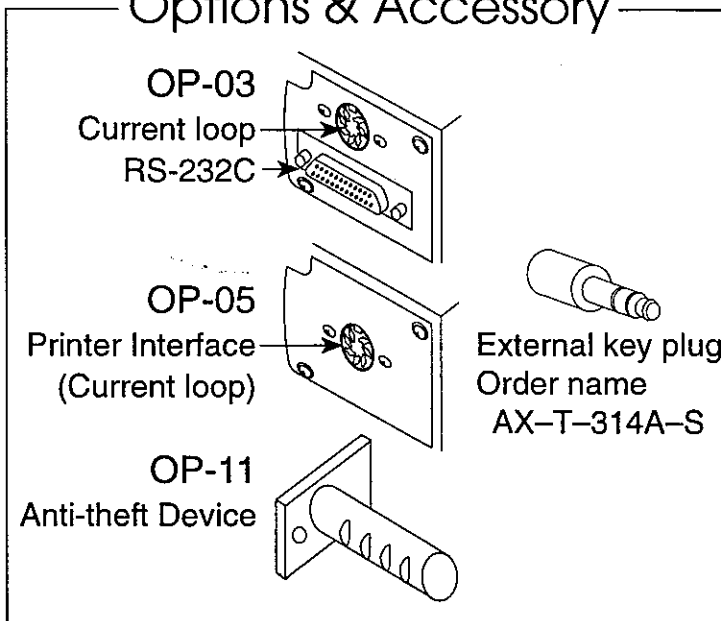



Balance Location

- The weighing table should be solid and free from vibration, drafts (such as frequently opening doors or windows) and as level as possible.
- Corners of rooms are best as they are less prone to vibrations.
- Don't install the balance near heaters or air conditioners.
- Don't install the balance in direct sunlight.
- Don't use the balance near other equipment which produces magnetic fields.
- Try to ensure a stable power source when using the AC adaptor.
- The best operating temperature is about 20°C/68°F at about 50% Relative Humidity.



Best Conditions for Weighing



To ensure that you get the most from your balance, please try to follow these conditions as closely as possible:

- Please warm-up (plug-in) the balance for at least one hour.
- The weighing room should be kept clean and dry.
- Please RE-ZERO the balance before each use to prevent possible error.
- Make each weighing quickly to avoid errors due to changes in environmental conditions.
- Close the breeze break doors to keep out drafts.
- Do not drop things upon the weighing pan, or place a weight beyond the range of the balance on the weighing pan.
- Do not use a sharp instrument (such as a pencil or ball point pen) to press the keys, use only your finger.
- Use caution when weighing items that could have a static charge (plastics, insulator, etc.), as the weight of a material that has a static charge is influenced by its surroundings. Try to keep the ambient humidity above 45%RH.
- This balance uses a strong magnet as part of the balance assembly, so please use caution when measuring magnetic materials. If there is a problem, use the underhook assembly (on the bottom of the balance) to suspend the material away from the influence of the magnet.
- When weighing a sample that is either warmer or cooler than the ambient temperature, the sample can set up a draft due to the air rising or falling next to the sample. This draft can cause a shift in the weight of the sample.
- Due to the affect of air buoyancy on a sample, please take this into account when absolute accuracy is required.
- There are two methods of pressing a key. The first, is to press and release a key; and the second, is to press and hold a key. Each of these will perform a different function. Please refer to other sections of this manual to learn the functions of the keys. Take special care with the RE-ZERO key, because if it is pressed and held, the balance will enter the calibration mode which could cause you to reset calibration improperly.

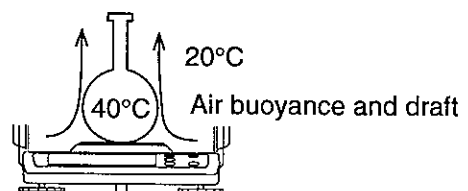
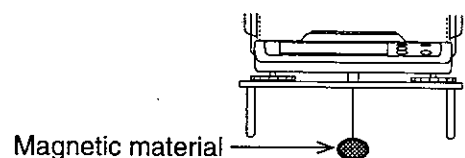
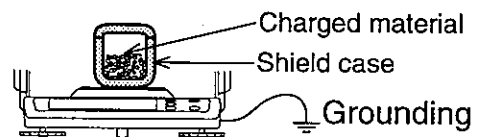

Setting Up the Balance

- Place the balance on a firm weighing table and turn the adjustable feet until the balance is level (check the spirit level on the balance).
- Install the weighing pan and breeze break ring on the balance (see the section on "Unpacking Your Balance").
- Please check that the adaptor is the correct voltage. Plug in the AC adaptor. Ground the balance chassis for electrostatic discharge if static electricity could be a problem.

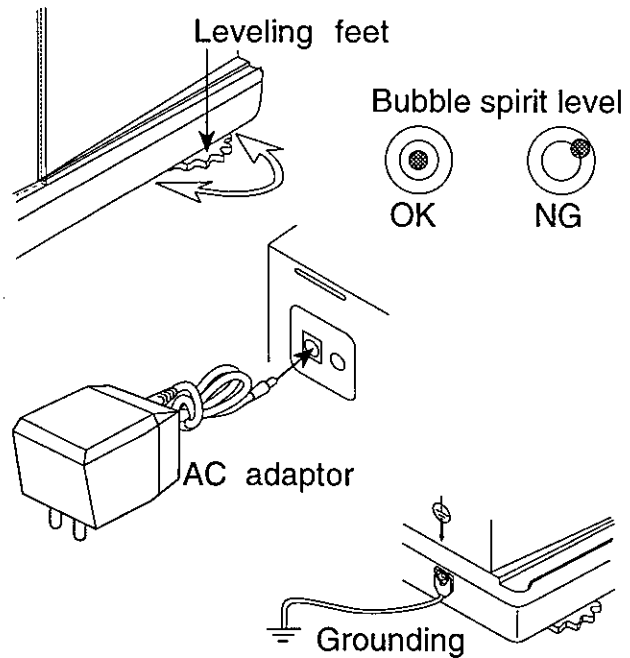

Taking Care of the Balance

- Don't disassemble the balance. Contact your local A&D dealer if your balance needs service or repair.
- Don't use solvents to clean the balance. A lint free cloth is best for cleaning, using warm water with a mild detergent.
- Keep equipment containing magnets away from the balance.
- Protect the internal parts from liquid spills and excessive dust.
- Please use a very precise calibration mass.

Power Supply

When the AC adaptor is connected, the balance is in the standby mode if the standby indicator is on (see "Displays" on the next page). This is a normal state and does not harm the balance. We recommend that you plug in your balance for at least an hour before use so it can warm up.

Display ON:OFF & Power Errors

- The balance does a self check when you connect the AC adaptor or press the **ON:OFF** key. If there is a problem, you will get an error display. Please refer to the error code table. P FR IL will be displayed if the power was cut with the display on. To clear this error, press the **ON:OFF** key.



Keys and Displays



This section explains the keys and displays for the weighing mode. Refer to the following separate sections for an explanation of Percent (%) Mode, Counting (pcs) Mode.



Displays

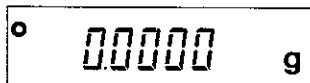

Normal weighing display of zero. Please read weighing data only after the stabilization mark is displayed.

Note: the number of decimal places depend on the model in use (HM-200 illustrated).

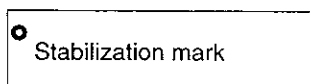

Stabilization mark

This round symbol is the stabilization mark. It is displayed when the balance is stable and the weighing data can be read. Refer to "Stability Band Width" Function.

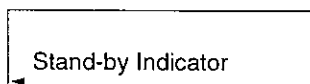

Stand-by Indicator

This is the Stand-by Indicator. This mark is displayed when you turn the display off, and the AC adaptor still connected.



Keys



ON:OFF

The **ON:OFF** key switches the display ON and OFF but does not cut the power to the balance. The balance will remain on standby (warm up) while the AC adaptor remains connected.

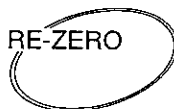

RE-ZERO

The **RE-ZERO** key is used to zero the display within the range of the balance. This key returns the balance to the center of zero when the weighing pan is empty, and can also tare total weight (container and sample). Please use this key before each weighing to cancel possible error.



RANGE

The **RANGE** key can also be used to turn ON/OFF the last significant digit alternately. This key switches the weighing range for the HM-202.

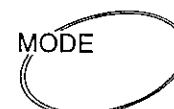

MODE

If you press the **MODE** key, the balance switches between weighing modes. However, only selected modes will be displayed.

If you press and hold the **MODE** key, the balance changes the adjustment mode to a new weighing environment. This mode sets the response of the balance. This parameter is common to the "Response / Environment" function and "Condition of response". Refer to this function and "Condition of response".



PRINT

The **PRINT** key can be used to output data to a printer or personal computer if the RS-232C or current loop is installed. Please refer to section "Functions" for details of output format and setting up the balance.



Units

The most common unit of weight used around the world is grams, but there is often a need to shift to an alternative unit specific to the country where the balance is used or to select modes such as counting or percent.

The **MODE** key is used to switch between these Units. The complete weighing mode cycle is as follows (if some are missing please refer to your dealer):

If a mode or unit of weight has been turned off, the sequence will be missing that mode or unit. There are also the various Tael and Tola that can be included if necessary. (Tael is selected a unit from four units by the factory)

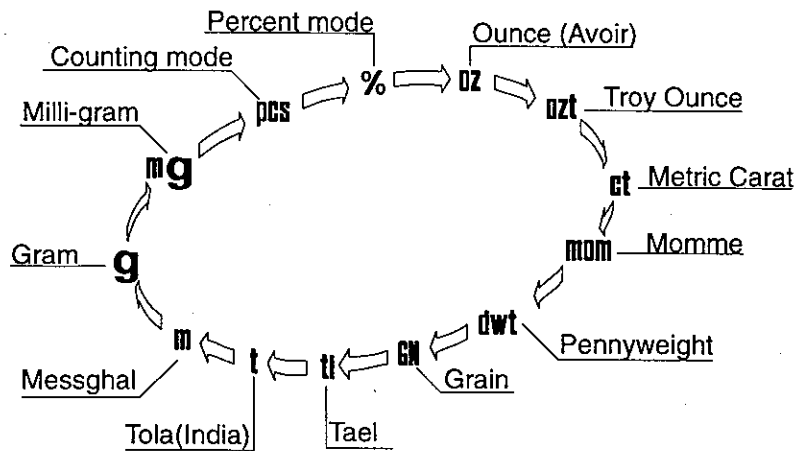

If the law in your area permits, you may use all of the units, or at this software level you can disable the weighing units you don't regularly use. Also, some dealers may initially turn OFF units which are not in regular use, but you may want to turn them back on.



Weighing Units and their Conversions

Abbrev.	Name	Conversion
mg	Milli-gram	0.001g
oz	Ounce (Avoir)	28.3495231g
ozt	Troy Ounce	31.1034768g
ct	Metric Carat	0.2g
mom	momme	3.75g
dwt	Pennyweight	1.55517384g
GN	Grain (UK)	0.06479891g
tl	Tael (HK general, Sing.)	37.7994g
tl	Tael (HK, jewelry)	37.429g
tl	Tael (Taiwan)	37.5g
tl	Tael (China)	31.25g
t	Tola (India)	11.6638038g
mes	Messghal	4.6875g



Selecting the Weighing Units

- 1** Turn off the display
- 2** Press and hold the **MODE** and press the **ON:OFF** key. The balance will display the test mode and then "Unit".
- 3** Select the modes you want active using the following keys:

MODE key to step through the modes

RANGE key to select the mode

ON:OFF key to cancel the updating new set

- 4** Press the **PRINT** key to store a new mode set selected the modes and return to normal display.

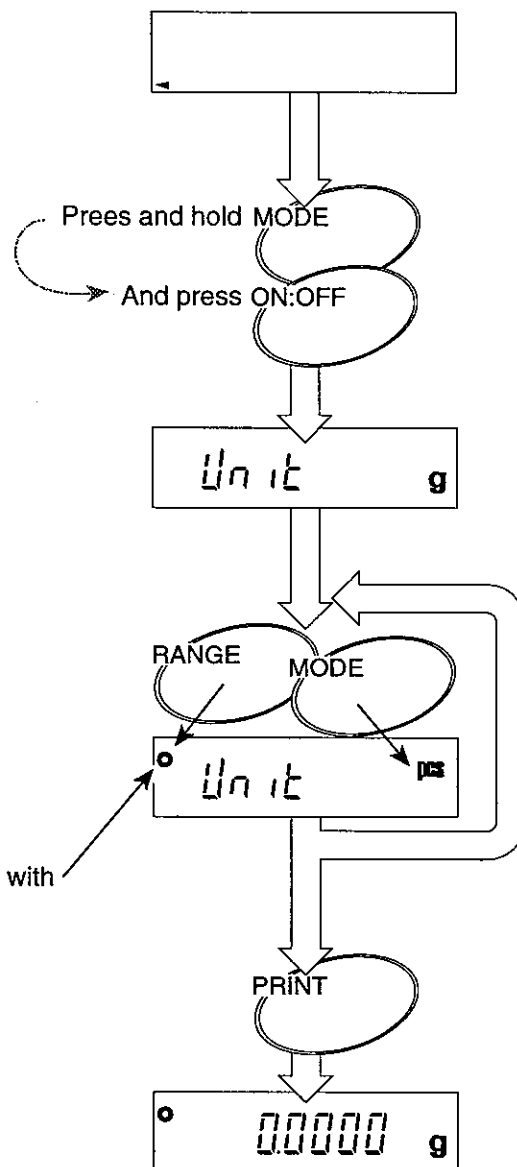



Weighing



For accurate weighing, please warm up the balance for an hour before use and try to meet "Best conditions for weighing".



Simple Weighing

- 1 Turn the display on using the **ON:OFF** key. After a moment "zero" will be displayed.

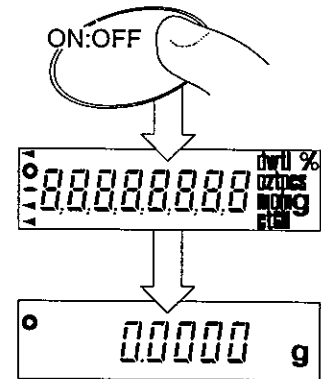

- 2 If you are using a tare container, place it on the weighing pan. The display will show the container weight.

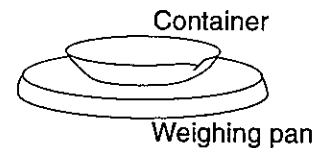

- 3 Press the **RE-ZERO** key to cancel the weight.

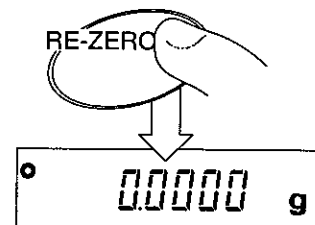

- 4 Place the object to be weighed in the container.

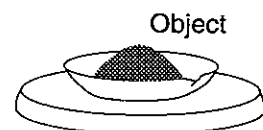

- 5 Wait for the stabilization mark to be displayed on and read the weight.

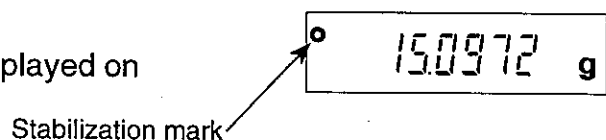

- 6 Remove the object from the pan.

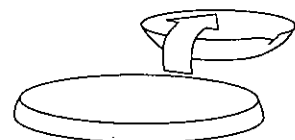

- 7 Turn the display off using the **ON:OFF** key. The display will show the stand-by indicator.

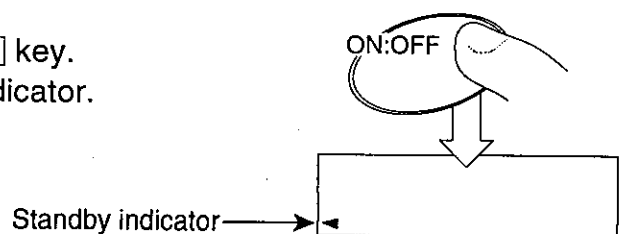

Counting Mode (pcs)

Often there is a need to be able to count small parts or pharmaceuticals. This is usually an inventory function that can be a problem due to the light weight of the individual item.

The HM balance counts by calculating the average weight of one piece-weight called the unit weight, then applying it to the total weight of what you are trying to count. A&D has added exclusive software called ACAI™ (Automatic Counting Accuracy Improvement) that constantly updates the unit weight. It is explained on page 13.

The minimum unit to be able to store it is the same as minimum figure of display. (The HM-202 can store it as an upper range value only)

This is the step by step process for using the counting function:

- 1** Select "pcs" using the **MODE** key. If the balance displays "10", proceed to the step 3. If the balance does not display "10", press the **RANGE** key and proceed to step 3.
- 2** If you want to select the quantity to be used as a sample, see page 12.
- 3** For convenience a container may be placed on the pan. Press the **RE-ZERO** key to clear any offset from zero, such as the container to hold the items to be counted.
- 4** Place the sample to be counted on the pan (This will normally be the same quantity as the count displayed).
- 5** Wait for the stabilization to come on. Press the **RANGE** key. The balance will store the sample weight. Then the balance will display the counts. (First count will be ten items)
- 6** Remove the sample and container from the pan.

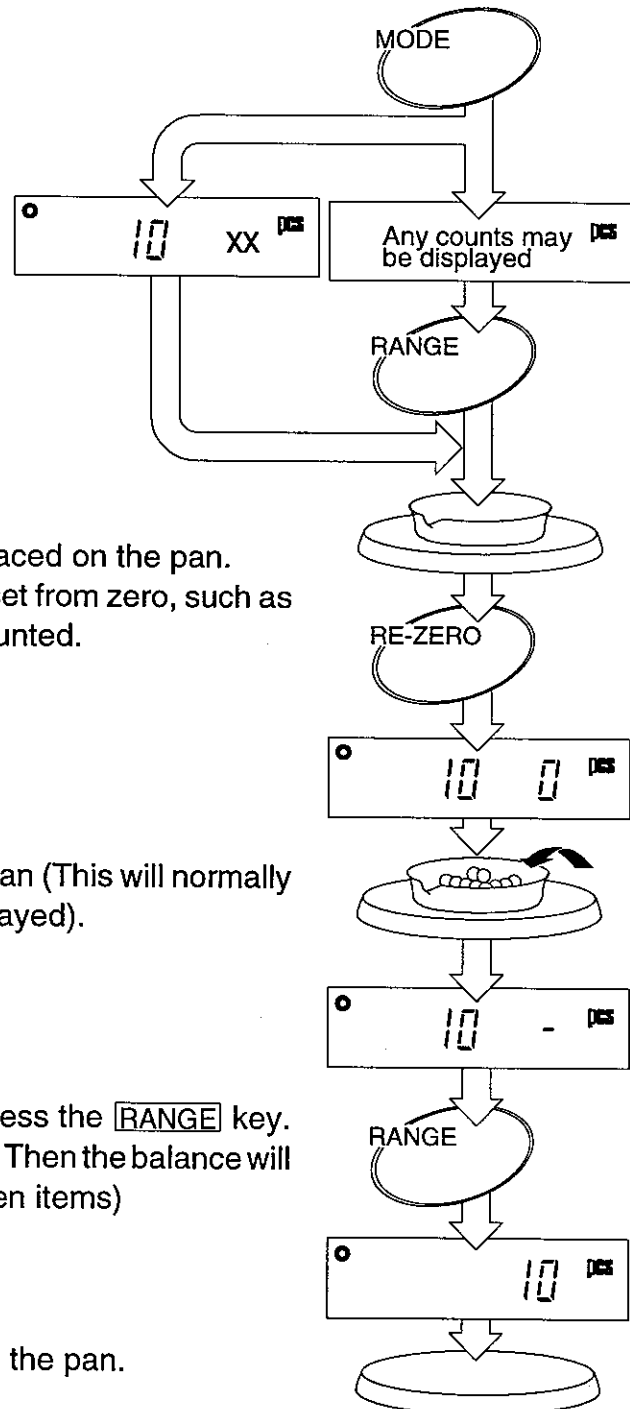

Selecting the Quantity to be Used as a Sample

You can select the quantity to be used as a sample in step 2.

- 1 Select "pcs" using the **MODE** key. If the balance displays "10", proceed to the step 2. If the balance does not display "10", press the **RANGE** key and proceed to step 2.

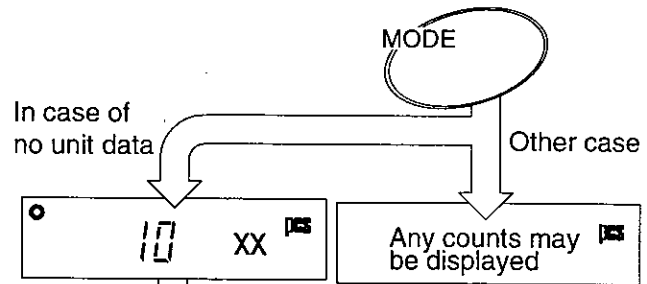

- 2 Select the number of items to be used for the sample using the **PRINT** key. This may be set to 10, 20, 30, 40, 50, 60, 70, 80, 90 or 100. (The higher the number, the better the accuracy).

- 3 Press the **RANGE** key.

- 4 For convenience a container may be placed on the pan. Press the **RE-ZERO** key to clear any offset from zero, such as the container to hold the items to be counted.

- 5 Place the sample to be counted on the pan (this will normally be the same quantity as the count displayed).

- 6 Wait for the stabilization mark to come on. Press the **RANGE** key. The balance will calculate the unit weight and store it (This value is saved, even if the balance is turned off).

Error

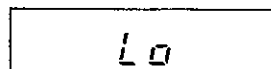

- 7 If the sample is very light, the balance may not be able to perform the counting mode.

Remove the sample and container from the pan.

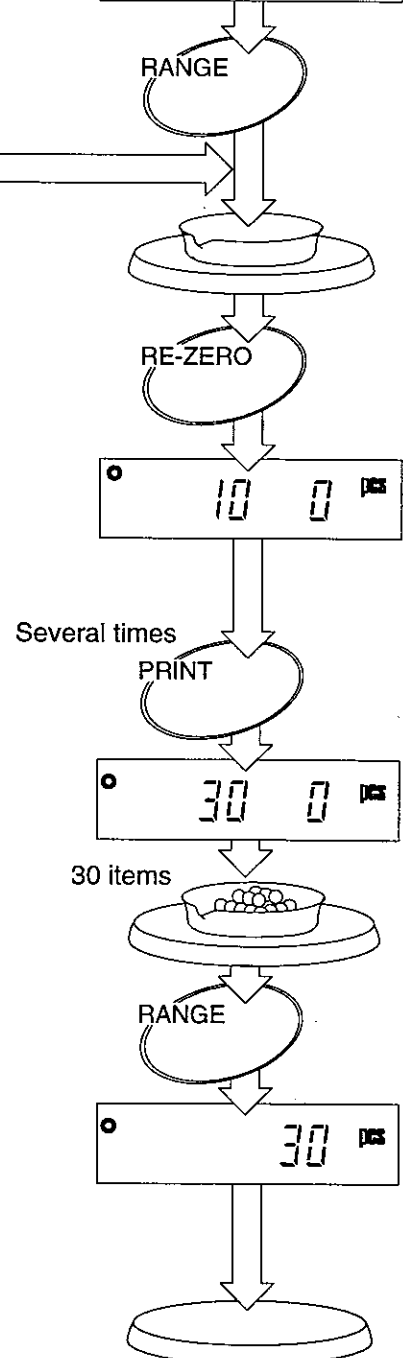

ACAI Automatic Counting Accuracy Improvement

The ACAI indicator

The ACAI™ (Automatic Counting Accuracy Improvement) function re-calculates the unit weight as more items are added, to improve the accuracy.

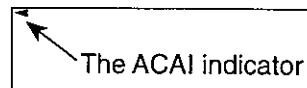

When the balance calculates the unit weight, the higher the number of items in the sample, the higher the accuracy.

Example: If you use 10 very small parts as your sample, with a unit weight of 0.1000 grams calculated by the balance. Using the ACAI feature, after 200 parts were counted, the updated unit weight was .0995 grams. This does not seem like a significant difference, but the count could have been off by 1 part at a count of 200, 2 parts at 400, etc..

$$0.1000 - 0.0995 = 0.0005g$$

$$0.0005g \times 200 \text{ parts} = 0.1000g \text{ or } 1 \text{ part.}$$

This would not be acceptable if the part is expensive. This would be totally unacceptable to a purchaser if he stopped to count the parts.

To use ACAI, Follow the steps outlined on the previous pages, then follow these steps:

- 1** Add a small number of additional parts (it is not necessary to count the added number). Then the ACAI indicator will blink several times.
- 2** The balance has updated the unit weight after the display stops blinking. Wait until the ACAI indicator turn off, then continue.
- 3** ACAI stores the corrected unit weight in memory until a new sample is established, or the process is repeated.



Please add these samples according to the table to best use the ACAI function.

Count on the weighing pan	Next total count on the weighing pan	Count on the weighing pan	Next total count on the weighing pan
10	13~26	70	73~118
20	23~47	80	83~128
30	33~65	90	93~138
40	43~81	100	103~148
50	53~95	101~	As necessary, but no less than 3 items greater than the current count.
60	63~108		



ACAI Notes

- You must use the ACAI procedure immediately after establishing the unit weight. Do not remove any of the original samples, just continue to add.
- There is no need to actually count the additional items added.
- Do not remove the sample until the ACAI procedure is completed (if you remove the sample, the balance will accept this as the maximum amount that you want the ACAI to correct for).
- The balance will store the unit weight for the next count.
- If you use "Digital Unit of Weight" the balance can not use the "ACAI" mode for counting.

Counting Mode using Digital Input of Unit Weight

If you know the unit weight of the objects to be counted, it may be entered using the keyboard or from a computer using the optional RS-232C interface. This is especially useful when inventorying a warehouse or pharmacy where many different unit weights are already known.



If you use "Digital Unit of Weight" the balance can not use the "ACAI" mode for counting.

1

Select "pcs" using the **MODE** key.

2

Press and hold the **RANGE** key to select the unit for the unit of weight. The balance will display "00".

3

Select the unit using the **MODE** key for unit weight.

4

Press the **RE-ZERO** key to input the digital unit weight. The balance will display the last unit weight or "....." if there was no unit weight in memory.

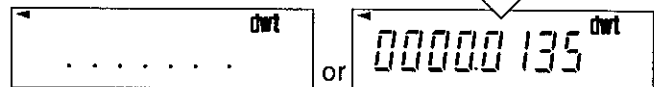

5

Press the **MODE** key. Then you can enter a new unit weight.

6

Select the digit to be changed using the **MODE** key. Press the **RE-ZERO** key to change the value of the digit selected. Continue this process until all of the digits are set correctly.

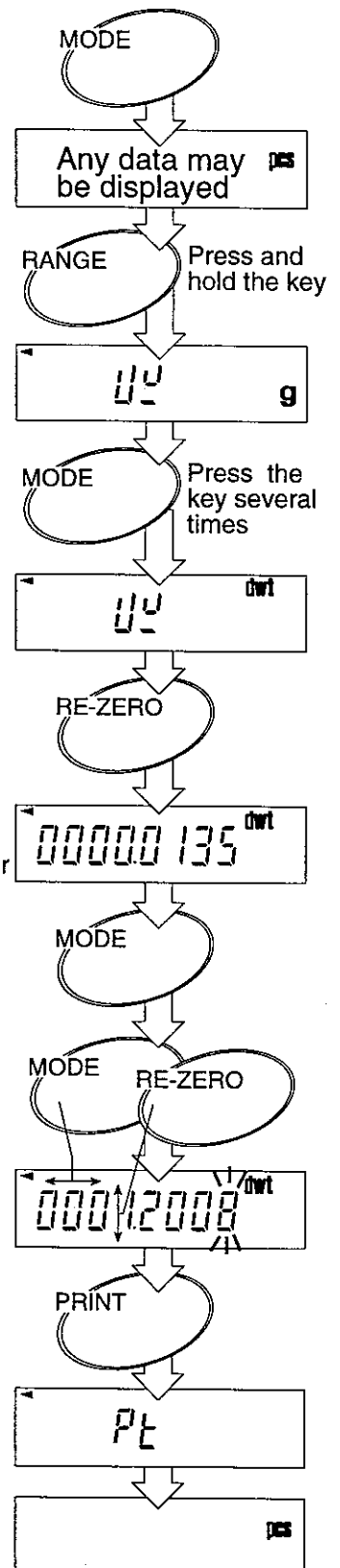

7

Press the **PRINT** key to store the new unit of weight in memory.

8

The balance will display " Pt " for several seconds, then the count will again be displayed. Continue with your counting.

Percent Mode (%)



The HM balance has a Percentage mode that allows you to establish a 100% point, and then use this to determine a percentage based on that sample. Less or greater than 100% may be displayed at 1%, 0.1% or 0.01%, dependent on the range of digits used.

The minimum unit-weight that can be stored is 10.0mg.

- 1** Select "%" using the **MODE** key. If the balance displays "100 xx", proceed to the step 3.
- 2** If you want to change the 100% weight, press the **RANGE** key to switch to the sample input mode.
- 3** Press the **RE-ZERO** key to set the zero point.
- 4** Place the item to be used as the sample on the pan.
- 5** Press the **RANGE** key. The balance will store the weight of the sample as the 100% point.
- 6** Remove the sample and place another item to be checked on the pan. Wait for the stability indicator to come on and read the percentage.

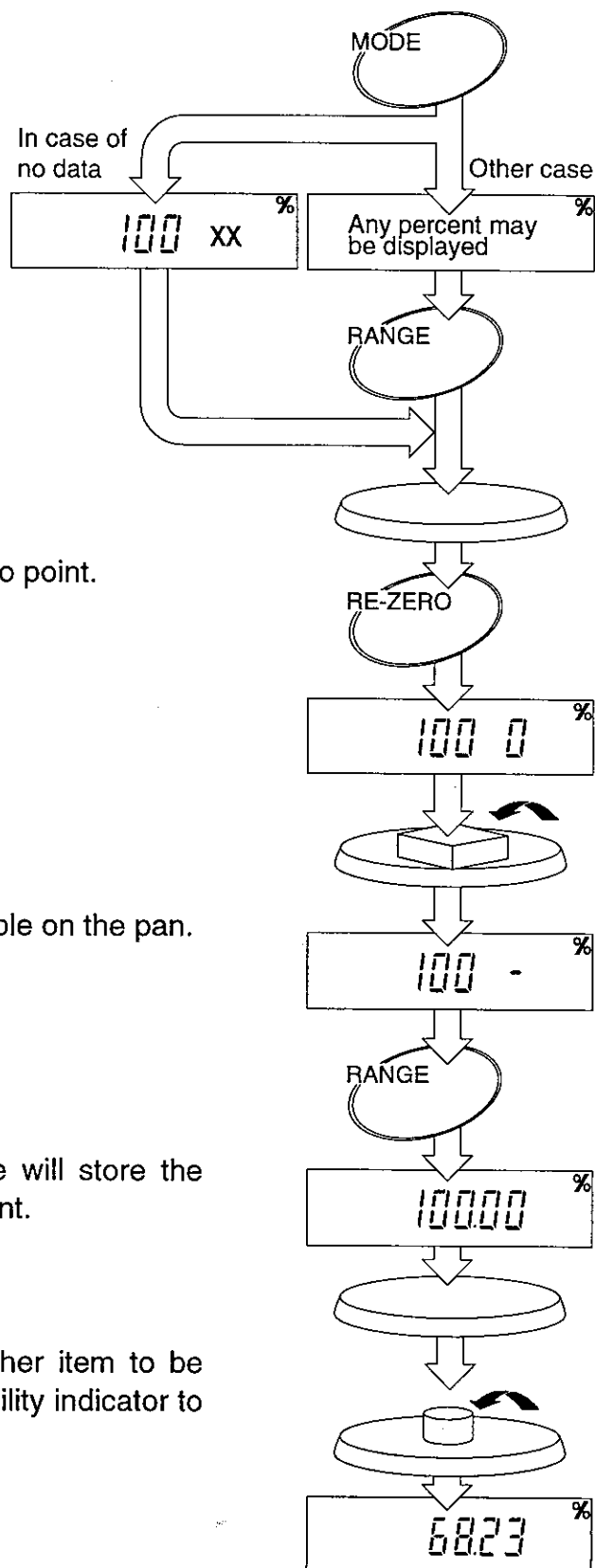

Percent Mode (%) with Digital Input of 100% Weight



The HM balance has a Percentage mode that allows you to enter the 100% weight using the keyboard or a computer (using the optional RS-232C interface) for the percentage sample.

- 1** Select "%" using the **MODE** key.
- 2** Press and hold the **RANGE** key to switch to the sample input mode. "P_" will be displayed.
- 3** If you would like to use a different weighing unit other than the one shown, Press the **MODE** key to select the unit of weight.
- 4** Press the **RE-ZERO** key to display 100% weight. If no 100% weight is stored in memory the display will be ".....".
- 5** Press the **MODE** key to enter the value setting mode.
- 6** Press the **MODE** key to select the digit to change and the **RE-ZERO** key to set the value of the digit selected.
- 7** Press the **PRINT** key to store this value.

"P_" will be display for a few seconds, then the balance weights in percentage mode.

The sample weight for the 100% point is stored in memory and will be retained if the power is turned off.

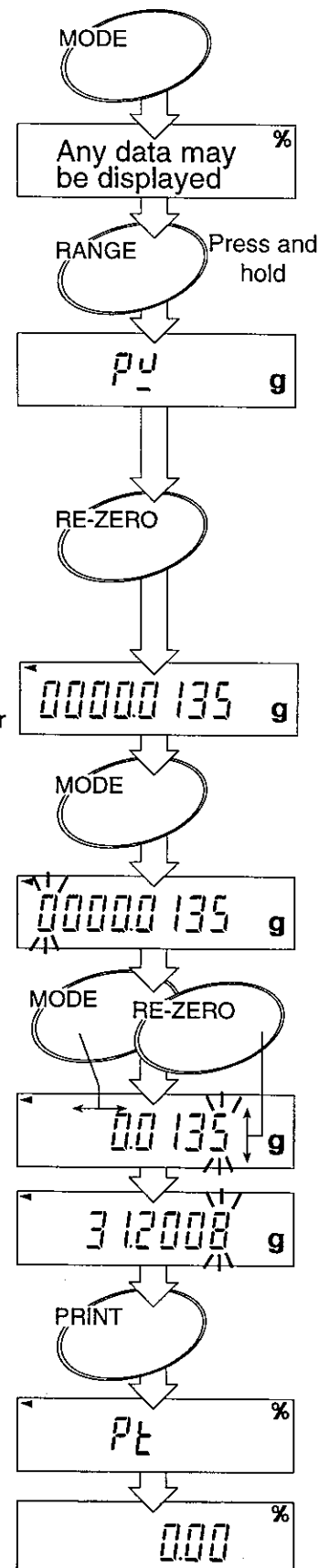



Environment Response Adjustment

The HM series has three functions to adapt the balance to environmental changes.

Condition response Use this setting when you want a reading as quickly as possible or a reading as stable as possible. This parameter is common data with the "Response /Environment" function. Refer to "Functions" and the Condition of Response procedure.

Calibration This mode allows recalibration, canceling possible weighing error due to gravity, altitude, air pressure, ambient temperature and humidity using a calibration mass. Please use a calibration mass sufficiently precise to recalibrate the smallest digit of the display.

Please calibrate the balance when you move the balance or perform the periodical maintenance. Refer to "Calibration".

Function The HM series has a number of internal software parameters so that you are able to select the best weighing features for your needs. Refer to "Function".



Conditions of Response



In this procedure, If you do not complete the next steps within five seconds, the balance will return to the weighing mode without saving the new parameter.

Conditions Determining Response Rate

Parameter setting		
Cond	0	better weighing conditions faster weighing response
	1	
	*2	worse weighing conditions slower weighing response
	3	
	4	

* factory setting

1 Press and hold the **MODE** key. The balance will change to the "Condition of response" mode and the display will show the "Cond".

2 Press the **RE-ZERO** key several times until the parameter you want is displayed.

This mark displays with a memorized parameter

3 Press the **PRINT** key. The balance will change to weighing mode, saving the new parameter. This is stored in the balance memory, even if the AC adaptor or optional battery is removed from the balance.

ex. most stable parameter

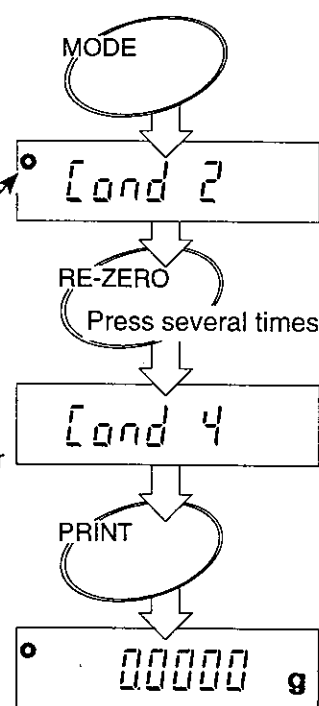

Calibration



Prevent vibration, drafts, and ambient temperature changes from affecting the balance during calibration.

- Please set the parameter of Function [- 3] before you perform the calibration.
- Please set the parameter of Function [- 4] in F₀ before you perform the calibration, if you use serial interface option OP-03 or OP-05.
- To get the output for Good Laboratory Practice (GLP), set the parameter of Function [- 3] and [- 4] before you perform the calibration.
Refer to Functions and Option Manual.
- Use a very precise calibration mass. The accuracy of your balance is decided by this calibration mass.
- Please perform the calibration when you move the balance or before use.
And Please check the accuracy using "Calibration check" periodically.
- Please select your calibration mass from following table. The calibration mass is set to the value in bold type when the balance enters the calibration mode.

Model - Calibration mass

HM-120	50g	100g
HM-200	100g	200g
HM-300		200g 300g
HM-202	100g	200g

Displays and Canceling Calibration

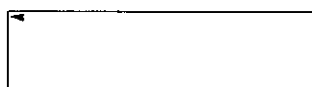

This mark means "the balance is measuring calibration data". Do not allow vibration or drafts to affect the balance while this mark is displayed.

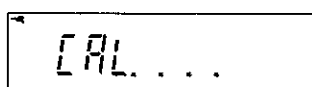

This sign means status of performing the calibration.

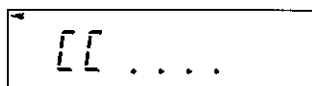

This sign means status of performing the verification calibration mode.

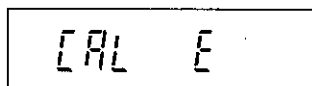

"CAL E" will be displayed if the calibration mass is too heavy.

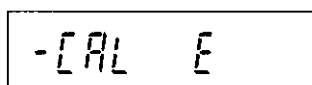

"-CAL E" will be displayed if the calibration mass is too light.

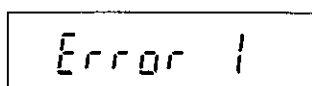

Warning of instability due to vibration or drafts. Please check ambient conditions. See also the conditions. If you choose eg. Cond 3 or 4 you are likely to have a more stable reading.



The **ON:OFF** key cancels the execution of calibration without saving new data and the display turns off.

One Touch Calibration

The simplest way to perform the calibration is shown below. This assumes that you do not want to enter a different value for the calibration mass, that parameter "[-3, CAL 1 or 2]" is set to "Permission of key operation". This illustration is for model HM-200.

- 1** Warm up the balance for at least one hour with nothing on the weighing pan. Turn the display on.
- 2** Press and hold the **RE-ZERO** key to enter calibration mode.
- 3** Release the **RE-ZERO** key at the time when the balance is flashing "CAL". (The balance displays some modes alternatively.)
- 4** The balance informs you of entering the Calibration Mode.
- 5** Ready for zero-point-calibration.
- 6** Measuring zero-point data for zero-point-calibration.
- 7** Ready for full-scale-calibration.
- 8** Measuring full-scale data for full-scale-calibration.
- 9** The balance informs you of finishing with the calibration. (It is able to output the calibration report, if you need.)
- 10** The balance returns to the weighing mode automatically.

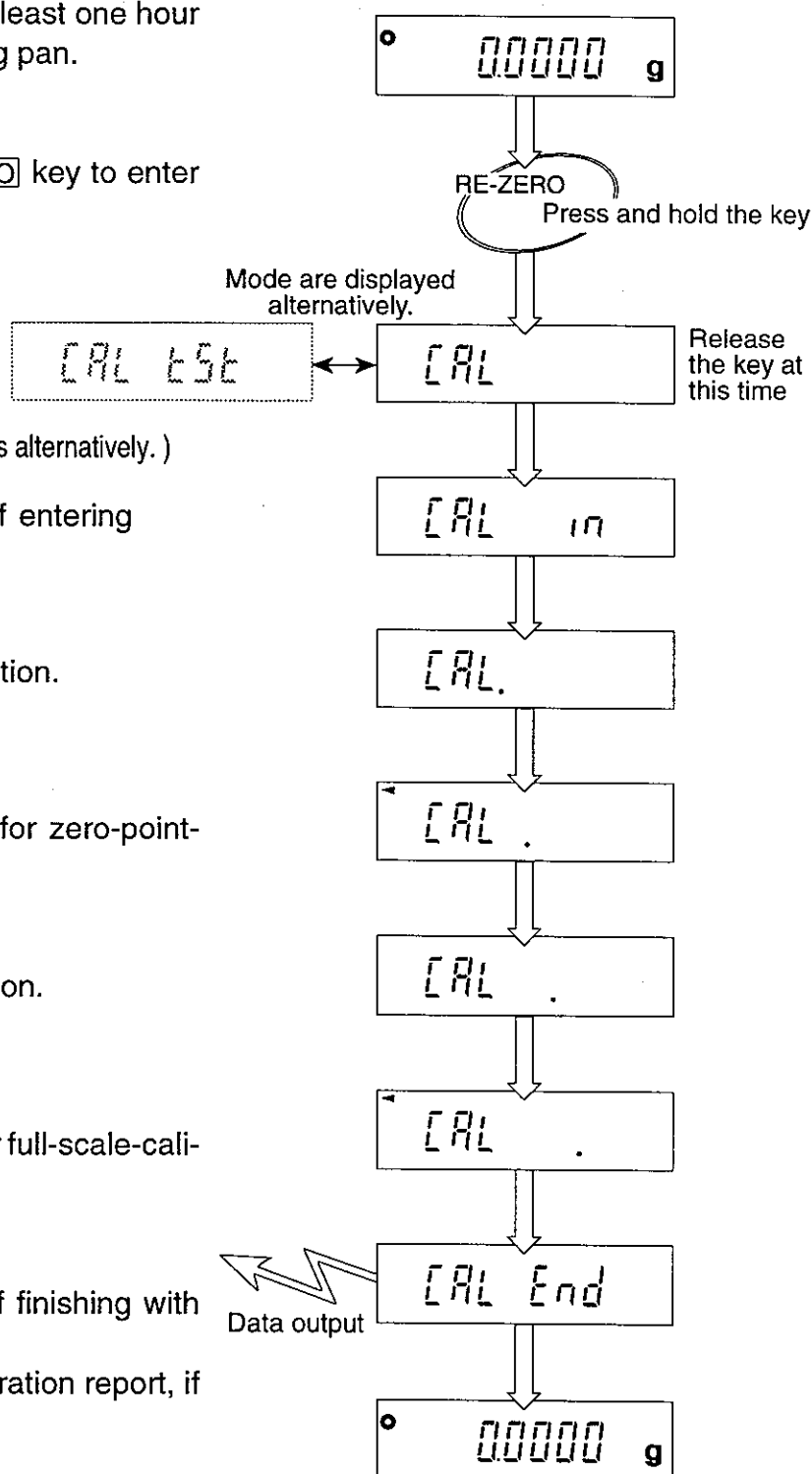

One Touch Calibration Test

This procedure performs verifying calibration using the internal calibration mass and the balance displays the data of measuring the zero-point and the calibration mass. The balance can output this data. This assumes that parameter "[-3, CAL 1 or 2]" is set to "Permission of key operation". This illustration is for model HM-200.

1 Warm up the balance for at least one hour with nothing on the weighing pan. Turn the display on.

2 Press and hold the **RE-ZERO** key to enter calibration verification mode.

3 Release the **RE-ZERO** key when the balance flashes "CAL EST".
(The balance displays some modes alternatively.)

4 The balance informs you of entering Verifying Calibration Mode.

5 Ready for zero-point-calibration.

6 Measuring zero-point data.

7 The balance displays measured data.

8 Ready for full-scale-calibration.

9 Measuring full-scale data.

10 The balance displays measured data (and outputs the data, if you use the serial interface).

11 The balance informs you of finishing with the verifying calibration.
(It is able to output the calibration report, if you need.)

12 The balance returns to the weighing mode automatically.

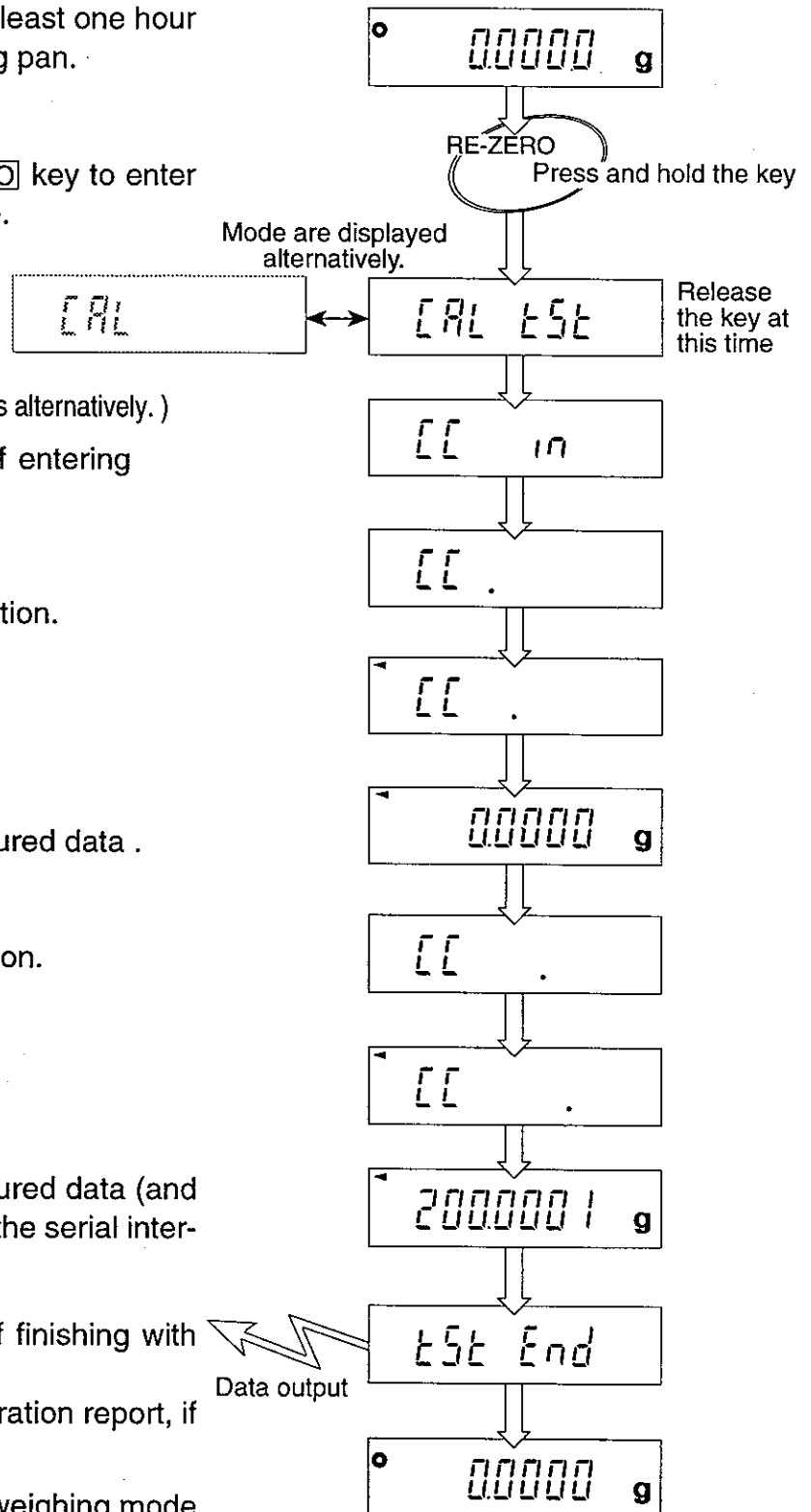

Manual Calibration

This procedure is used to perform manual calibration using your own calibration mass. This assumes that parameter "[- 3, [AL 1 or 2" is set to "Permission of key operation". This illustration is for model HM-200.

- 1** Warm up the balance for at least one hour with nothing on the weighing pan.
Turn the display on.
- 2** Press and hold the **[RE-ZERO]** key to enter the calibration mode.
- 3** Release the **[RE-ZERO]** key when the balance is flashing "[AL".
(The balance displays some modes alternatively.)
- 4** The balance informs you of entering Calibration Mode by displaying "[AL in".
Press the **[PRINT]** key immediately.
Then the balance will enter the Manual Calibration Mode.
- 5**
 - If you do not want to change the calibration mass weight, proceed to step 8.
 - If you want to change the calibration mass value, press the **[MODE]** key.
- 6** Enter the calibration mass value using the following keys.
 - [MODE]** key Used to move digit to enter a number.
 - [RE-ZERO]** key Used to change a number.
- 7** Press the **[PRINT]** key. The balance stores the new calibration mass value.
- 8** In case of storing a new parameter again, proceed to step 5.
In other cases, proceed to step 9.
- 9** Verify that there is nothing on the weighing pan.
- 10** Press the **[RE-ZERO]** key.
The balance measures the zero-point.

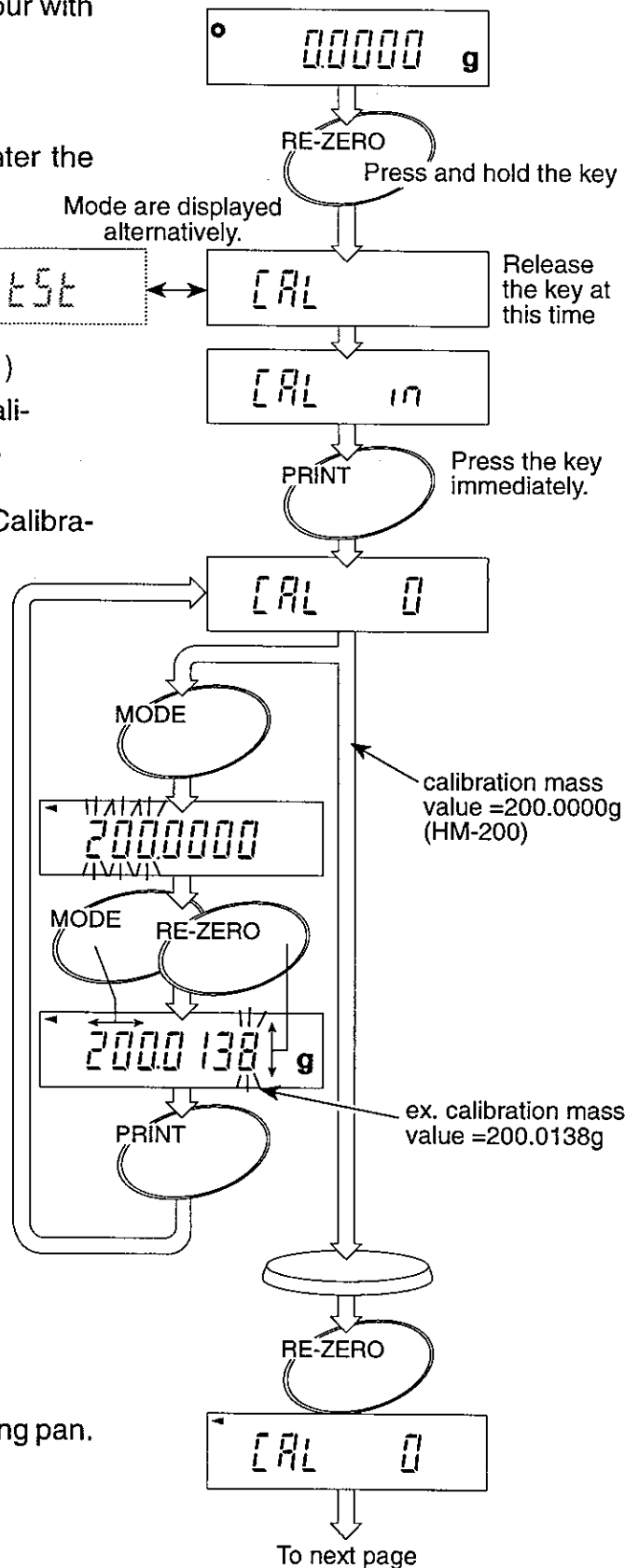

11 *CAL 200* will be displayed.
Place the calibration mass on the pan.
(If you want to perform zero-point-calibration only,
press the **RE-ZERO** key without a calibration mass
and proceed step 13.)

12 The balance measures the calibration mass
value.

13 The manual calibration is finished.
(The calibration report will be output, if you
have selected that function and have OP-03 or
OP-05 installed.)

14 Remove the calibration mass from the pan.
The balance will return to the normal weighing
mode automatically.

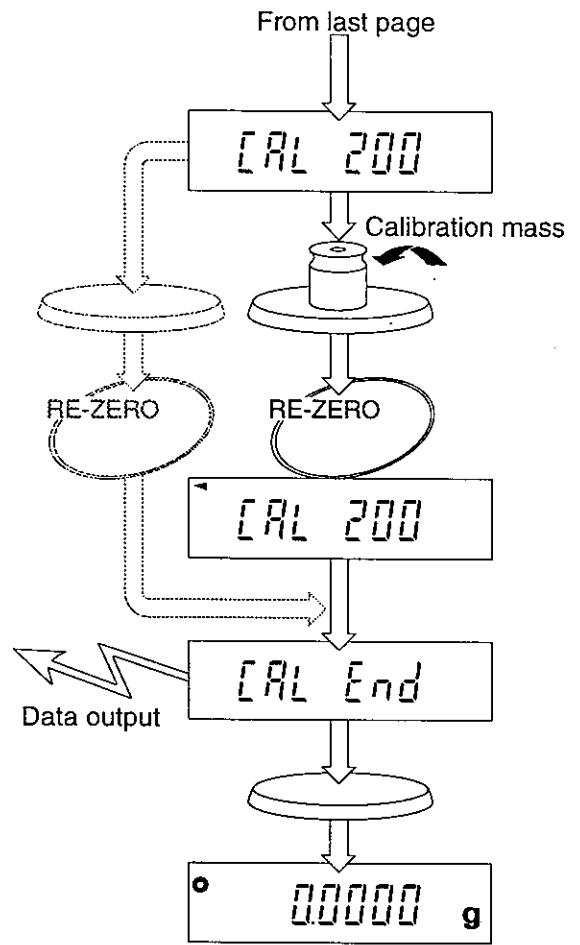

Manual Calibration Test

This procedure performs calibration verification using your own target mass. The balance can output this data. This assumes that parameter "[CAL 1 or 2]" is set to "Permission of key operation". This illustration is for model HM-200.

- 1** Warm up the balance for at least one hour with nothing on the weighing pan. Turn the display on.
- 2** Press and hold the **[RE-ZERO]** key to enter the calibration mode.
- 3** Release the **[RE-ZERO]** key when the balance flashes "**[CAL EST]**".
(The balance displays some modes alternatively.)
- 4** The balance informs you of entering the Calibration Check Mode by displaying "**[CAL in]**". Press the **[PRINT]** key immediately. The balance enters the Manual Calibration Check Mode.
- 5**
 - If you do not want to change the target mass weight, proceed to step 8.
 - If you want to change the target mass value, press the **[MODE]** key.
- 6** Enter the target mass value using the following keys.
 - [MODE]** key Used to move digit to enter a number.
 - [RE-ZERO]** key Used to change a number.
- 7** Press the **[PRINT]** key. The balance registers the new target mass value.
- 8** In case of storing a new parameter again, proceed to step 5.
In other case, proceed to step 9.
- 9** Verify that there is nothing on the weighing pan.
- 10** Press the **[RE-ZERO]** key. The balance measures the zero-point.

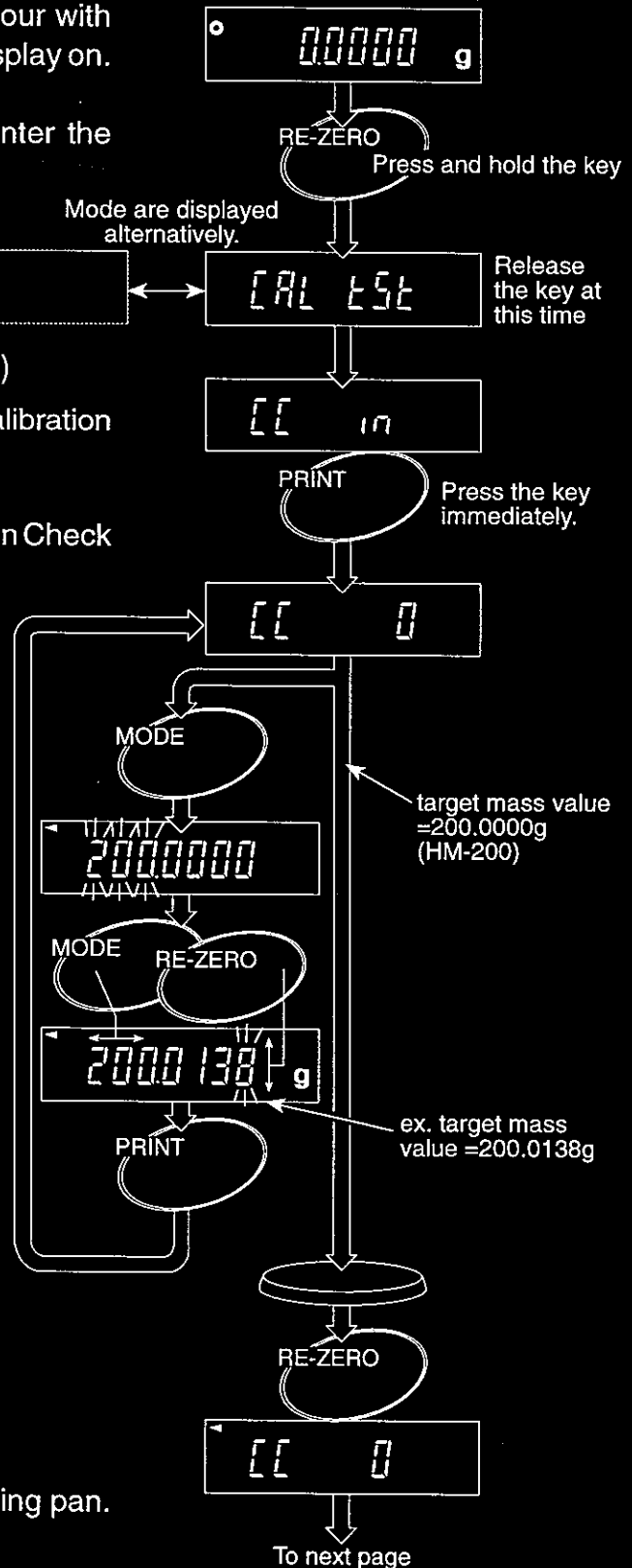

11 The balance displays the measured zero-point data.

12 `[[200` will be displayed.
Place the target mass on the pan.

13 Press the `RE-ZERO` key.
The balance measures the target mass value.

14 The balance displays the measured target mass value.

15 The manual calibration check is finished.
(If you use the serial interface, the balance transmits the calibration report)

16 Remove the target mass from the pan.
The balance will return to the normal weighing mode automatically.

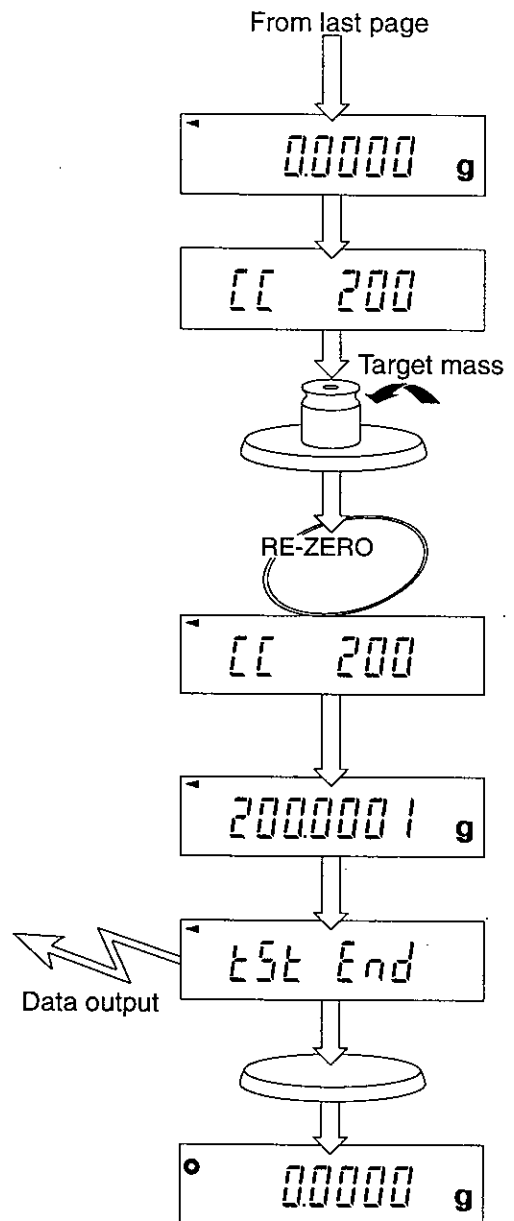



Correcting the Internal Calibration Mass Value

(For software versions after 1.10)

The balance can correct the value of the internal calibration mass within ± 1.5 mg range. This mass value is set at the factory, but may be reset if necessary.

HM-120 — 100.0000g

HM-200,300 and 202 — 200.0000g

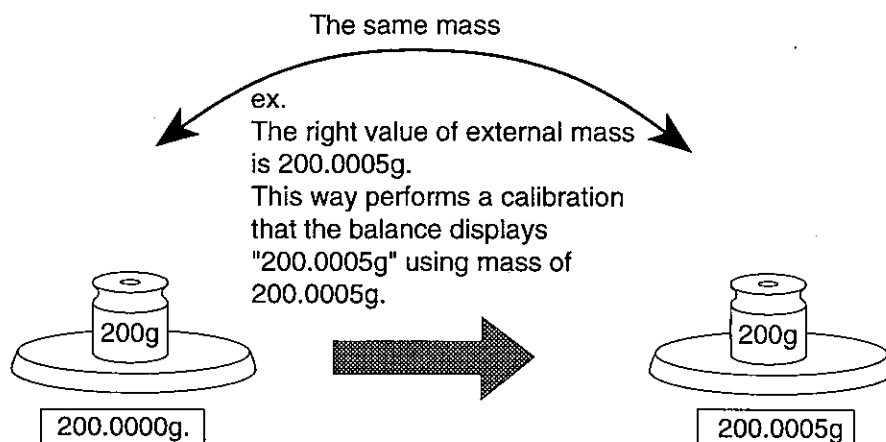

In case of HM-200M

Procedure for correcting the internal calibration mass

- 1 Press and hold the **RE-ZERO** key.
Release the **RE-ZERO** key when the balance displays **CAL**.

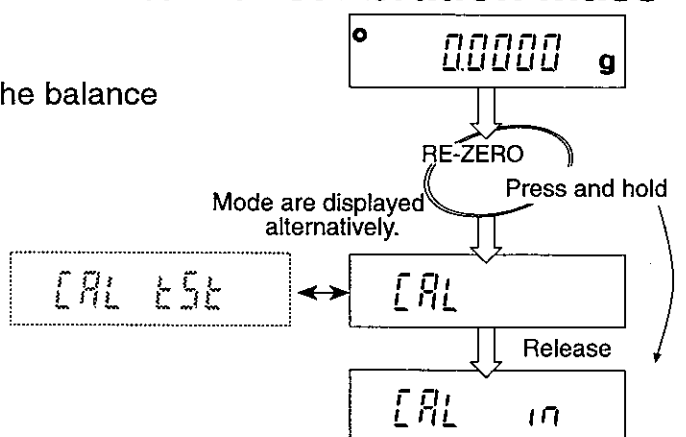

- 2 Press the **MODE** key immediately when the balance displays **CAL in**.

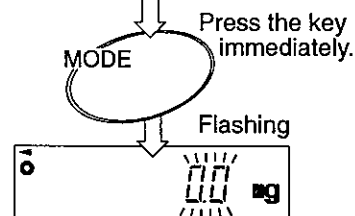

- 3 Use keys as follows:
RE-ZERO key to select the value of mass.
(-1.5mg~1.5mg)

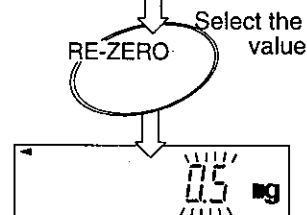

PRINT key to enter the value of mass.

(The "O" mark is displayed when the balance has stored the value)

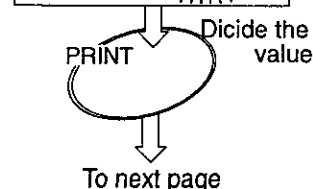

- 4** This procedure is to calibrate the balance using internal calibration mass.

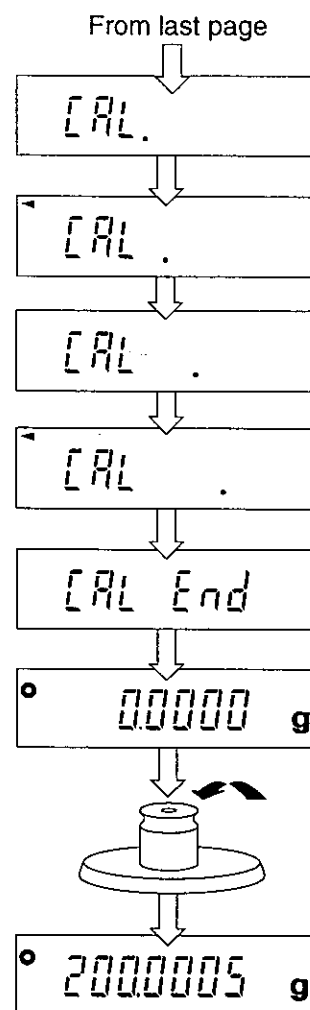

- 5** Confirm the weighing value using an external mass.



Calibration errors

The balance informs of a zero-point error, if or is displayed when pressing the **ON:OFF** key. The way of correcting the condition is to perform one touch calibration (Pg20) or zero-point calibration (Pg22).



Functions



Your HM series balance has a number of internal software parameters that enable you to select the best weighing features for your needs. These settings control how you want the balance to respond to its environment, various commands, operations and options. An overall parameters table is shown below.

All of the parameters have initial settings from the factory, or possibly from your dealer. You may easily change these settings as you need them, or conditions vary.

These settings are stored in the balance until the next change even without power applied. The section, C-parameters keys and displays, explains how to change the parameter. The individual settings for each group are detailed in C-parameters settings.

Group Number		Item and Item Number						
	Group	0	1	2	3	4	5	6
0	[C-0] Environment	Stb-b Stability band	Cond Resp. / Environ.	trc Zero tracking	You can select group C-4 and C-5 if your balance has option 03 or 05 installed			
1	[C-1] Display	SPEED Refresh rate	Po int Decimal point	P-on Auto start function				
2	[C-2] Auto re-zero	Ar-0 Auto re-zero on/off	Ar-b Auto re-zero band	Ar-t Detection time				
3	[C-3] Calibration	CAL Calibration inhibit						
4	[C-4] Data out	Pr int Data out mode	AP-P Auto print polarity	AP-b Auto print band	PAUSE Data pause	At-F Auto feed	Ar-d Zero after data out	info Cal verification
5	[C-5] Serial interface	bPS Baud rate	bt-Pr Length, Parity bit	[C-LF] Terminator	tYPE Data format	t-UP Receive time	E-Cod Error code	[C-S] CTS control
6	[C-6]	Response/environment is common data with the condition of response accessible using the keyboard. If a value is set in the C parameters, it will be changed if new conditions of response are set.						
7	[C-7]							
8	[C-8]							
9	[C-9] Parameter control	Pn ID protect	PF Parameter protect					

- If you install serial interface OP-03, OP-05 or OP-06 in the balance, you can select and change the parameter **[C-4]** and **[C-5]**.
- you can not select the parameter **[C-6]** and **[C-7]**.



C-parameter Keys and Displays

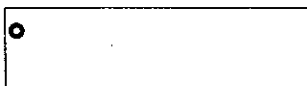

This mark appears when a selected parameter is displayed.



The **[MODE]** key is used to select the group of C-parameters.



The **[RANGE]** key is used to select the item from the group selected by the **[MODE]** key.

RE-ZERO

The **RE-ZERO** key is used to select a parameter for the item selected by the **MODE** and **RANGE** keys.

PRINT

The **PRINT** key is used to save the new C-parameter settings and to exit to the weighing mode.

ON:OFF

The **ON:OFF** key cancels the new C-parameter settings and turns the display off.

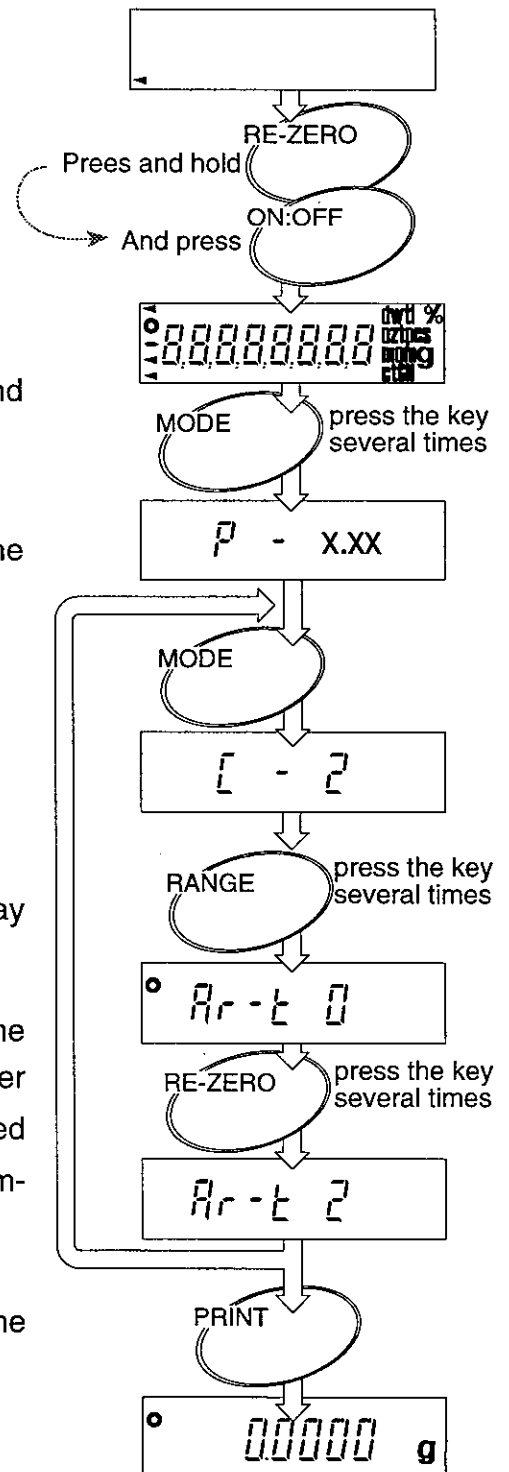

Internal Parameter Setting

- 1** Turn the display off.
- 2** Press and hold the **RE-ZERO** key and press the **ON:OFF** key. Release both keys.
- 3** Press the **MODE** key.
The balance displays the software version (x.xx) and enters to C-parameters settings.
- 4** Press the **MODE** key (several times), To display the parameter " $\tau - 2$ ".
- 5** Press the **RANGE** key (several times), To display the parameter " $Rr - t$ ".
- 6** Press the **RE-ZERO** key (several times), To display the parameter " 2 ".
- 7** If you want to enter parameters in other item, use the following keys. **MODE** key to select the parameter group. **RANGE** key to select the item of the selected parameter group. **RE-ZERO** key to select the parameter of the selected items.
- 8** Store the C-parameter set using the **PRINT** key. The balance will return to the normal weighing mode.



C-Parameter Settings

[- 0] Environment: The settings adjust the balance to your environment.

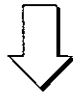
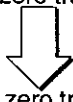
		 The Stability indicator lights when the display fluctuation is within the range set below	
Stb-b Stability band width	0	Stable when within ± 1 digit per second.	
	*1	Stable when within ± 2 digits per second.	
	2	Stable when within ± 3 digits per second.	
Cond Response / Environment	0	Better weighing conditions faster weighing response   Worse weighing conditions slower weighing response	
	1		
	*2		
	3		
	4		
trc Zero tracking	0	Zero tracking off	The balance tracks zero-drift caused by change of temperature, humidity, air pressure, etc., and stabilizes the ZERO point. Display continues to ZERO if the drift is less than 1 digit per average. If weighing very light samples, select a lower number (weak tracking).
	1	Weak zero tracking	
	*2		
	3		
	4		



* factory setting.

[- 1] Display Update, Decimal Point and Auto Start

SPEED Display update rate	*0	Display is refreshed at normal speed.	
	1	Display is refreshed at high speed.	
Point Decimal point display	*0	Point (.)	
	1	Comma (,)	
P-on Auto start function	*0	No auto start	Chose whether the display is to come on automatically without using the ON:OFF key when power is supplied.
	1	Auto start	

* factory setting

[- 2] Auto Re-ZERO Function

Ar-0 Auto Re-Zero function when near Zero	*0	Auto Re-ZERO off	
	1	Auto Re-ZERO on •Auto Re-ZERO occurs when display is \pm 'Ar-b' digits for the time 'Ar-t'	
Ar-b Auto re-zero band	*0	Zero when within ± 5 digits of the zero-point.	slow Re-ZERO  fast Re-ZERO
	1	Zero when within ± 50 digits of the zero-point.	
	2	Zero when within ± 500 digits of the zero-point.	
Ar-t Time for auto zero determination	*0	Re-ZERO when near zero for more than a half second.	fast Re-ZERO  slow Re-ZERO
	1	Re-ZERO when near zero for more than 1 second.	
	2	Re-ZERO when near zero for more than 2 seconds.	
	3	Re-ZERO when near zero for more than 4 seconds.	

* factory setting

[- 3] Keys that can be used for calibration.

[RL] Calibration keys accepted	0	Keyboard and EXT. switch can not be used.
	1	Keyboard can be used, EXT. switch can not be used.
	*2	Keyboard and EXT. switch can be used.

* factory setting

[- 4], **[- 5]**: refer to the instructions for these separately available options.

[- 6], **[- 7]** and **[- 8]**: Not used

[- 9]

C-parameter control

Pn ID protect	parameter	Parameter definition and use. Determines whether a change is permitted to the ID number
	*0	Permits a change to the ID number
	1	Inhibits a change to the ID number
PF Parameter protect	parameter	Parameter definition and use.
	*0	Permits a change to the C-parameters
	1	Inhibits a change to the C-parameters.
	2	C-parameters are changed to the original factory settings.

* factory setting



Miscellaneous



Digital Tare

Setting Digital Tare



Instead of placing a container on the balance and pressing the **RE-ZERO** key, you can enter the weight of the container via this Digital Tare. The Digital Tare range is from zero to maximum capacity.



If you press the **RE-ZERO** key after completion of this procedure, the balance will store the value of the weight on the pan into **Pt**. Digital tare can not store a value in the counting mode or percent mode.

- 1** Turn the display on.
- 2** Press and hold the **RANGE** key until the balance displays **Pt**. (Preset Tare)
- 3** Press the **RE-ZERO** key. The value of digital tare will be displayed. If you want to change the value, press the **MODE** key.
- 4** Set the digital tare that you want using following keys.



The **MODE** key is used to select the figure to be changed.

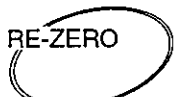

The **RE-ZERO** key is used to change the number that is displayed.



The **PRINT** key saves the new Digital Tare value and returns to the weighing mode.



The **ON:OFF** key turns the display off without saving the new Digital Tare.

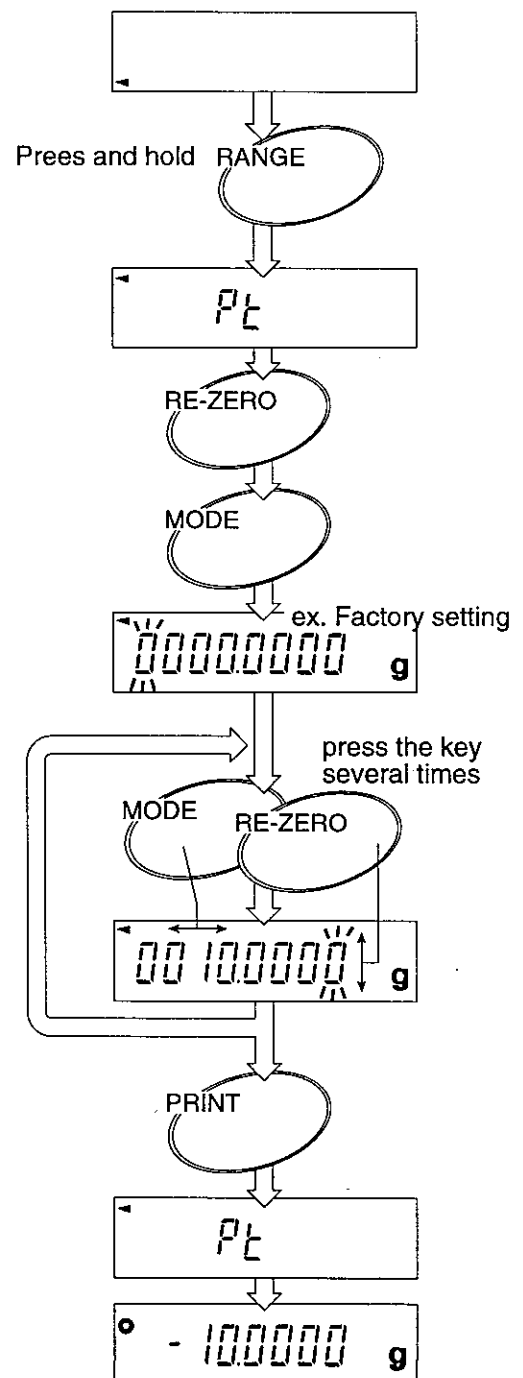

The ID Number

- Option 03 or 05 is necessary to output the balance data using the ID number.
- The data can be transmitted to an AD-8121 printer or a computer using option 03 or 05.
- The ID number is used to identify the balance when using Good Laboratory Practice (GLP).
- Verifying the calibration executes using the ID number and weighing data after the calibration. The AD-8121 printer will add the date and time.

Setting the ID number

The ID number is saved in the balance memory without the AC adaptor or optional battery connected and is effective until the next change. The ID number is eight characters.

! If you do not complete steps 2 and 3 within five seconds, the balance returns to the weighing mode without saving the new ID number.

- 1** Set the parameter $[-g, P_n]$ to permit a change of ID number. Turn the display off.
- 2** Press and hold the **RANGE** key and press the **ON:OFF** key.
- 3** The ID number is displayed. Press the **MODE** key.
- 4** Set your ID number using following keys.

RANGE

The **RANGE** key switches between numbers and letters.

RE-ZERO

The **RE-ZERO** key is used to change the character that is displayed. You can select following characters.

0-9, -, (space mark), and A-Z.

Refer to the 'Display Character Set' at the bottom of this page.

MODE

The **MODE** key is used to shift the character that is displayed.

- 5** Press the **PRINT** key to store the new ID number and return to the weighing mode.

If you do not want to enter a new ID number, press the **ON:OFF** key. This turns the display off without saving the new ID number.

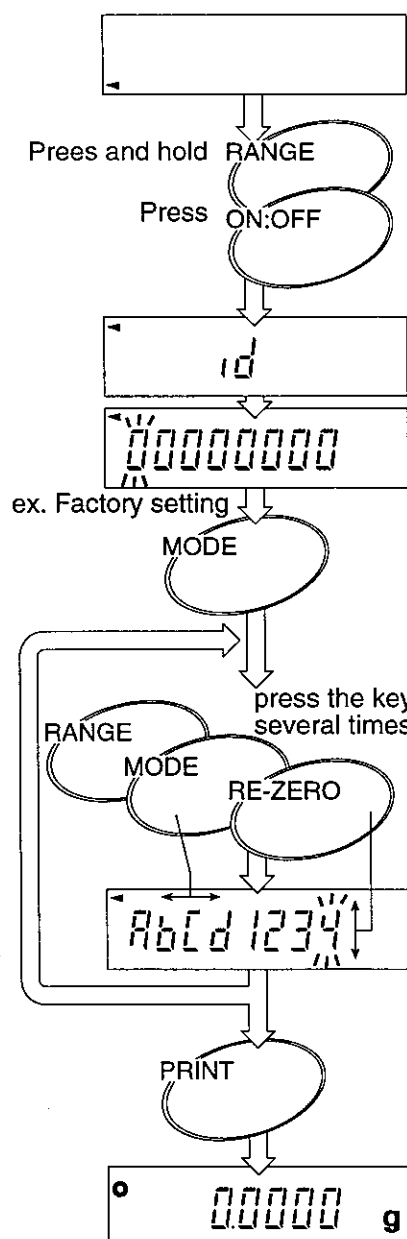

Display Character Set:

A	B	C	D	E	F	G	H	I	J	K	L	M	N	O	P	Q	R	S	T	U	V	W	X	Y	Z
R	b	[d	E	F	G	H	i	j	k	l	m	n	o	p	q	r	s	t	u	v	w	x	y	z
1	2	3	4	5	6	7	8	9	0	-	(Space)														
1	2	3	4	5	6	7	8	9	0	-															

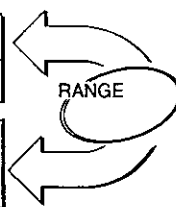

External Key Connector

An external connector plug is supplied, to enable remote control of the balance. When this plug is connected, RE-ZERO and PRINT instructions can be sent to the balance. Refer to the diagram below. You must connect the GND line to the PRINT or RE-ZERO line for at least 100ms.

In the following example, the Print switch is turned on.

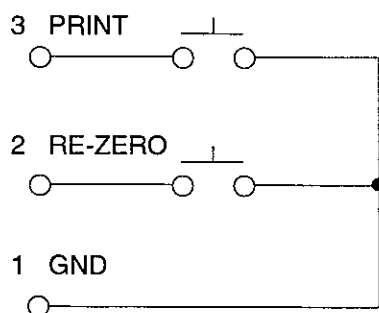
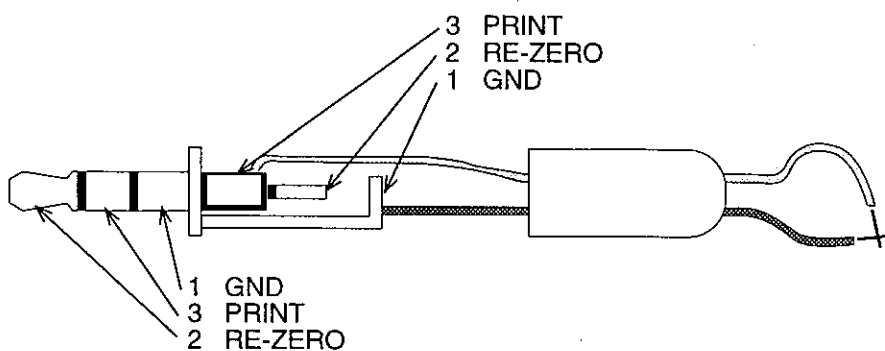

Part name: AX-T-314A-S

Underhook Weighing

The HM series balances are equipped with a standard built-in underhook. This makes density determination a relatively simple matter. Also use the underhook to weigh magnetic material.

- 1** You can find the underhook behind the plastic plug on the under-side of your balance.
- 2** Place the balance on a weighing table with a hole cut in it or place it on a firm metal stand designed for underhook weighing.
- 3** Hang a light-weight weighing harness from the underhook or thread a strand of thin string /wire through it.
- 4** For best results recalibrate the balance with the harness in place.

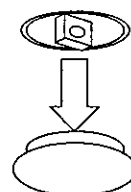
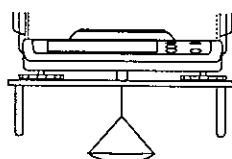

An Example of Underhook Weighing

- 1** Press the **RE-ZERO** key to zero the display.
- 2** Place the material on the pan.
Find the weight A of the material in air. $A = 10.0000\text{g}$
- 3** Press the **RE-ZERO** key.
- 4** Lower the material into water at $10\text{ }^\circ\text{C}$.
Find the weight B of the material in water. $B = 0.4666\text{g}$
- 5** Find a water density C from following table. $C = 0.99970\text{g/cm}^3$

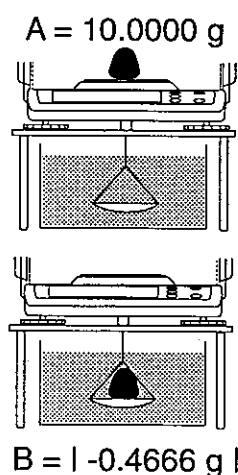

0°	0.99984 g/cm ³	
4	0.99997	
10	0.99970	
15	0.99910	
20	0.99820	
25	0.99704	
30	0.99565	Reference

$$\text{Volume} = \frac{0.4666\text{ g}}{0.99970\text{ g/cm}^3} = 0.4667\text{ cm}^3$$

$$\text{Density} = \frac{10.0000\text{ g}}{0.4667\text{ cm}^3} \approx 21.4\text{ g/cm}^3$$

- 6** The density is 21.4 g/cm^3 . This material is most likely platinum.



Specifications



Specifications

Model		HM-120	HM-200	HM-300	HM202
Weighing Capacity	g	120	210	310	210/ 42
Min. weighing display	mg	0.1			0.1/ 0.01
Min. unit weighing	mg	0.1			
Min. 100% weighing	mg	10.0			
Repeatability (Standard deviation)	mg	0.1		0.2	0.1/ 0.02
Linearity	mg	±0.2			±0.2/ 0.03
Sensitivity drift	ppm/°C	±2 (Temperature range of Sensitivity drift is 10°C ~ 30°C)			
Stabilization Time	sec.	3.0		3.5	3.5/8.0
Pan size	mm	90			80
Calibration mass (External mass)	g	50			
		100	100		100
			200	200	200
				300	
Net weight (approx.)	kg	8.5	8.2		
Operating temperature		5°C ~ 40°C (32°F ~ 104°F), RH < 85%, do not allow condensation			
Power supply		AC adaptor Please check that the adaptor type is correct for your line voltage. [factory preset]), 11VA approximately			
External dimensions		429(D) × 217(W) × 316(H)			



External Dimensions

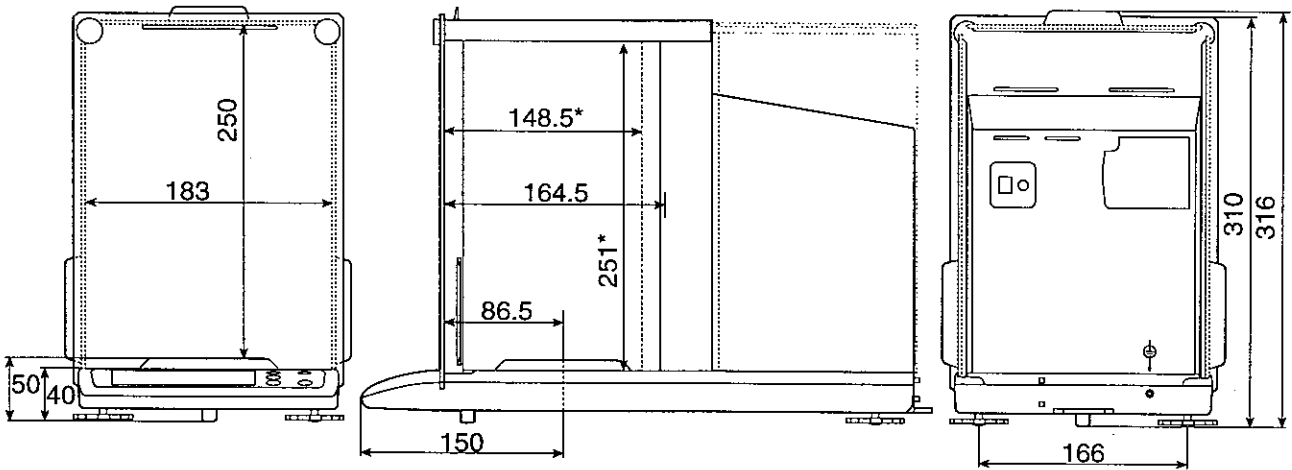
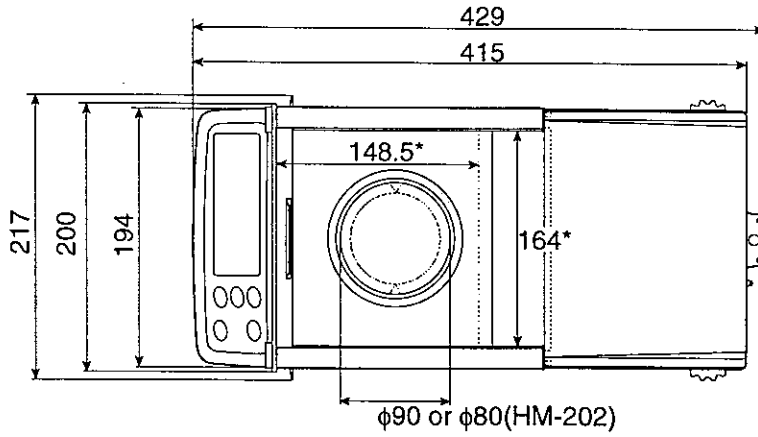

* : Width of doorway

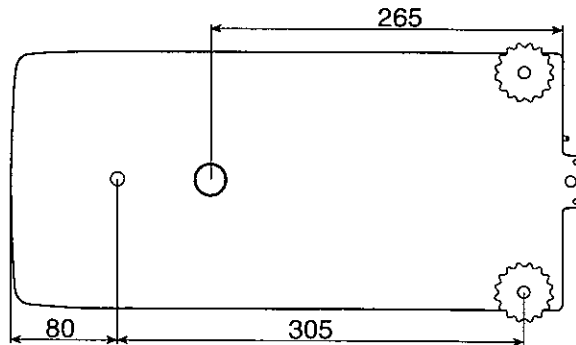



Errors

Over load Error

E

This display indicates that the weight placed on the pan is beyond the balance capacity.

Weighing pan Error

-E

This display indicates that the weighing pan or the pan support are not properly installed.

Power failure Error

P FAIL

This display indicates that power was interrupted during weighing the last time the balance was used. Press the **ON:OFF** key to clear.

Stability Error

Error 1

This display indicates that the balance can not become stable while zeroing or weighing.

Check for excessive vibration or drafts. Press the **RE-ZERO** key to clear.

Digital Input Error

Error 2

This display indicates that an unacceptable Digital value was input. Press the **RE-ZERO** key to clear.

Position error for internal mass

Error 6

This is a position error for the internal mass.

Confirm that there is nothing touching the pan. Turn on the balance once more.

Zero-point Error

This display indicates that the zero-point of weighing has drifted from last calibrating zero-point, make certain that there is nothing on the weighing pan.

Execute calibration to reset the zero-point.

CAL Errors

CAL E

This display indicates that the calibration mass is too heavy.

-CAL E

This display indicates that the calibration mass is too light.

Unit weight Error

Lo

The samples are too light to calculate the unit weight in the percent mode. Increase the weight of the sample.

❑ **Sample quantity Notice**

XX -

If samples are lighter than the minimum value, the counting error becomes too large and the balance requests that you add the required number of samples. Count and place the requested samples on the pan. Press the **RANGE** key to store the correct value.

xx - is the quantity to add

Error 0

Error 3

Error 4

Error 7

Error 8

Error 9

The balance needs repair. Request service from the store where you purchased the balance, or from the A&D service group.

