

Digital Scale

HL-WP Series

INSTRUCTION MANUAL



HL-1000WP
HL-300WP
HL-3000WP
HL-3000LWP

AND

A&D Company, Limited

SAFETY PRECAUTIONS

All safety messages are identified by the following, “**WARNING**” or “**CAUTION**”, of ANSI Z535.4 (American National Standard Institute: Product Safety Signs and Labels). The meanings are as follows:

 WARNING	A potentially hazardous situation which, if not avoided, could result in death or serious injury.
 CAUTION	A potentially hazardous situation which, if not avoided, may result in minor or moderate injury.

- ❑ This manual is subject to change without notice at any time to improve the product.
- ❑ Product specifications are subject to change without any obligation on the part of the manufacture.
- ❑ When using the HL-WP, the following safety precautions should always be followed.

 **WARNING** **Use only the specified AC adapter for the scale. Other adapters may cause damage (The AC adapter is optional). Internal service or adjustments to this product should be performed by a qualified person.**

 **CAUTION** Avoid installing the scale in direct sunlight, which may cause discoloration or malfunctions.

Do not mix the type of batteries. Replace all the batteries at the same time.

If the scale is not to be used for a long period of time, remove all batteries from the battery compartment to avoid leakage.

Avoid overloading that could cause damage to the scale.

Avoid using the weighing pan to move the scale, as that could cause damage to the scale.

When the scale is used with an AC adapter, the scale does not conform to IP-65 protection.

IP65

Degree of protection against water: Protected against water jets.
Degree of protection against solid foreign objects: Dust-tight.
IP Code (Degree of protection provided by enclosures) of IEC 60529

PARTS DESCRIPTION

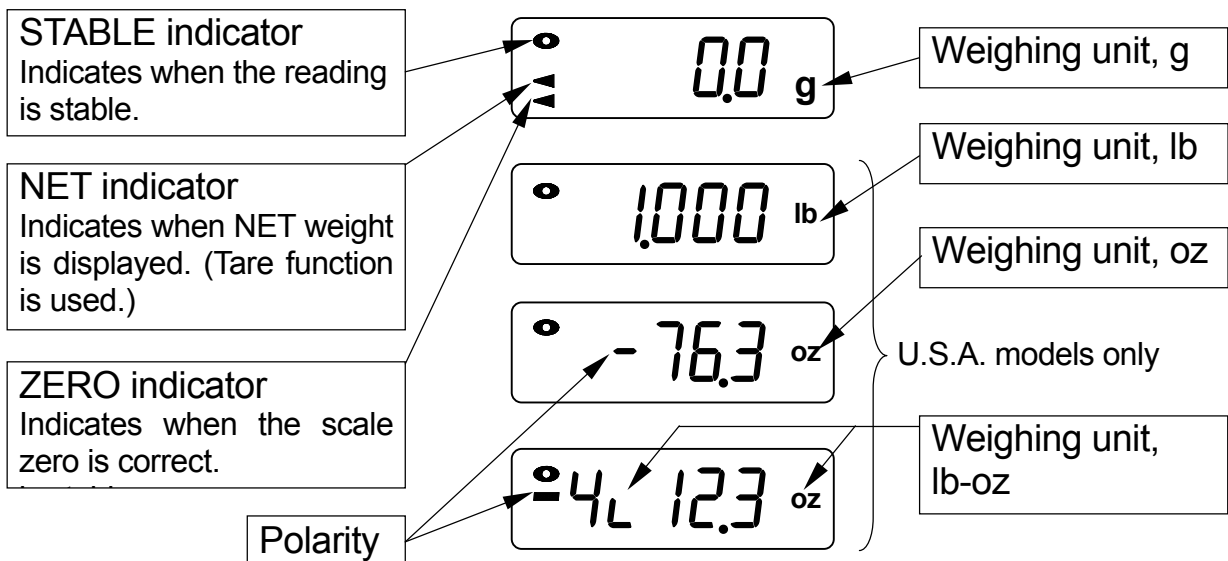
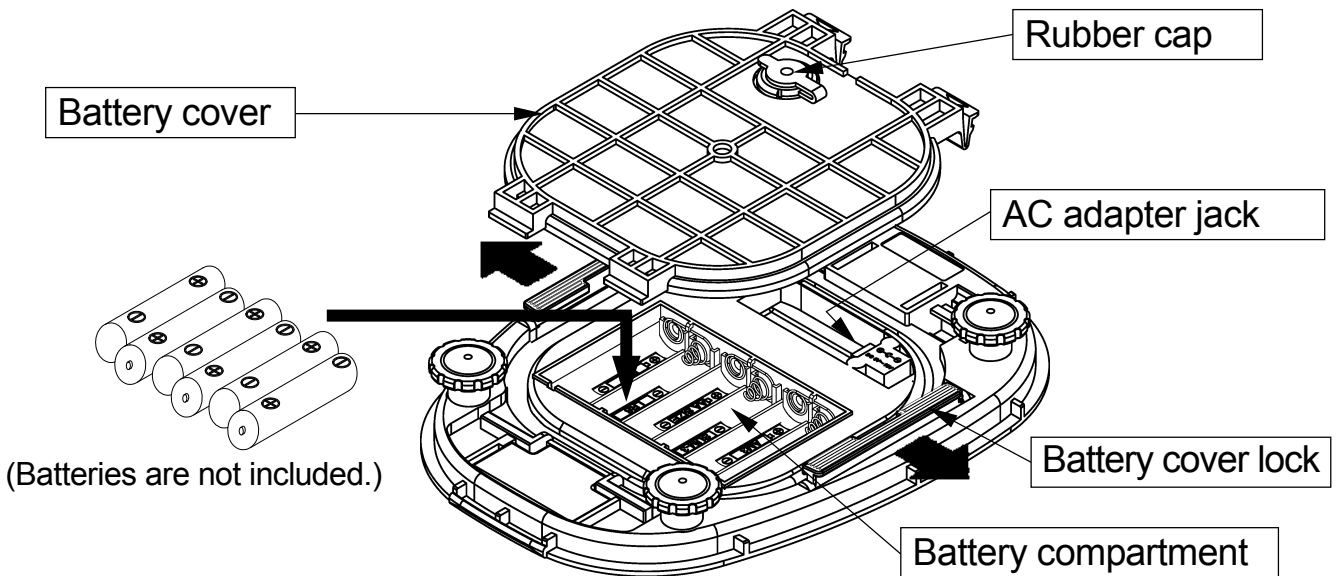
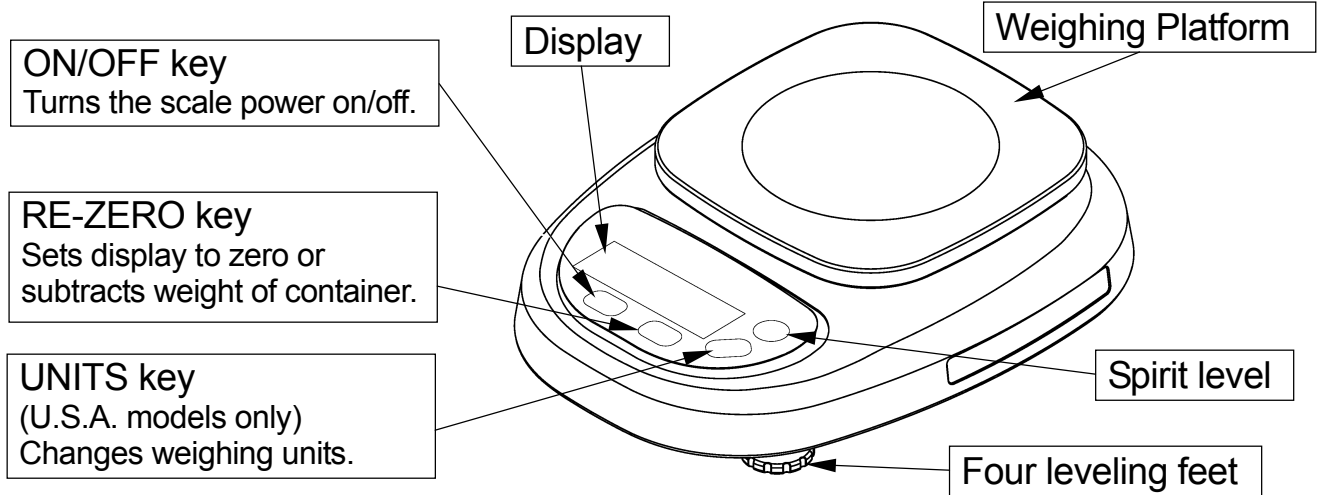

PREPARATION

Installing Batteries / Connecting The AC adapter

Installing Batteries

⚠ CAUTION

When replacing batteries, be careful not to apply too much force to the weighing pan. An excessive force could damage the scale.

Remove the battery cover and insert six batteries (R6P / LR6 / AA size) into the battery compartment, taking extreme care to that the polarities plus and minus are observed. Be sure to lock the battery cover again after installing the batteries.

Close the rubber cap

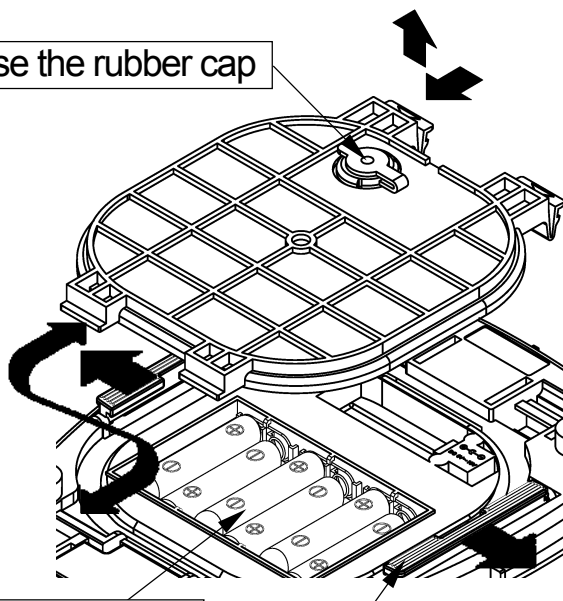

New six batteries (R6P/ LR6/ AA size)

Battery cover lock

AC adapter (optional)

⚠ CAUTION

When using an AC adapter, the scale does not comply with the IP65.

The AC input requirement could be 100, 120, 220, 230 or 240 volts (50/60Hz) depending on the area where used, so please verify that the adapter is correct.

Plug the AC adapter to the AC adapter socket inside the battery compartment.

Attach the battery cover and fit the rubber cap.

Optional AC Adapter

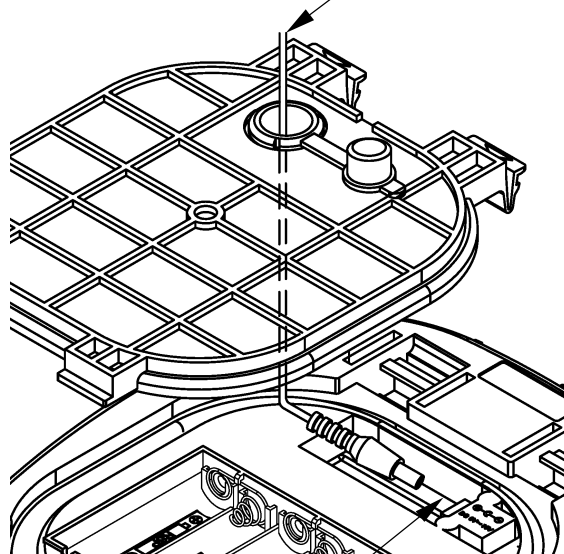

AC Adapter jack

Setting up the HL-WP

⚠ CAUTION

Avoid installing the scale in direct sunlight, as that may cause discoloration or a malfunction. Place your HL-WP on a firm weighing table so that the scale is level. (The scale will not perform accurately when it is not level.)

Place the scale on the firm surface and adjust the feet so that the spirit level shows the scale is level for an accurate weighing.

WEIGHING

Before weighing

Automatic Power-Off Function

If the scale is left ON and the stable indicator is displayed, the automatic power-off function turns the power off after approximately 5 minutes (factory setting). To toggle the function disabled/enabled, press the [ON/OFF] key while pressing the [RE-ZERO] key. The scale stores the setting and it will be shown by pressing both the [RE-ZERO] and [UNITS] keys in the weighing mode. (See “CALIBRATION” about the [UNITS] key.)

PoFF0 Function disabled. PoFF1 Function enabled.

Error message

E	Overload
-----	The scale zero is out of range
Lb	Low battery

Calibration may be required before weighing

Read “CALIBRATION” first and if necessary, calibrate your scale for accurate weighing.

Weighing procedures

1. Turn on the scale.

Press the [ON/OFF] key to turn on the scale. Then the scale displays all segments for a few seconds and then 0 will be displayed.

2. Start weighing

If you do not use a container for weighing,

Verify the reading is 0. If not, press the [RE-ZERO] key to display 0. Place objects on the weighing platform to weigh. When the reading becomes stable, the stable indicator is displayed.

If you use a container for weighing,

Place an empty container on the platform.

Wait for the stability indicator to be displayed and press the [RE-ZERO] key. Place the objects to be weighed in the container.

Select the weighing unit, --- Only for U.S.A. models ---

If you use the U.S.A. model, press the [UNITS] key to select weighing unit. Normally scales power up in “lb” or “oz” when shipped from the factory. To power up in other units, turn the scale off. Press and hold the [UNITS] key, then press the [ON/OFF].key The scale will start with the next unit.

Note) HL-300WP: oz→g→oz→

HL-1000WP/3000WP/3000LWP: lb→oz→lb-oz→g→lb→

CALIBRATION

When to calibrate

Calibration may be required when the scale initially installed, if it is moved a substantial distance, or in accordance with local regulations. This is necessary because the weight of a mass in one location is not necessarily the same in another location. Also, with time and use, mechanical deviations can occur.

The position of the [UNITS] key for the Calibration

The “g” model has no [UNITS] key, but the key used to enter calibration is located under the overlay.

Location of the [UNITS] key

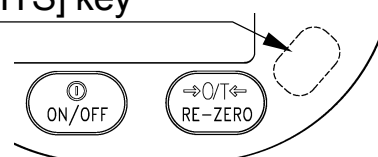

Calibration using a calibration weight

Calibrate the scale with calibration weights at full capacity.

HL-1000WP :	1000g ± 0.1g
HL-300WP:	300g ± 0.02g
HL-3000WP :	3000g ± 0.2g
HL-3000LWP :	3000g ± 0.2g

1. Enter calibration mode.

Press the [ON/OFF] key to turn the power off.

While pressing both the [RE-ZERO] key and the [UNITS] key, press the [ON/OFF] key. [CAL] will be displayed.

2. Zero calibration

Press the [RE-ZERO] key to calibrate zero. [CAL 0] will be displayed.

Wait for the stable indicator to be displayed and press the [RE-ZERO] key.

[CAL F] will be displayed in a few seconds. If only the zero calibration is to be done, press the [UNITS] key. The scale will display [End] and automatically return to the weighing mode.

3. Span calibration

Place the weight at the center of the platform for accurate calibration. Wait for the stable indicator to be displayed and then press the [RE-ZERO] key. The display will show [End] and the scale will automatically return to the weighing mode.

Gravity compensation

If you have calibration weights at the capacity of the scale, you can calibrate the scale with the weights instead of compensating for acceleration due to gravity.

The scale was calibrated at 9.798 m/sec^2 , at the factory. If the acceleration due to gravity at your location is not same, compensate the scale by adjusting the acceleration due to gravity. (Refer “The Value of Gravity at Various Locations” and “World Map” and find your location value.)

1. Enter calibration mode.

Press the [ON/OFF] key to turn the power off. While pressing both the [RE-ZERO] key and the [UNITS] key, press the [ON/OFF] key. CAL will be displayed.

2. Select a digit to be changed.

Press the [UNITS] key. The previously set value, for example 9798, will be displayed. A digit after the comma “,” will be changed by pressing the [RE-ZERO] key. Press the [UNITS] key to move the comma “,” and select a digit to be changed.

3. Set the new value

Change the value of the gravity acceleration using the [RE-ZERO] and [UNITS] keys.

4. Save the value in memory.

Press and hold the [UNITS] key until End is displayed. The scale will automatically return to the weighing mode.

SPECIFICATIONS

MODEL	HL-1000WP	HL-300WP	HL-3000WP	HL-3000LWP
Capacity	1000 x 0.5 g	300 x 0.1 g	3000 x 1 g	
x	2.2 x 0.001 lb		6.6 x 0.002 lb	
Resolution	35.28 x 0.02 oz	10.58 x 0.01 oz	105.8 x 0.1 oz	
	2 lb 3.3 x 0.1 oz		6 lb 9.8 x 0.1 oz	
Non-linearity	±1g	±0.2g	±2g	
Repeatability	0.5g	0.1g	1g	
Span drift	±0.015% / °C TYP (5°C~35°C / 41°F~95°F)			
Operating temp.	-10°C~40°C / 14°F~104°F, Less than 85%RH			
Display	13 mm / 0.51 inches, 7segment liquid crystal display			
Display update	Approximately 10 times per second			
Power	6 x R6P / LR6 / "AA" size batteries or AC adapter			
Battery life	Approximately 100 hours with manganese type 200 hours with alkaline cells at 20°C / 68°F			
Platform size	128 (W) x 128 (D) mm 5.0 (W) x 5.0 (D) in.		174(W)x137(D) mm 6.8(W)x5.4(D) in.	
Dimensions	170 (W) x 219 (D) x 63 (H) mm 6.7 (W) x 8.6 (D) x 2.5 (H) in.		174(W)x219(D)x63(H) mm 6.8(W)x8.6(D)x2.5(H) in.	
Weight (approx.)	870 g / 1.9 lb		950 g / 2.1 lb	
Calibration weight	1000g ± 0.1g	300g ± 0.02g	3000g±0.2g	
Accessories	This manual			
Options	AC adapter			

The Value of Gravity at Various Locations

Amsterdam	9.813 m/s ²	Manila	9.784 m/s ²
Athens	9.807 m/s ²	Melbourne	9.800 m/s ²
Auckland NZ	9.799 m/s ²	Mexico City	9.779 m/s ²
Bangkok	9.783 m/s ²	Milan	9.806 m/s ²
Birmingham	9.813 m/s ²	New York	9.802 m/s ²
Brussels	9.811 m/s ²	Oslo	9.819 m/s ²
Buenos Aires	9.797 m/s ²	Ottawa	9.806 m/s ²
Calcutta	9.788 m/s ²	Paris	9.809 m/s ²
Cape Town	9.796 m/s ²	Rio de Janeiro	9.788 m/s ²
Chicago	9.803 m/s ²	Rome	9.803 m/s ²
Copenhagen	9.815 m/s ²	San Francisco	9.800 m/s ²
Cyprus	9.797 m/s ²	Singapore	9.781 m/s ²
Djakarta	9.781 m/s ²	Stockholm	9.818 m/s ²
Frankfurt	9.810 m/s ²	Sydney	9.797 m/s ²
Glasgow	9.816 m/s ²	Taichung	9.789 m/s ²
Havana	9.788 m/s ²	Taiwan	9.788 m/s ²
Helsinki	9.819 m/s ²	Taipei	9.790 m/s ²
Kuwait	9.793 m/s ²	Tokyo	9.798 m/s ²
Lisbon	9.801 m/s ²	Vancouver, BC	9.809 m/s ²
London (Greenwich)	9.812 m/s ²	Washington DC	9.801 m/s ²
Los Angeles	9.796 m/s ²	Wellington NZ	9.803 m/s ²
Madrid	9.800 m/s ²	Zurich	9.807 m/s ²

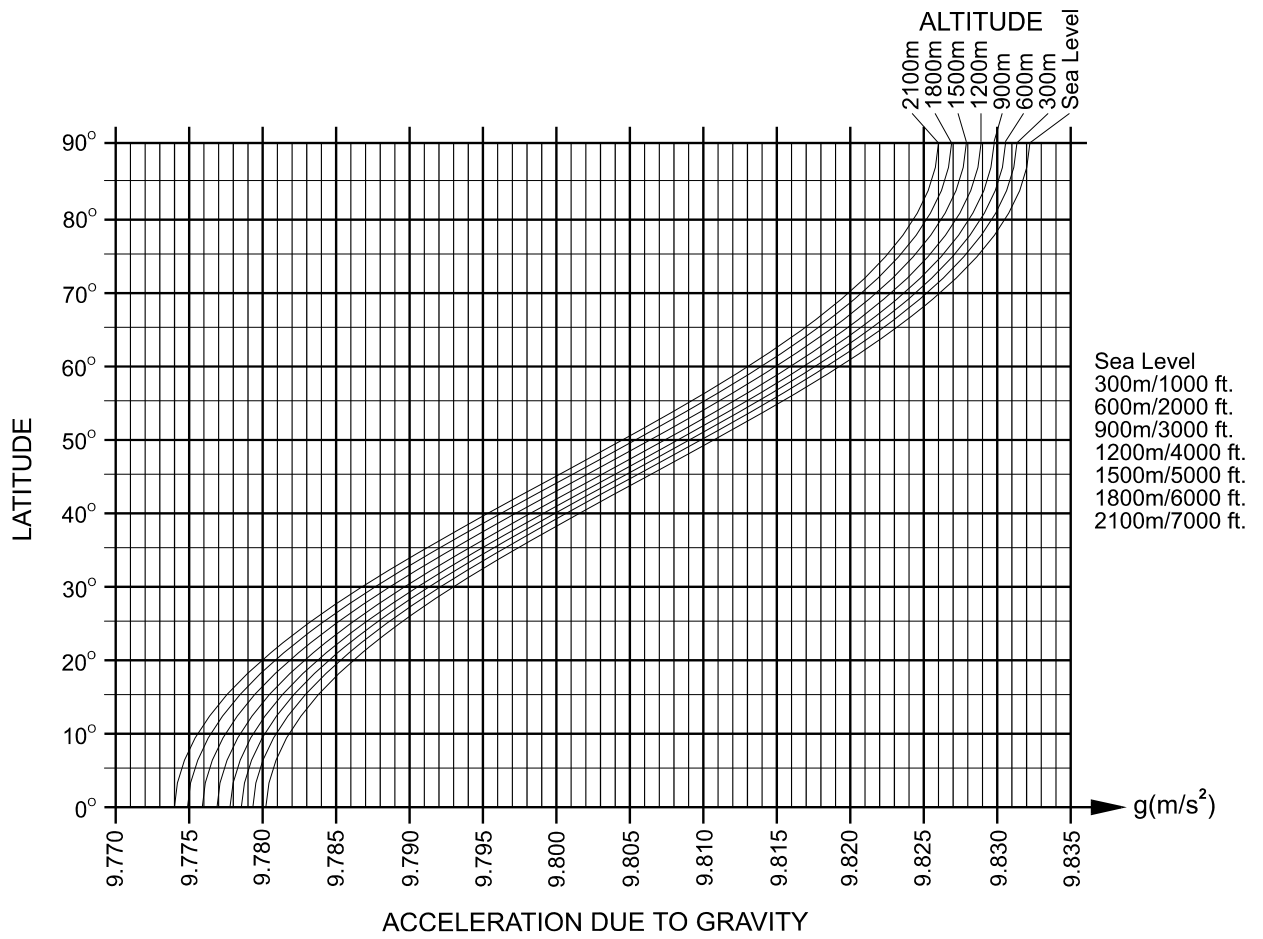

World Map

