

## Simplified Instruction Manual

AD-4212F-6203D  
AD-4212F-10202  
AD-4212F-22001

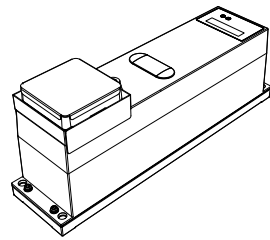

View the product page.

Refer to the detailed instruction manual on the product page: [https://link.aandd.jp/ad4212f\\_en/](https://link.aandd.jp/ad4212f_en/)

### About this manual

- No parts of this manual may be reproduced without permission. This manual may not be copied, modified, or translated without the written permission of A&D Company, Limited.
- The contents of this manual are subject to change without notice.
- Please contact A&D if you notice any uncertainty, errors, omissions, etc. in this manual.
- A&D Company, Limited bears no liability for direct, indirect, special, or consequential damages due to the operation of the product, even if advised of the possibility of such damage. Furthermore, A&D assumes no liability for claims of rights from third parties. Concurrently, A&D assumes no liability whatsoever for data losses regardless of (3) above.

© 2023 A&D Company, Limited

1WMPD4004757B



## Safety Precautions

To prevent accidents due to inappropriate handling, this manual contains the following warning signs and marks. The meanings of these warning signs and marks are as follows.



**A potentially hazardous situation which, if not avoided, may result in personal injury or property damage.**

Before use, confirm the following items for safe operation.

### CAUTION

- Never disassemble, modify or repair the weighing unit by yourself.
- The power line used for the weighing unit should be dedicated to it and should be separate from other driving equipment.
- Do not perform operations near the power supply with wet hands.
- Do not use in a place where gasoline, thinner, or combustible gas may leak.
- Use in an environment with a temperature of 5°C to 40°C and a humidity of 85%RH or less.
- Do not poke the diaphragm or packing of the weighing unit with a sharp object.
- The dustproof and waterproof level of the weighing unit is equivalent to IP65, and its second digit, "5", corresponds to "having no harmful influence by receiving direct jet of water". Washing with strong water pressure or submersion in water may cause water to enter the weighing unit and cause a malfunction.
- When installing and using the weighing unit under conditions requiring dustproof and waterproof performance, make sure that the AC adapter plug is fully inserted into the AC adapter jack and that the signal cable is attached.
- When not using the AC adapter or the communication cable, keep the rubber caps of the packing sections closed.
- Do not apply impact to or drop the weighing unit.
- When transporting the weighing unit, use the packing material in which the weighing unit was originally packed.
- The weighing unit may affect hearing aids, pacemakers, other electrical medical devices, fire alarms, automatic doors, and other automated devices. Do not use the weighing unit nearby this kind of equipment as it may cause malfunction or accident.

## 1. Introduction

This manual is an outline of the AD-4212F (the weighing unit) and the instructions for setting up and installing the weighing unit. Refer to the A&D website for more information on operation methods, specifications, and communication methods.

[https://link.aandd.jp/ad4212f\\_en/](https://link.aandd.jp/ad4212f_en/)

## 2. Features

- The compact weighing unit has a width of only 80 mm, making it ideal for incorporating into production lines.
- The electromagnetic balance sensor ensures high resolution and high-speed response.
- The weighing unit outputs digital data, so it can be connected directly to a personal computer (PC) or programmable logic controller (PLC).
- Dustproof and waterproof (IP65 compliant).
- The WinCT-AD4212F data communication software makes it easy to check weighing values on a Windows PC. In addition, filter settings can be easily applied as needed for the operating environment, required response speed, or desired accuracy, by being graphically simulated.
- Connect the AD-8922A or AD-8923-BCD/CC (sold separately) to manually read weighing values, rezero, and adjust sensitivity.
- In addition to standard RS-232C communication, various accessories enable BCD output, comparator output, analog output, RS-485 communication, CC-Link, Modbus RTU, and Ethernet/IP.

## 3. Product Structure (Part Names)

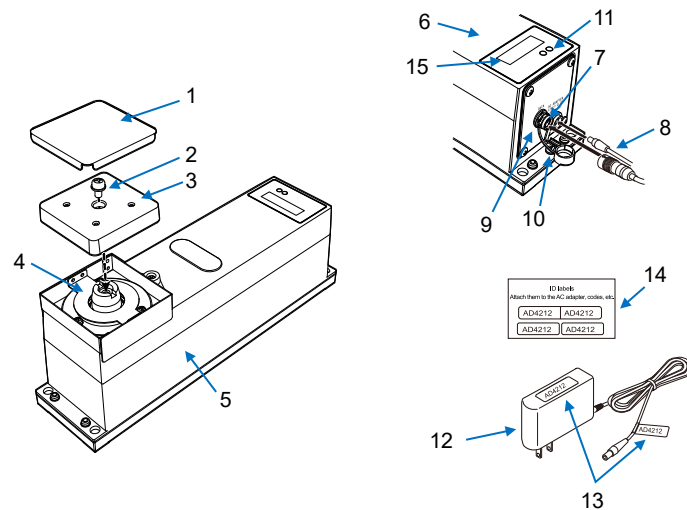

No.	Name
1	Weighing pan
2	Screw for fixing pan support (Pan head screw: M5 screws x 10)
3	Pan support
4	Pan support boss
5	Main body
6	Rear of the main body
7	AC adapter jack
8	AC adapter plug
9	RS-232C output connector *1
10	Grounding terminal
11	Indicator lights
12	AC adapter *2
13	Positions of AC adapter ID labels
14	AC adapter ID labels
15	Serial number

\*1 The connection cable is sold separately.

\*2 Please confirm that the AC adapter type is correct for your local voltage and receptacle type.

## 4. Precautions for Assembly and Installation

### Fixing to the platform

For stable weighing, be sure to fix the main body to the installation platform with screws.

When screwing from the top: M6 screws x 4  
When screwing from the bottom: M8 screws x 4  
Be careful of the following when assembling and installing the unit.

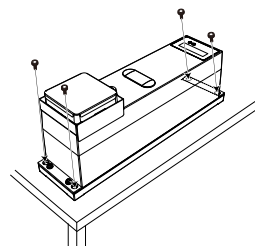

### CAUTION

- Do not apply excessive rotational force or pressing force when fixing the weighing pan to the pan support boss.
- Do not apply any pulling up or side forces to the pan support boss.
- Do not apply impact to the weighing pan.

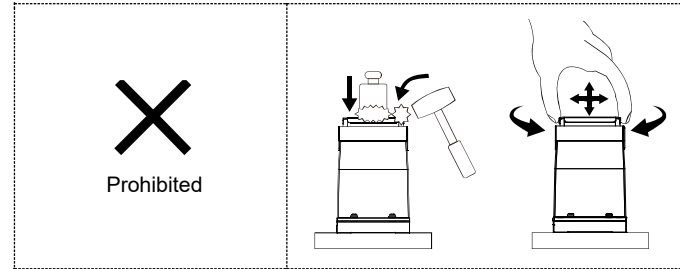

Be sure to ground the weighing unit.

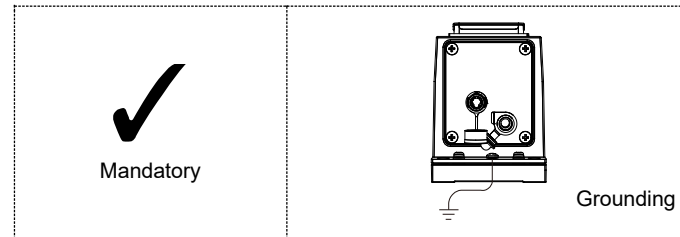

Wire the power line and signal line to ensure distance from power supplies for driving equipment and other lines that carry large currents.

## 5. Precautions for More Accurate Weighing

For precise and accurate weighing, please take notice of the following.

### CAUTION

- Avoid impact when placing the weighing object on the weighing pan. This can lead to weighing errors and malfunctions of the weighing unit.
- Perform sensitivity adjustment before using the weighing unit for the first time or after having moved it to another location. In addition, perform sensitivity adjustment periodically to maintain the accuracy.
- Install the weighing unit in a location that is free of dust or vibration.
- A suitable location for weighing is on the first (ground) floor of a building, near a wall rather than in the middle of a room because these locations are less prone to vibration.
- We guarantee the performance of the weighing unit in a non-moving state. If the weighing unit is built into a system which is to be moved, make sure that it is level when stationary and is housed in a structure that is resistant to vibration. Avoid sudden movements, stops, or impact, and make sure that any fluctuations in weighing values due to movement have sufficiently subsided before acquiring data.
- The weighing unit is dustproof and waterproof in compliance with IP65. However, clean and control the area around the pan when measuring powders, liquids, metal fragments, etc.
- The best operating conditions are a stable environment of 20 °C ± 2 °C and 45% to 60% RH. To minimize temperature fluctuations, install the weighing unit where it is not exposed to direct sunlight.
- Do not install in a location where it will be exposed to air flow from air conditioners or other equipment. Air flow and temperature changes may cause errors in the weighing value.
- Temperature difference between the ambient temperature and the weighing object (including the tare) may result in weighing errors due to convection currents around the weighing object or temperature changes in the weighing unit. Take measures as necessary, such as insulating with a dedicated jig pan.

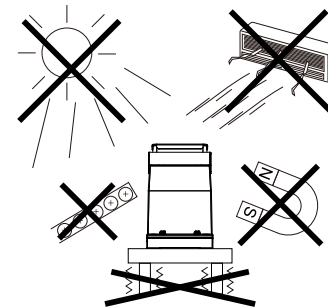

- Air flow may cause the weighing value to become unstable. Avoid installing the weighing unit near doorways or corridors. Also, do not use compressed air to move the object to be weighed to the weighing pan.
- Install the weighing unit away from equipment which produces magnetic fields.
- The electrostatic charge (static electricity) of the object to be weighed or the nearby jig may cause fluctuations in the weighing value. Insulators such as plastic, glass, etc. are easily charged with static electricity in environments with humidity of 45%RH or less.
- Install on a level platform. If levelling is not possible, be sure to perform sensitivity adjustment in that installation condition.
- When fabricating a dedicated weighing pan, make sure that the surface area is as small as possible to reduce fluctuations in weighing values due to drafts, and that the material used is rigid and conductive to prevent static electricity from charging.
- Be sure to connect the AC adapter connected to the power supply to warm up the weighing unit before use for at least half an hour.
- When not weighing at the center of the weighing pan, install the weighing unit so that the total moment of the jig and the object to be weighed is less than the specified value. (For details, refer to the instruction manual on A&D website.)
- To reduce measurement error, use the command to perform a zero reset before every weighing, or calculate the weighing value by the difference before and after weighing.

## 6. Connection and Weighing Value Confirmation (RS-232C)

- How to connect and disconnect the cable\*  
\*The connection cable is sold separately.

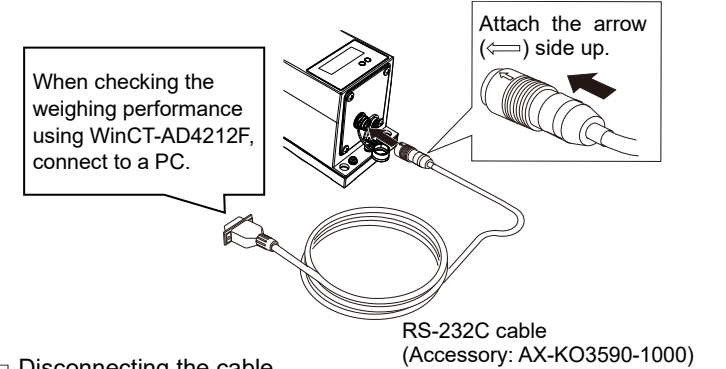

### Disconnecting the cable

Slide the connector sleeve (the part marked with an arrow) to unlock the connector, and then pull out the connector.

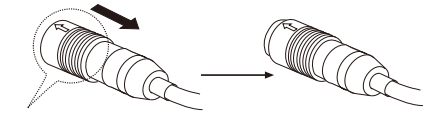

Slide to unlock

Unlocked

### Cable pin assignments

(when using the accessory cable AX-KO3590-1000)

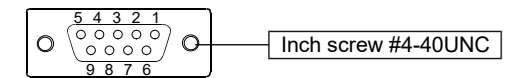

D-sub 9-pin female

With the accessory cable AX-KO3590-1000

No.	Signal name	Direction	Description
1	Vs	-	Internally used, power supply for external equipment: GND
2	TXD	Output	Transmit data
3	RXD	Input	Receive data
4	-	-	N.C.
5	SG	-	Signal ground
6	DSR	Output	Data set ready
7	RTS	Input	Request to send
8	CTS	Output	Clear to send
9	Va	-	Internally used, power supply for external equipment: Output terminal

### RS-232C factory settings

Item	Setting
Baud rate	2400 bps
Data bits	7 bits
Parity	EVEN
Stop bit	1 bit
Codes used	ASCII
Data format	A&D standard format
Data output mode	Continuous output mode

□ Output data (RS-232C)

Example of weighing data (A&D standard format)

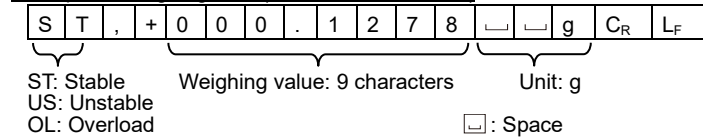

Example of display control data

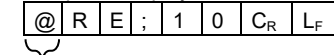

Data with "@" at the beginning is control data for when a display unit is connected. Ignore this data during communication with a PLC via RS-232C.

□ How to check with an AD-8922A or AD-8923CC/BCD  
Connection diagram

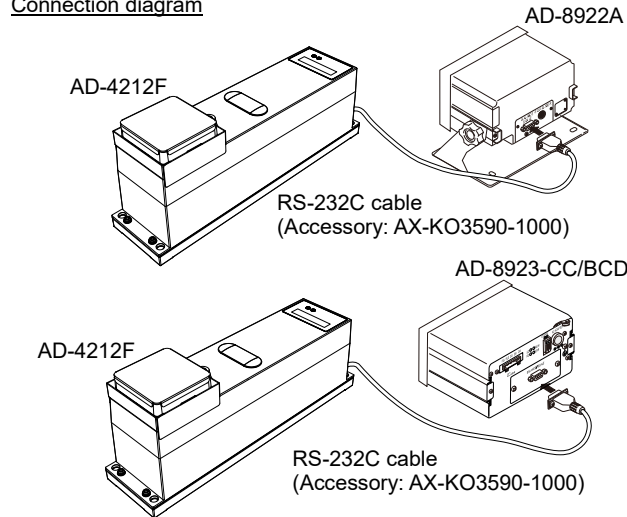

Settings

If all the connected devices are set to the factory settings, the weighing value will be displayed only by connecting the cable and power supply. If the settings have been changed, refer to details in each instruction manual, match the RS-232C settings of the connected devices, and set the data output of the weighing unit to continuous output mode.

□ How to check with a personal computer (PC)  
Connection diagram

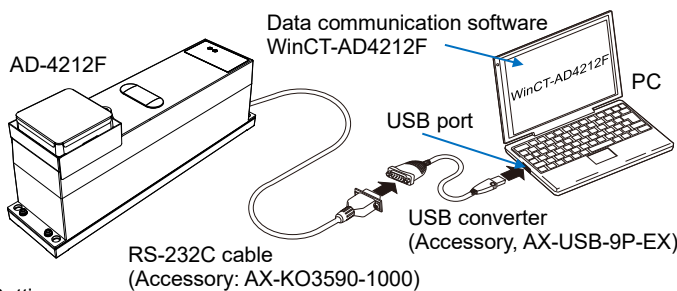

Settings

- Download the WinCT-AD4212F installer from our website.
  - Install WinCT-AD4212F on your PC. Refer to the WinCT-AD4212F Readme for the installation method.
  - Set the COM port of WinCT-AD4212F on your PC and press the START button. The weighing value will be displayed on the PC screen.\*
- \*If the weighing value is not displayed, make sure the baud rate settings of the weighing unit and the PC match and that the data output mode of the weighing unit is set to continuous output.

□ How to connect with a PLC  
Connection diagram

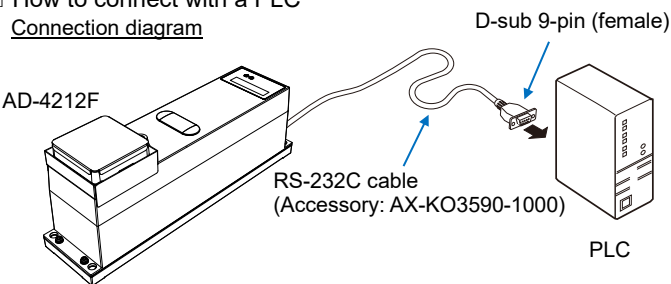

Settings

Adjust settings according to your PLC.  
For RS-232C settings and the data format of the weighing unit, refer to "6. Connection and Weighing Value Confirmation (RS-232C)".  
Continuous output mode is set as the factory setting and weighing data is output continuously from the weighing unit. To change the output mode, refer to "7. Frequently Used Commands (for RS-232C)".

7. Frequently Used Commands (for RS-232C)

By sending the following commands externally via RS-232C, the corresponding operation can be performed. Send commands from your PLC or PC.

Command	Description (Function)
C	Set temporarily to command mode. The weighing value is output upon data request from the host. The setting is canceled when the power is cut.
Q	Immediately request the weighing value. (The weighing value is output regardless of whether it is stable or unstable. Note that continuous output mode must be disabled.)
S	Request the weighing value after stabilization. (The weighing value is output after it becomes stable. Note that continuous output mode must be disabled.)
SIR	Set temporarily to continuous output mode. Weighing values are output continuously. The setting is canceled when the power is removed. (C command to stop continuous output.)
PR:00	Set to command mode. A data request from the host outputs the weighing value. The setting is retained even after power is cut.
PR:03	Set to continuous output mode. Weighing values are output continuously. The setting is retained even after power is cut.
?PRT	Check the data output mode setting. For command mode, the response is Pr.00. For continuous output mode, the response is Pr.03. Temporary settings by the C command or SIR command are not reflected in this response.
R	Set the weighing value to zero (tare).
CAL	Enter calibration mode.
U	Switch the weighing speed (response characteristics).
SMP	Switch the readability.

8. How to Use RS-485

For the weighing unit, use the accessory cables AX-KO7522-500 (5 m), AX-KO7622-200 (2 m), and the RS-485 interface (AD4212F-29) to enable communication via the RS-485 interface. With RS-485, multiple units can be connected in a daisy-chain connection. Setting individual device addresses allows communication with each unit by adding the device addresses to the commands to be sent and received. The AX-KO7522-500 can supply power to the weighing unit.

□ Connection diagram

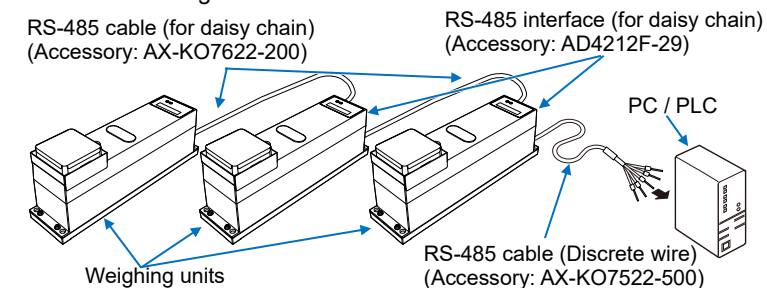

□ Cable wiring (with the accessory cable AX-KO7522-500)

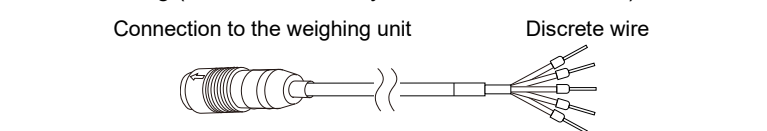

When using the accessory cable AX-KO7522-500

Lead wire	Signal name	Direction	Description
Yellow	DC+	Input / Output	Power supply (12 V DC)*
Yellow / White	GND	Input / Output	Power supply (0 V)
Blue	DATA+	Input / Output	RS-485 signal line
Blue / White	DATA-	Input / Output	RS-485 signal line
Black	FG	-	Frame ground

\*Supplies power to the weighing unit. 12 V is output when power is supplied directly to the weighing unit using the included AC adapter. When supplying power to the weighing unit, make sure that its voltage is correct. Once power is supplied, please do not let the terminals of discrete wire touch one another or anything around them, or do not touch them by hand.

RS-485 factory settings

Item	Setting
Baud rate	2400 bps
Data bits	7 bits
Parity	EVEN
Stop bit	1 bit
Codes used	ASCII
Device address	0
Termination resistor	None (Open)
Data format	A&D standard format
Data output mode	Command mode

□ How to set device address and termination resistor

Remove the screws (at the four corners) to remove the rear panel.

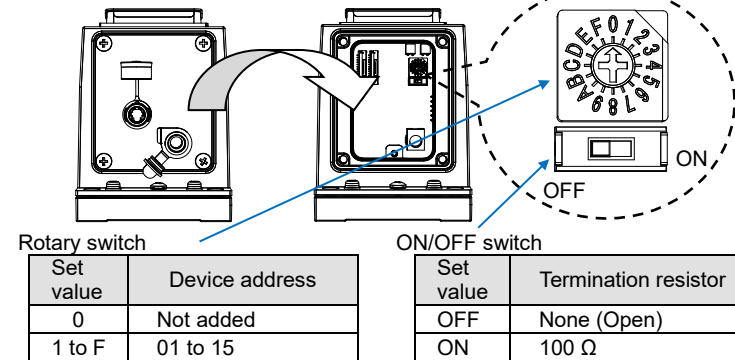

□ Output data (RS-485)

Weighing data with "@\*\*" at the beginning (\*\* represents the set device address) is output. (Unlike RS-232C, data for display unit control is not output.)

Example of weighing data (A&D standard format)

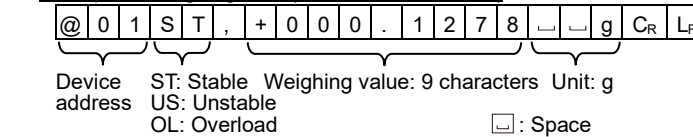

□ Transmission data (RS-485)

RS-232C commands can be used with a device address added to the beginning. The unit with the matching device address will respond.

Example of sending a request command for weighing data

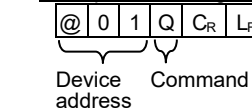

9. Specifications

	AD-4212F-6203D	AD-4212F-10202	AD-4212F-22001
Weighing capacity	510 g / 6200 g	10200 g	22000 g
Readability	0.001 g / 0.01 g	0.01 g	0.1 g
Repeatability	0.002 g / 0.01 g	0.01 g	0.1 g
Stabilization time in seconds*1	With 0.001 g readability: 1.3 sec*2 With 0.01 g readability: 1.0 sec	0 to 300 g: 0.5 sec 300 to 10200 g: 1.0 sec	0 to 300 g: 0.5 sec 300 to 22000 g: 1.0 sec
Data refresh rate	100 times / second*3		
Power supply (AC adapter)	Please confirm that the AC adapter type is correct for your local voltage and receptacle type.		
Power consumption	Approx. 30 VA (including the AC adapter)		
Current consumption	12 V DC Approx. 0.3 A (excluding the adapter and optional accessories)		
Main body weight	Approx. 3.2 kg		
Dustproof / waterproof	IP65 compliant		

\*1 When the stability band width is set to ±3 digits and [FAST] is selected for the weighing speed (response characteristics) in a good environment.  
\*2 When the precision range is used.  
\*3 The baud rate must be set to 19200 bps or higher.

□ External dimensions

(Unit: mm)

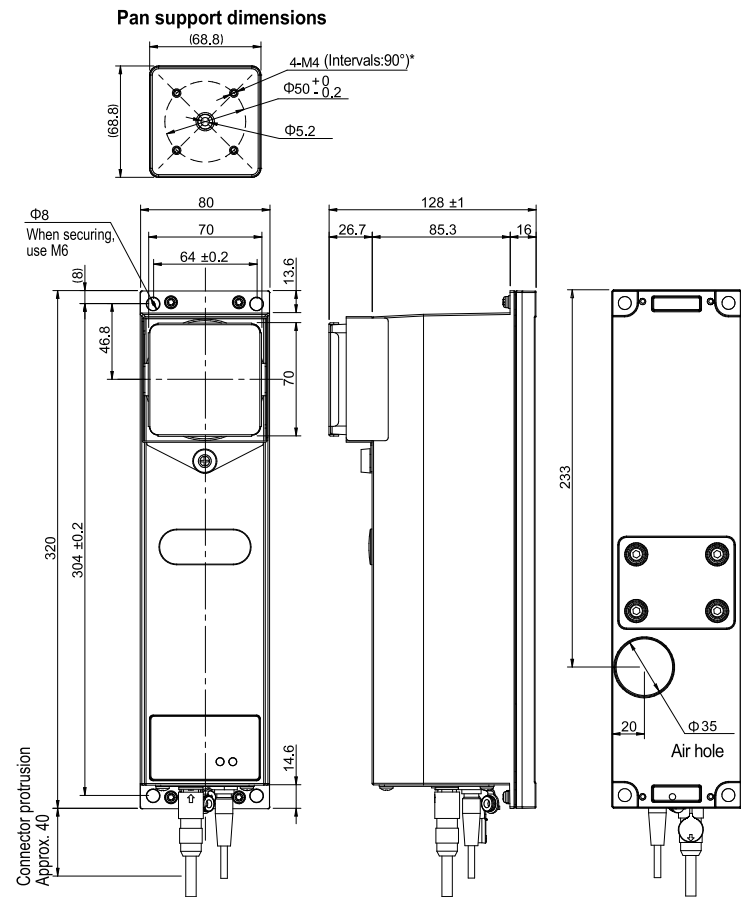

\*The screw holes to secure the exclusive weighing pan created by customers.

10. Indicator Lights

The two indicator lights on the top of the weighing unit indicate the following states.

Color	When	Description
Green	Lit	Power is on.
	Blinking	Blinks correspond to the baud rate setting * (Only when power supply begins.)
Red	Lit	Non-weighing values (e.g., zero, sensitivity adjustment in progress, etc.) are output.
	Blinking	Warning that impact has been applied to the weighing unit

\* See below for the number of blinks and the corresponding baud rate setting, and how to count the number of blinks.

Number of blinks	Baud rate
1	600 bps
2	1200 bps
3	2400 bps
4	4800 bps
5	9600 bps
6	19200 bps
7	28800 bps
8	38400 bps
9	115200 bps

E.g.) Number of blinks: 3 (2400 bps)

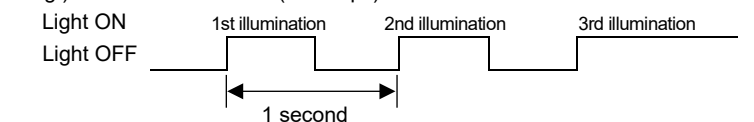

11. Accessories

The connection cable is not included. Please purchase the accessory cables that are suitable for your needs.

AX-KO3590-200	RS-232C cable	2 m
AX-KO3590-500	RS-232C cable	5 m
AX-KO3590-1000	RS-232C cable	10 m
AX-KO7522-500	RS-485 cable (discrete wire)	5 m
AX-KO7622-200	RS-485 cable (for daisy chain)	2 m
AX-USB-9P-EX	USB converter cable set	
AD4212F-29	RS-485 interface (for daisy chain)	