

BA-TE SERIES

Analytical Balances

QUICK START GUIDE

BA-6TE

BA-6DTE

BA-225TE

BA-225DTE

BA-125DTE

© 2021 A&D Company Ltd. All rights reserved.

No part of this publication may be reproduced, transmitted, transcribed, or translated into any language in any form by any means without the written permission of A&D Company Ltd.

The contents of this manual and the specifications of the instrument covered by this manual are subject to change for improvement without notice.

Windows, Word and Excel are registered trademarks of the Microsoft Corporation.

Contents

1.	Quick Start Guide	4
1.1.	Detailed Manuals	4
2.	Assembly and Installation	4
2.1.	Unpacking	5
2.2.	Assembly	6
3.	Installation Considerations, Weighing Preparation and Precautions	9
3.1.	How to adjust the level of the balance	9
4.	On-Screen Buttons and Key Panel (Basic Operation)	10
5.	IR sensors and Automatic Doors	12
5.1.	IR sensors	12
5.2.	Automatic doors	12
6.	Check Function	13
7.	Sensitivity Adjustment / Calibration Test	14
7.1.	Automatic sensitivity adjustment	14
7.2.	Sensitivity adjustment using the internal mass	14
8.	Typical Errors (Error Codes)	15
9.	Ionizer (AX-ION-25)	17
9.1.	Using the Ionizer	17
10.	Specifications	18
11.	Compliance	19
11.1.	Compliance with FCC Rules	19
11.2.	IC	19

1. Quick Start Guide

Thank you for purchasing an A&D BA-TE series analytical balance. This quick start guide describes how to install the BA-TE series balance, and it covers the basic functions and main operations of the balance. For further information about the BA-TE series balance, please refer to the separate instruction manuals listed in "1.1. Detailed Manuals".

1.1. Detailed Manuals

Detailed manuals are available for download from the A&D website (<https://www.aandd.jp>):

BA-TE Series Instruction Manual

This is the manual to help you understand the functions and operations of the BA-TE series in detail and make full use of them.

Ionizer (static eliminator) Instruction Manual

This is the manual describing the functions of the AX-ION-25 ionizer and instructions on use.

2. Assembly and Installation

Caution

- A BA-TE series analytical balance is a precision instrument, and it should be carefully unpacked. It is advisable to store the packing materials so that they can be used when transporting the balance.
- The contents of the package vary depending on the product. Refer to the illustration of the packing contents and make sure that everything is included.
- Do not connect the AC adapter to the balance until the balance is assembled and installed.
- When the balance is ready, connect the AC adapter. An operation check will be performed automatically.
- Use the dedicated AC adapter specified for the balance.
- Do not connect the included AC adapter to other devices.
- If you use the wrong AC adapter, the balance and other equipment may not work properly.
- Make sure that the AC adapter is unplugged before you connect the ionizer.
- The BA-TE series analytical balance is composed of the weighing unit and display unit. It is not possible to replace just one of the units.

2.1. Unpacking

Packing contents common to BA-TE series

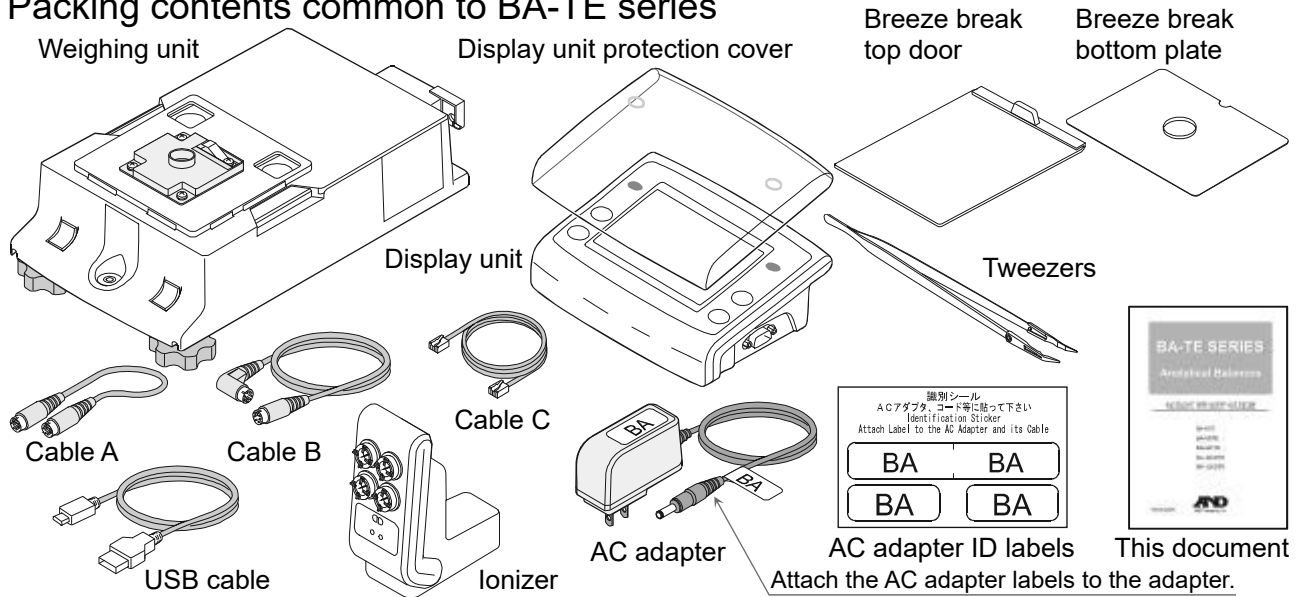

Packing contents for BA-6TE / BA-6DTE

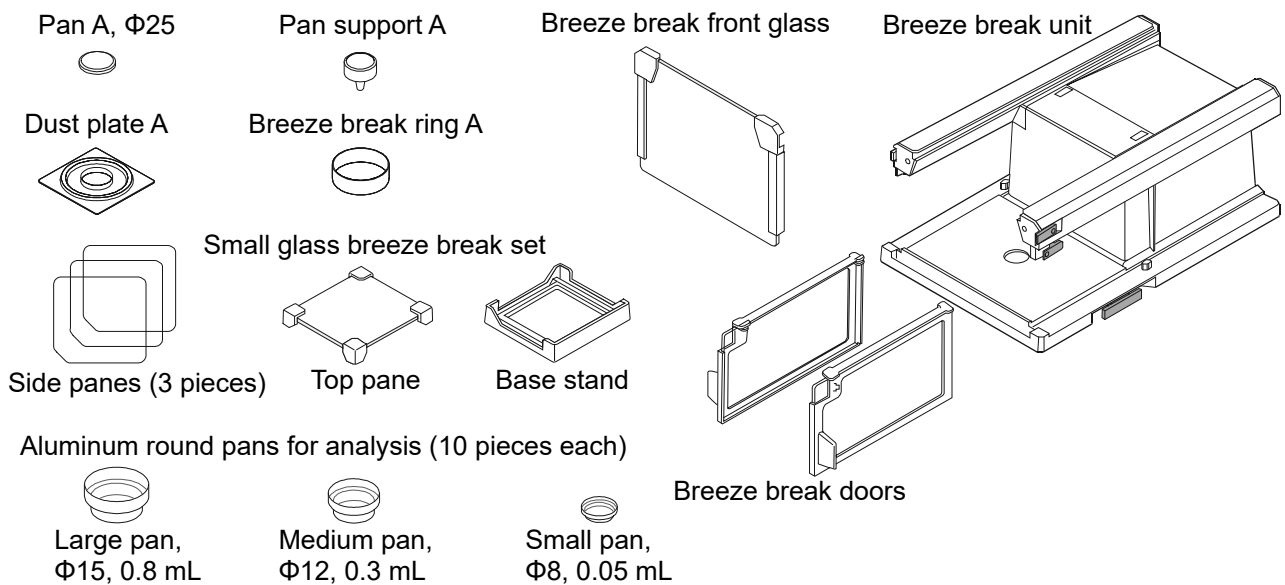

Packing contents for BA-225TE / BA-225DTE / BA-125DTE

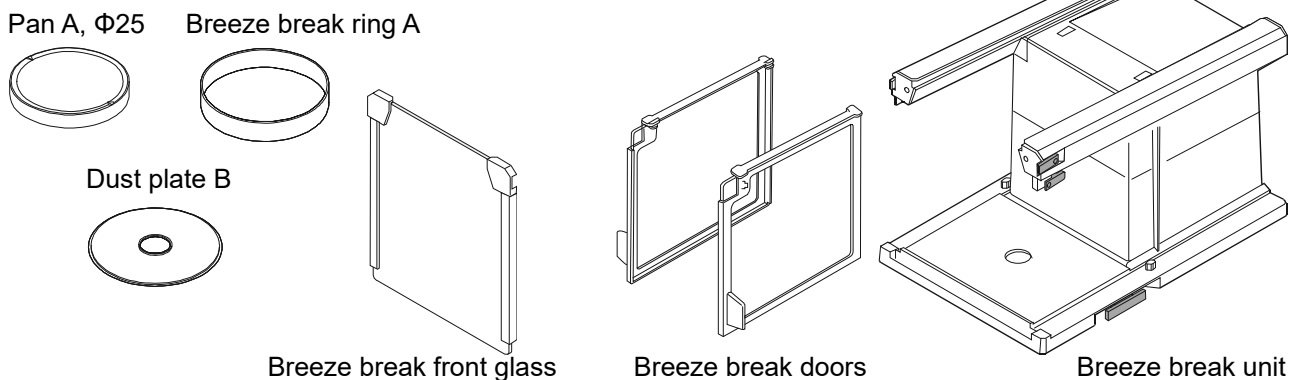

2.2. Assembly

The BA-6TE is used here for the example of assembly. Other models can be assembled in the same way.

Step 1 Pull out the breeze break locking handles.

Step 2 Place the breeze break unit on the weighing unit.

Step 3 Push in the breeze break locking handles to secure the units to each other.

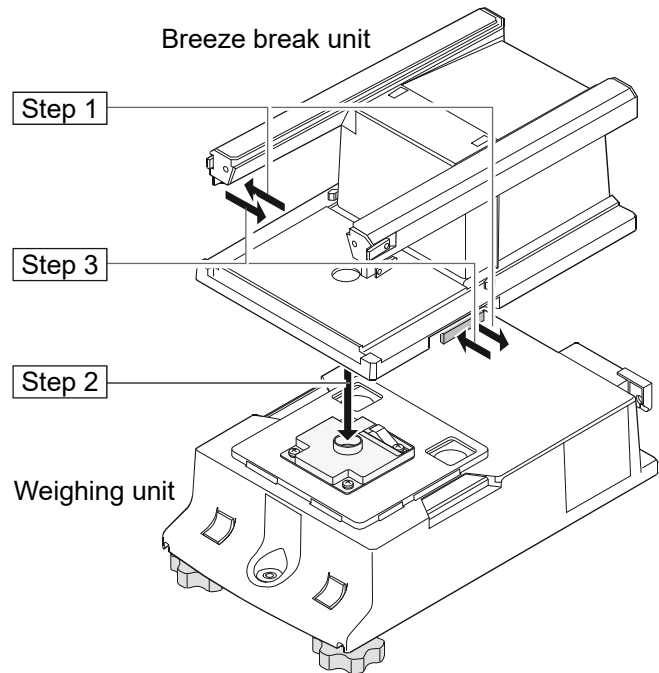

Step 4 Assemble the weighing pan.

For BA-6TE / BA-6DTE, assemble the five parts of the weighing pan in the correct position by referring to the cross-sectional view.

For BA-225TE / BA-225DTE / BA-125DTE, assemble the four parts of the weighing pan in the correct position by referring to the cross-sectional view.

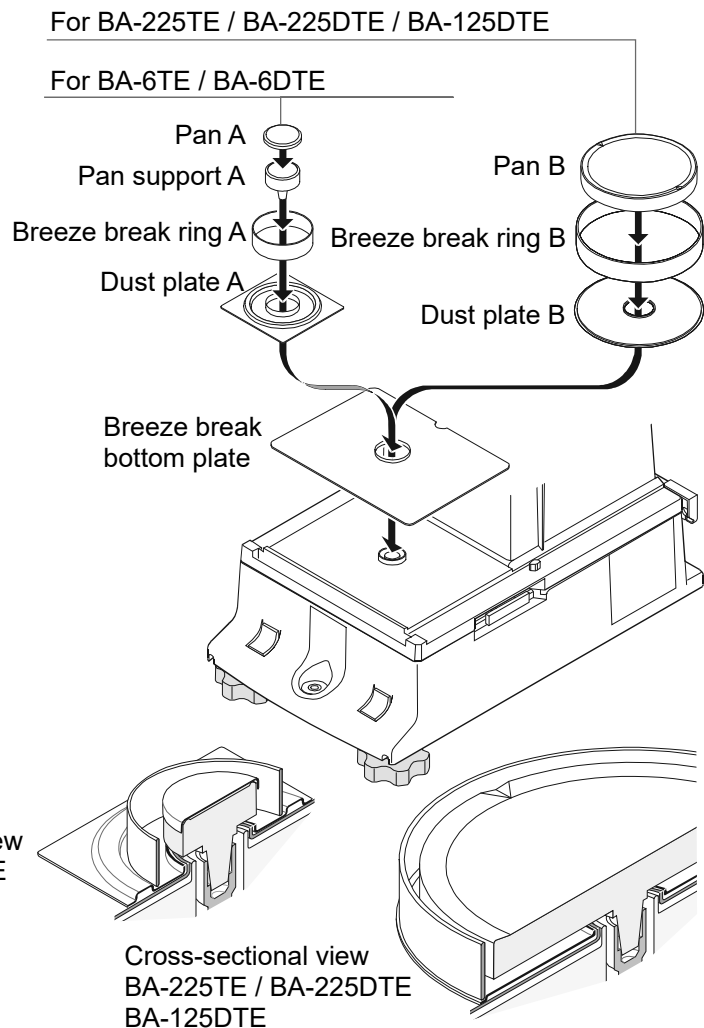

Step 5 Assemble the glass breeze break.

Assemble the BA-6TE / BA-6DTE glass breeze break in the weighing chamber. Align the side panes with the notch of the base stand.

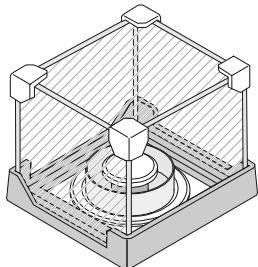

Example of the small breeze break with the right side open.

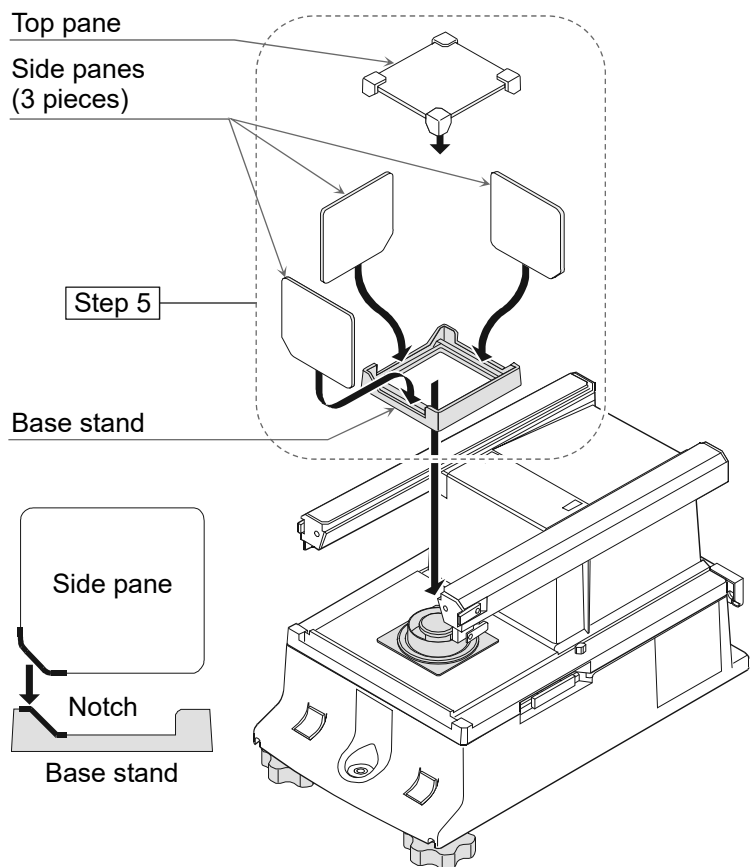

Step 6 Insert the breeze break top door from the handle side.

Step 7 Assemble the breeze break doors on the left and right sides.

7a Insert the breeze break doors on the left and right sides.

7b Secure the breeze break doors with the latches.

Step 8 Assemble the breeze break front glass.

8a Insert the breeze break front glass.

8b Secure the breeze break front glass with the latches.

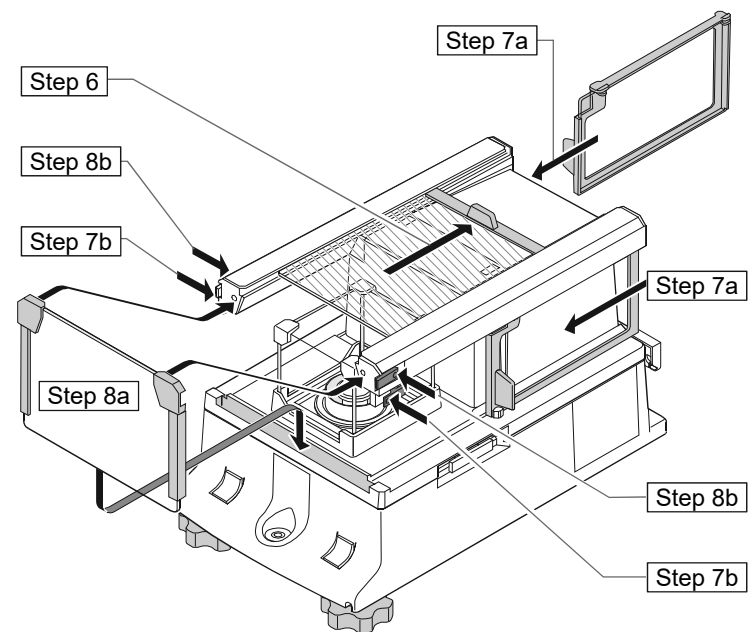

- Step 9 Using the included cable A and cable B, connect the "weighing unit" and "breeze break unit" and the "display unit" and "weighing unit" respectively, paying attention to the direction of the arrow on each cable.
- Step 10 Connect the breeze break unit and ionizer with the included cable C.
- Caution** The ionizer operates when the AC adapter is connected to the balance.
- Step 11 Connect the included AC adapter to the balance.

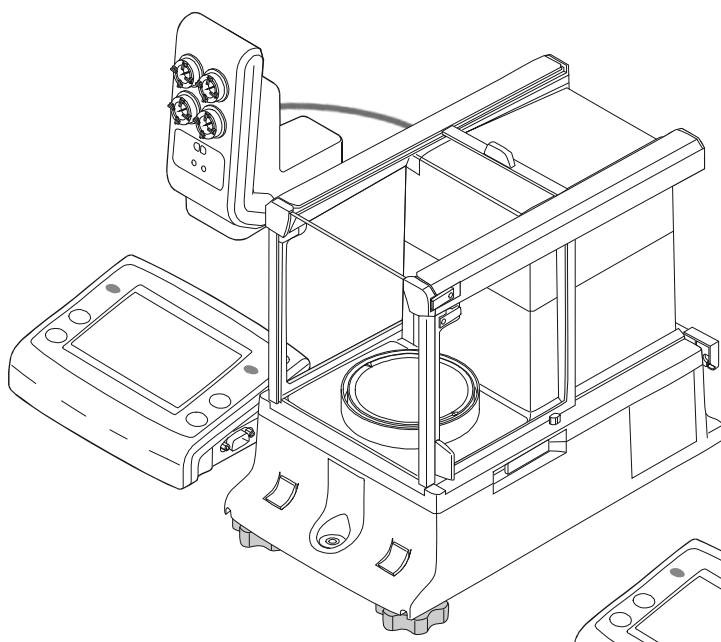
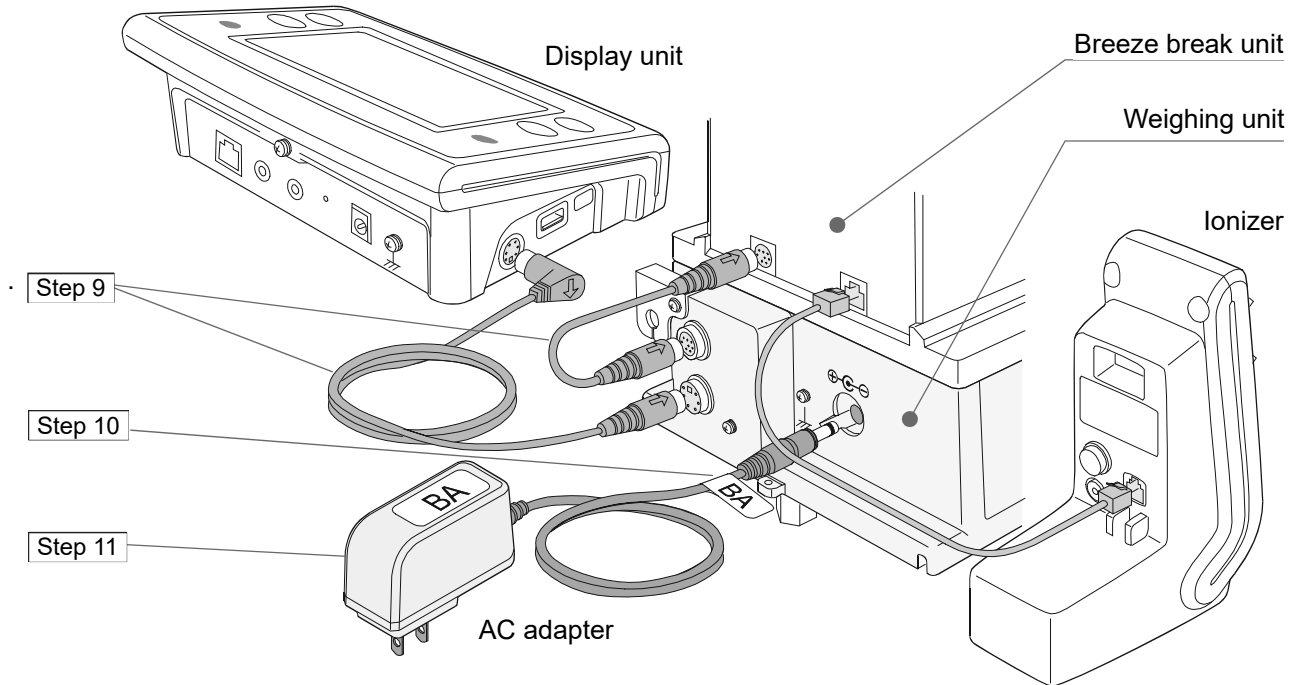

BA-225TE / BA-225DTE / BA-125DTE

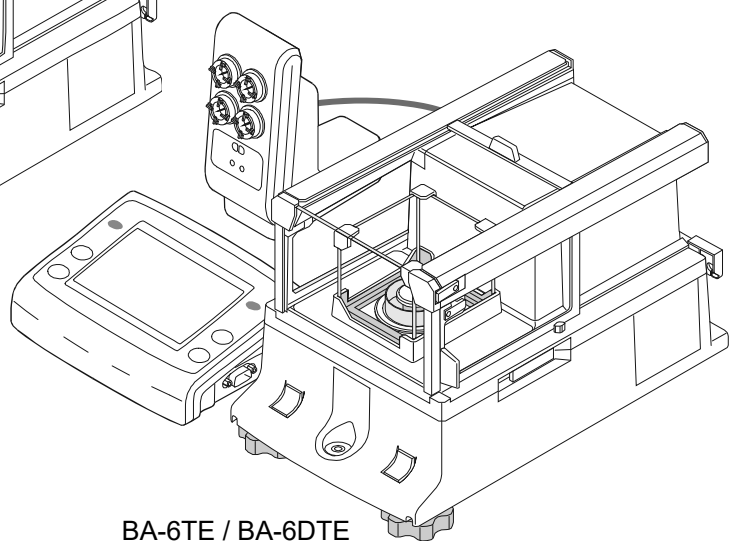

BA-6TE / BA-6DTE

3. Installation Considerations, Weighing Preparation and Precautions

Prepare the following installation conditions in order to bring out the full performance of the balance.

- Install the balance in an environment where the temperature and humidity are not excessive. The best operating temperature is about 20°C ±2°C at about 45% to 60% RH relative humidity.
- Install the balance where it is free of dust.
- The weighing table should be solid. (An anti-vibration table or stone table is ideal)
- Place the balance on a horizontal table, and make sure that it is not tilted.
- Install the balance in a stable location, avoiding vibration and shock. Corners of rooms on the first floor are best, as they are less prone to vibration.
- Install the balance where it is not affected by heaters or air conditioners.
- Install the balance where it is not exposed to direct sunlight.
- Install the balance away from equipment which produces magnetic fields.
- Level the weighing unit with the leveling feet and bubble spirit level. Refer to “3.1. How to adjust the level of the balance”.
- Be sure to warm up the balance before use for at least an hour, or at least four hours for BA-6TE / BA-6DTE, with the AC adapter connected to the power supply.
- Perform sensitivity adjustment of the balance before using it for the first time or after having moved it to another location so that accurate weighing can be performed. For details, refer to the detailed instruction manual listed in “1.1. Detailed Manuals”.

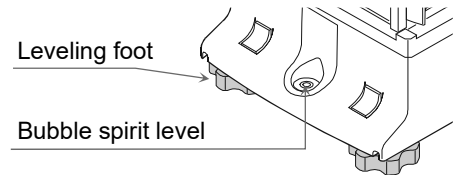

Caution Do not install the balance where flammable or corrosive gas is present.

3.1. How to adjust the level of the balance

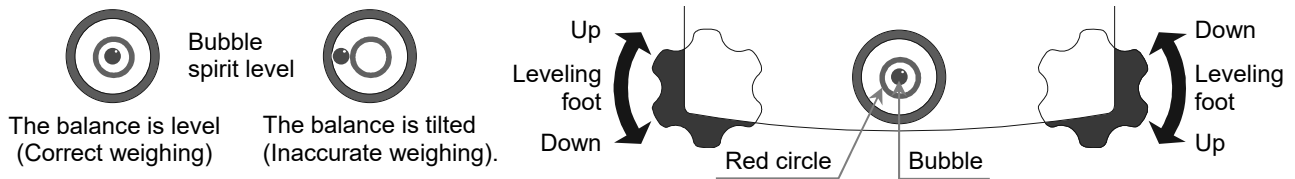

- Level the balance by adjusting the leveling feet so that the bubble of the bubble spirit level is centered in the red circle.

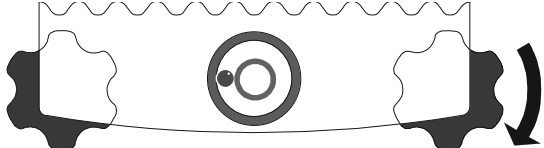
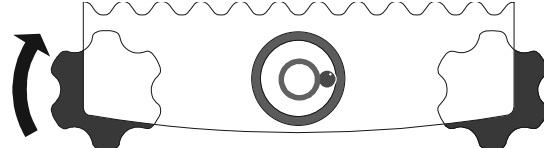
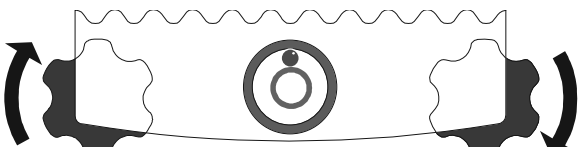
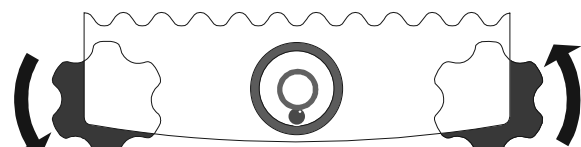
<p>When the bubble is off to the left. Turn the leveling foot on the front right in the clockwise direction.</p> 	<p>When the bubble is off to the right. Turn the leveling foot on the front left in the clockwise direction.</p> 
<p>When the bubble is off to the backward position. Turn both leveling feet on the front in the clockwise direction at the same time.</p> 	<p>When the bubble is off to the forward position. Turn both leveling feet on the front in the counter clockwise direction at the same time.</p> 

4. On-Screen Buttons and Key Panel (Basic Operation)



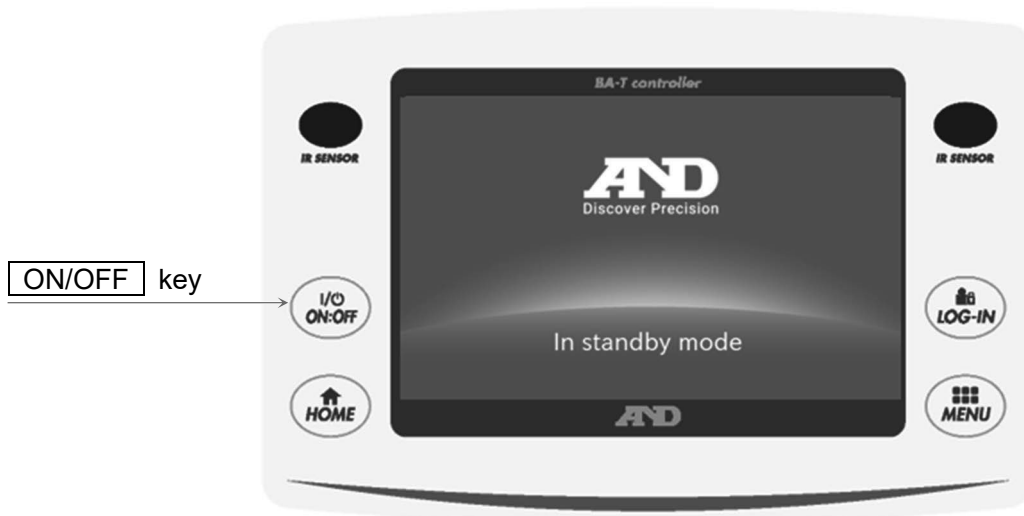



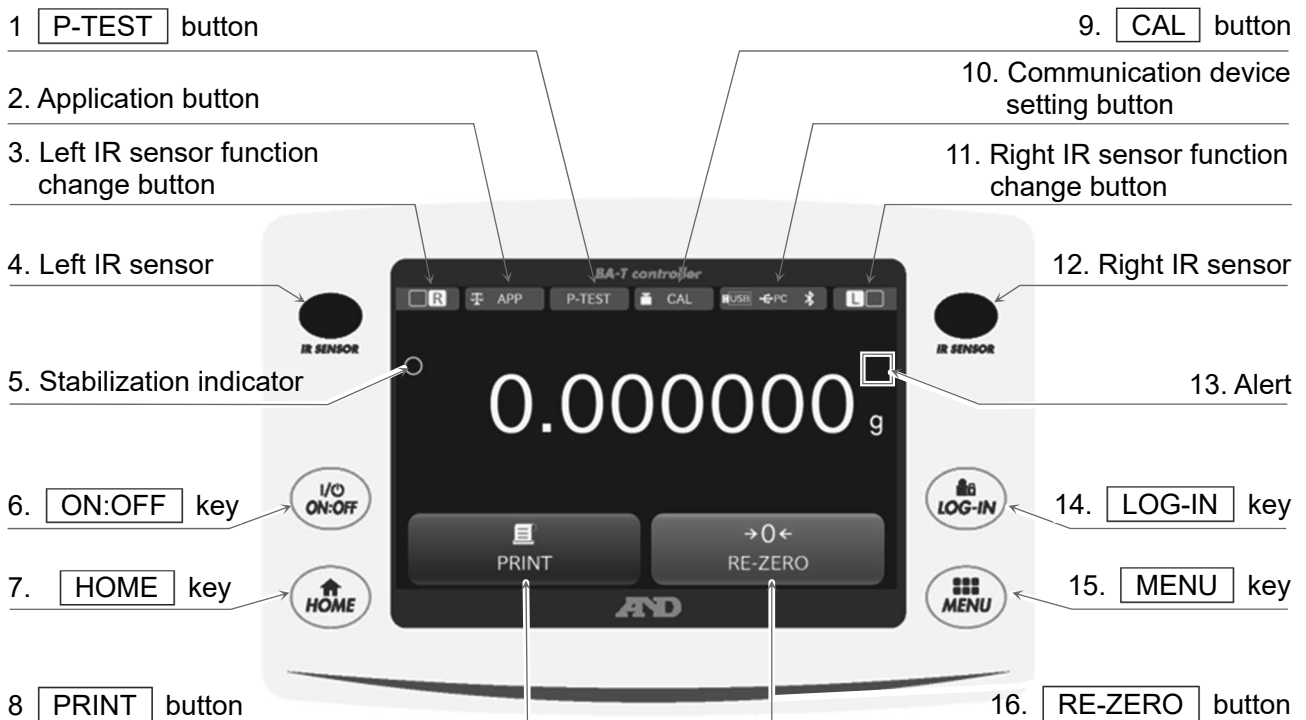



Standby screen





Weighing screen

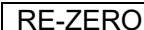

Key / button operation

1	 button	Runs a quick performance test. The quick performance test automatically checks the performance of the balance by loading and unloading the internal mass. For details, refer to the separate instruction manual listed in "1.1. Detailed Manuals".
2	Application button	Displays the application setting screen. For details, refer to the separate instruction manual listed in "1.1. Detailed Manuals".
3	Left IR sensor function change button	Changes the operation set for the IR sensors. At factory setting, the button opens/closes the breeze break door.
4	Left IR sensor	This is one of the IR sensors (touchless sensor). When you bring your hand close to it, it reacts and the assigned breeze break door opens/closes. For details, refer to "5.2. Automatic doors".
6	 key	Turns the screen display on and off. The  key is active during any operation. When the displayed screen is turned off, the standby screen appears. When the screen display is turned on, the weighing screen appears.
7	 key	Displays the weighing screen. The  key is active during any operation.
8	 button	Outputs data to the device connected to the balance. For details, refer to the separate instruction manual listed in "1.1. Detailed Manuals".
9	 button	Displays the sensitivity adjustment / calibration screen. For details, refer to the separate instruction manual listed in "1.1. Detailed Manuals".
10	Communication device setting button	Displays the communication device setting screen. Configures the settings of the connected communication device.
11	Right IR sensor function change button	Changes the operation set for the IR sensors. At factory setting, opens/closes the breeze break door.
12	Right IR sensor	This is one of the IR sensors (touchless sensor). When you bring your hand closer, it reacts and the assigned breeze break door opens/closes. For details, refer to "5.2. Automatic doors".
14	 key	Displays the log-in screen. The  key is active at any time, and pressing this key during operation always displays the log-in key. For details, refer to the separate instruction manual listed in "1.1. Detailed Manuals".
15	 key	Displays the MENU screen. The  key is active at any time when the key is in operation.
16	 button	Sets the displayed value to zero.

	Alert	Name	Description	Display priority
13		Static elimination recommended	Displayed when the humidity inside the balance is 45% or less. (Lights up for about 30 seconds after the start of weighing)	Higher
		Door open/close	Displayed when the breeze break door is open.	Lower

5. IR sensors and Automatic Doors

5.1. IR sensors

BA-TE series analytical balances are equipped with IR sensors that allow operation without directly touching the balance display. At factory setting, the IR sensors on the left and right of the display are assigned to open and close the breeze break doors. You can set **OR** / **LD** to turn the left and right IR sensors on and off, or change them to operate other functions.

5.2. Automatic doors

BA-TE series analytical balances are equipped with automatic doors that allow you to open/close the breeze break without touching the doors.

The IR sensors on the left and right of the display are assigned settings to open/close the breeze break doors on the right and left respectively.

At factory setting, each breeze break door opens to the position it was previously opened to.

It is also possible to change which sensors the breeze break doors are assigned to and for the doors to be fully open or partially open in the function table of the balance.

For details, refer to the separate instruction manual listed in “1.1. Detailed Manuals”.

Opening the breeze break door

Step 1. If you want to open the breeze break door on the left side (or on the right side) when it is closed, hold your hand over the right IR sensor (or the left IR sensor).

Step 2. The detection buzzer sounds and the breeze break door on the left (or right) side opens.

Caution With BA-6TE / BA-6DTE, the breeze break doors stop at the partially-open position at factory setting.

Closing the breeze break door

Step 1. If you want to close the breeze break door on the left side (or on the right side) when it is open, hold your hand over the right IR sensor (or the left IR sensor).

Step 2. The detection buzzer sounds and the breeze break door on the left (or right) side closes.

Operation overview

The left IR sensor opens/closes the door on the right.

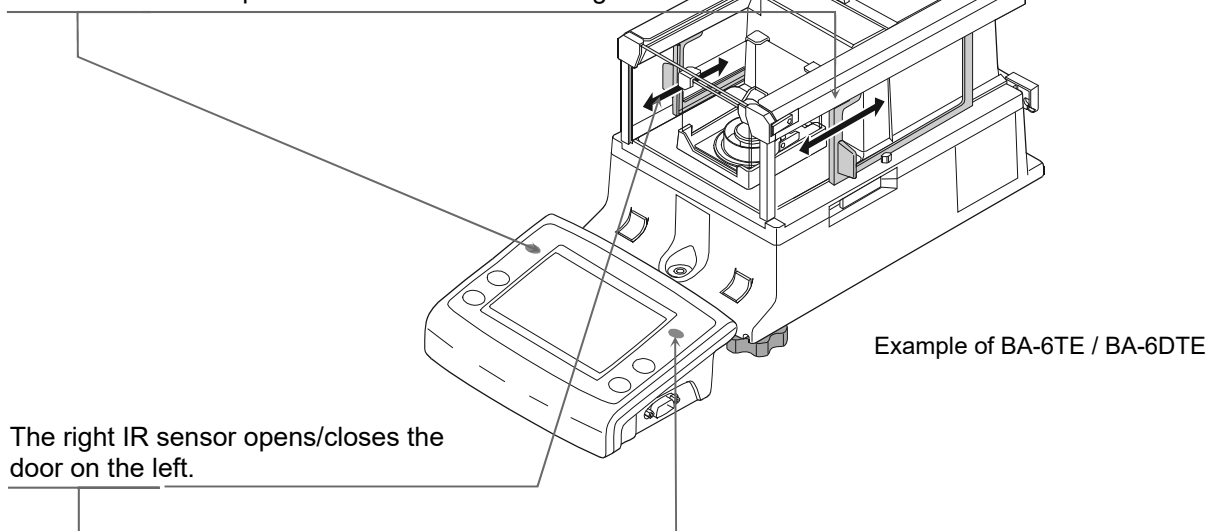

The right IR sensor opens/closes the door on the left.

6. Check Function

The check function performs daily inspections and regular inspections.

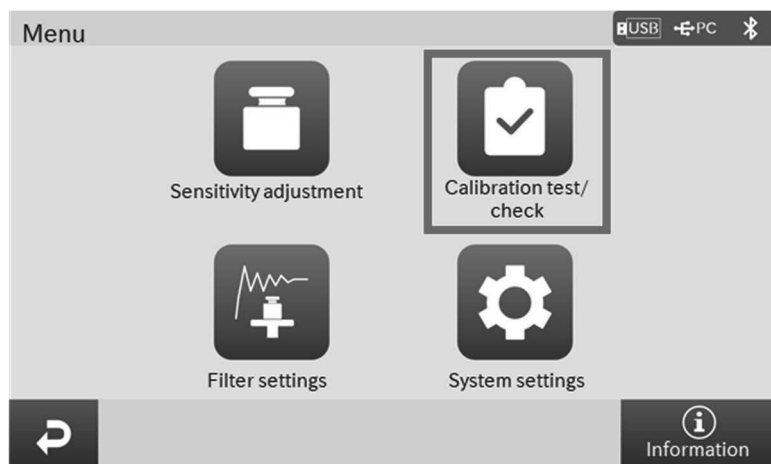

Additionally, whether or not the balance's performance is being exhibited can be easily checked by checking the repeatability with the internal mass.

The check function can be selected from the menu screen. For details, refer to the separate instruction manual listed in "1.1. Detailed Manuals".

7. Sensitivity Adjustment / Calibration Test

7.1. Automatic sensitivity adjustment

The sensitivity of the balance is automatically adjusted using the internal mass according to ambient temperature change, set time, or interval time. For details, refer to the separate instruction manual listed in “1.1. Detailed Manuals”.

7.2. Sensitivity adjustment using the internal mass

The sensitivity adjustment / calibration test screen is displayed with the  button on the weighing screen.

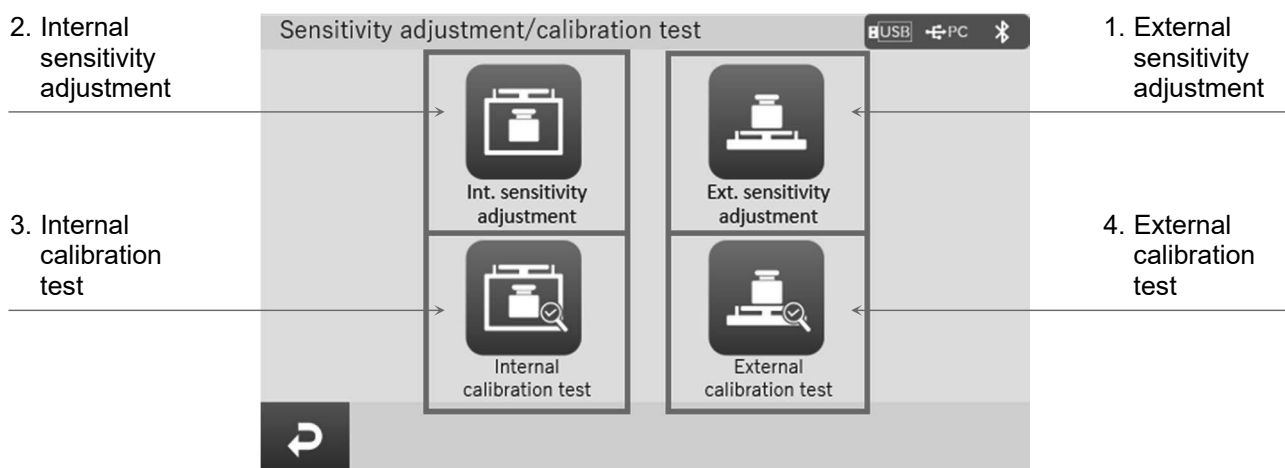

	Name	Description
1	External sensitivity adjustment	Your external calibration weight is used to adjust the balance. Instructions are displayed on the screen for how to adjust the sensitivity.
2	Internal sensitivity adjustment	The internal mass is used to automatically adjust the balance.
3	Internal calibration test	The internal mass is used to check the accuracy of weighing, and the result is output. Note that the balance is not adjusted.
4	External calibration test	Your external calibration weight is used to check the accuracy of weighing, and the result is output. Note that the balance is not adjusted.

Do not allow vibration or drafts to affect the balance during sensitivity adjustment / calibration test. For details, refer to the separate instruction manual listed in “1.1. Detailed Manuals”.

8. Typical Errors (Error Codes)

Display	Error code	Description and possible countermeasure
Error 1	EC, E11	Stability error Weighing value is unstable and "zero display", "sensitivity adjustment", "calibration test", etc. cannot be executed. Check around the pan. Refer to the separate instruction manual listed in "1.1. Detailed Manuals". Improve the environment of the installation location (vibration, drafts, static electricity, etc.).
Error 2		Out of the setting range The value to be set exceeds the setting range. Set again within the setting range.
Error 3		Malfunction of the internal memory element of the balance If this error continues to be displayed, repair is necessary. Please contact your local dealer for repair.
Error 6	EC, E16	Internal mass error Applying the internal mass does not yield a change in the mass value as specified. Confirm that there is nothing on the pan and perform the operation from the beginning.
Error 7	EC, E17	Internal mass error The internal mass application mechanism does not function properly. Perform the operation from the beginning.
Error 8		Abnormality in the internal memory data of the balance If this error continues to be displayed, repair is necessary. Please contact your local dealer for repair.
Error 9		Abnormality in the internal memory data of the balance If this error continues to be displayed, repair is necessary. Please contact your local dealer for repair.
Con Err		Weighing unit error Data from the weighing unit has not been received. Check the connection between the weighing unit and the display unit, and turn the power off and then on again.
door Err		Breeze break unit error Communication with the breeze break is not possible. Reconnect the cable between the breeze break unit and the weighing unit.
S/N Error		Serial number error The serial numbers of the weighing unit and the display unit do not match. Reconnect with the correct combination.
CAL E	EC, E20	Calibration weight error (Positive value) The calibration weight is too heavy. Check around the pan. Check the calibration mass value.
-CAL E	EC, E21	Calibration weight error (Negative value) The calibration weight is too light. Check around the pan. Check the calibration mass value
Weighing display E		Overload error A sample beyond the balance weighing capacity has been placed on the pan. Remove the object from the pan.

Display	Error code	Description and possible countermeasure
Weighing display -E		Weighing pan error The mass value is too light. Check that the weighing pan is installed correctly. Set the weighing pan correctly. Calibrate the balance.
rtc PF		Clock battery error The clock backup battery has been depleted. Set the time and date. Even if the clock backup battery is depleted, the clock and calendar function works normally as long as the balance is powered with the AC adapter. If this error appears frequently, contact your local dealer.
LoWVoLt		Power supply voltage fault The voltage supplied from the AC adapter is abnormal. Please check if the problem is the AC adapter supplied with the balance.
SD Error MW Error		Repeatability error With the minimum weighing warning function, the standard deviation (SD) of repeatability exceeded 50 digits. Review the installation environment of the balance. For details, refer to the separate instruction manual listed in "1.1. Detailed Manuals". "SD Error" appears in repeatability display. "MW Error" appears in minimum weighing value (reference value).
	EC, E00	Communications error A protocol error occurred in communications. Check the format, baud rate, and parity.
	EC, E01	Undefined command error An undefined command was found. Check the transmitted command.
	EC, E02	Not ready The received command cannot be executed: (e.g.) Q command was received when not in weighing mode. (e.g.) Q command was received while rezeroing. Adjust the delay time to transmit a command.
	EC, E03	Timeout error With the command timeout setting, there was a wait time of approximately 1 second or more while receiving command characters. Check the communication.
	EC, E04	Character length error The number of characters in the received command has exceeded the limit. Check the command to transmit.
	EC, E06	Format error The description of the received command is incorrect: (e.g.) The number of digits of numerical values is incorrect. (e.g.) There are alphabet characters among the numerical values. Check the transmitted command.
	EC, E07	Parameter setting error The value of the received command has exceeded the allowed value. Check the setting range of the numerical value of the command.

9. Ionizer (AX-ION-25)

The AX-ION-25 ionizer removes static electricity by irradiating the target object with positive or negative ions, which are generated from four discharge electrodes by DC corona discharge. Ordinarily, insulators such as powders, filters, and weighing paper tend to be charged when the humidity is 45% RH or less, and an error of a few milligrams may occur during weighing. By removing static from the weighing object with the ionizer, it is possible to eliminate the error in the weighing value due to charging, and correct weighing can be performed. For details, refer to the separate instruction manual in "1.1. Detailed Manuals".

9.1. Using the Ionizer

- Step 1. Make sure that the AC adapter of the balance is not connected, and then connect the balance and the ionizer (as noted in "2. Assembly and Installation").
- Step 2. Connect the AC adapter, plug it in, and then turn on the power. The power lamp of the ionizer lights up.
- Step 3. Place the target object within the effective range of static elimination.
- Step 4. Hold your hand over the IR sensor (touchless infrared proximity sensor) on the front of the ionizer to start static elimination. The ION lamp indicating that static elimination is in progress lights up.
- Step 5. Refer to the figure below for the effective range of static elimination, and perform static elimination. At factory setting, when 3 seconds have passed from the start of static elimination, the ION lamp indicating that static elimination is in progress turns off and static elimination stops.

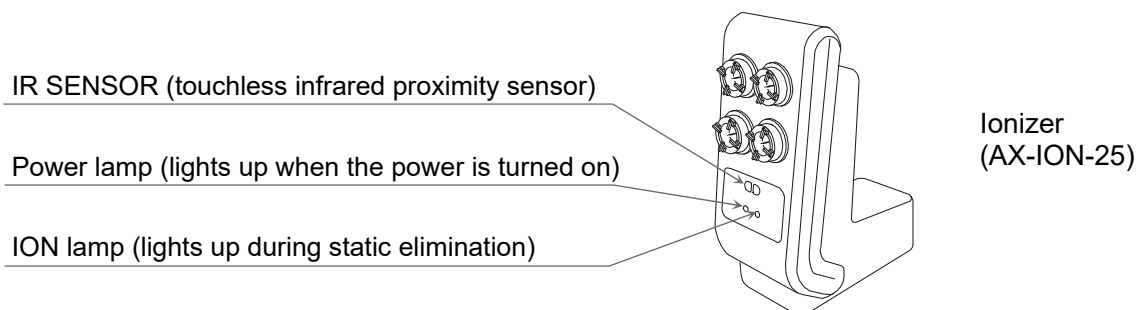

Effective range of static elimination

Top view

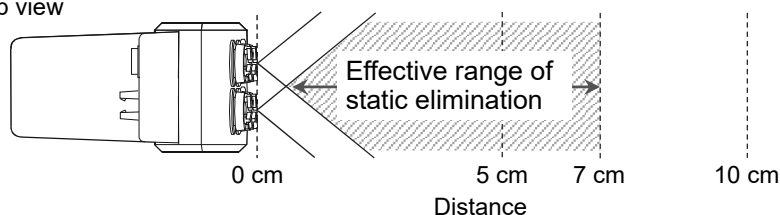

Side view

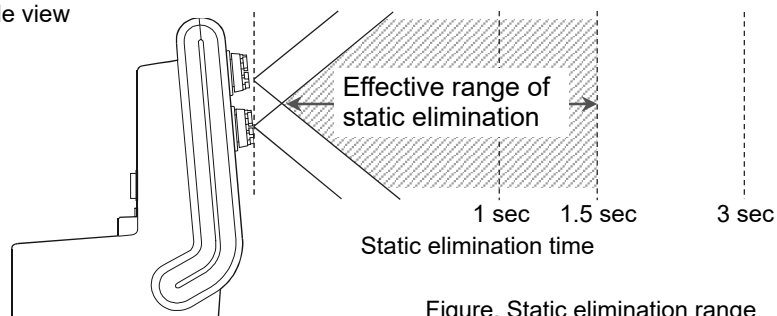

Figure. Static elimination range

10. Specifications

	BA-6TE	BA-6DTE
Weighing capacity	6.2 g	6.2 g
		2.1 g
Maximum display	6.200084 g	6.20008 g
		2.100009 g
Readability	0.001 mg	0.01 mg
		0.001 mg
Repeatability (Standard deviation)	0.0010 mg (1 g) 0.0030 mg (6 g)	0.01 mg (6 g)
		0.0025 mg (1 g)
Linearity	±0.010 mg	±0.02 mg
		±0.010 mg
Display	5-inch WVGA TFT LCD color display	
Operation	Touchscreen and key switches	
Communication	RS-232C (printer, PLC, etc.) USB type A (USB drive, for data storage), USB type B (PC) LAN (TCP/IP), Stereo jack (external switch), Bluetooth (PC, etc.) *	

	BA-225TE	BA-225DTE	BA-125DTE
Weighing capacity	220 g	220 g	120 g
		51 g	51 g
Maximum display	220.00084 g	220.0008 g	120.0008 g
		51.00009 g	51.00009 g
Readability	0.01 mg	0.1 mg	0.1 mg
		0.01 mg	0.01 mg
Repeatability (Standard deviation)	0.015 mg (50 g) 0.03 mg (200 g)	0.1 mg (200 g)	0.1 mg (100 g)
		0.025 mg (50 g)	0.030 mg (50 g)
Linearity	±0.15 mg	±0.20 mg	±0.20 mg
Display	5-inch WVGA TFT LCD color display		
Operation	Touchscreen and key switches		
Communication	RS-232C (printer, PLC, etc.) USB type A (USB drive, for data storage), USB type B (PC) LAN (TCP/IP), Stereo jack (external switch), Bluetooth (PC, etc.) *		

* Bluetooth® communication capability is disabled for regions where the balance is not certified as being compliant with local laws regarding use of Bluetooth® communication.

11. Compliance

11.1. Compliance with FCC Rules

This device contains transmitter module FCC ID: RYYEYSHCN

This device complies with Part 15 of the FCC rules. Operation is subject to the following two conditions: (1) this device may not cause harmful interference, and (2) this device must accept any interference received, including interference that may cause undesired operation.

(FCC = Federal Communications Commission in the U.S.A.)

FCC warning

Changes or modification not expressly approved by the party responsible for compliance could void the user's authority to operate the equipment.

Note: This equipment has been tested and found to comply with the limits for a class A digital device, pursuant to part 15 of the FCC rules. These limits are designed to provide reasonable protection against harmful interference when the equipment is operated in a commercial environment. This equipment generates, uses, and can radiate radio frequency energy and, if not installed and used in accordance with the instruction manual, may cause harmful interference to radio communications. Operation of this equipment in a residential area is likely to cause harmful interference in which case the user will be required to correct the interference at his / her own expense.

11.2. IC

IC RADIATION EXPOSURE STATEMENT FOR CANADA

This device complies with Industry Canada license-exempt RSS standards. Operation is subject to the following two conditions: (1) this device may not cause interference, and (2) this device must accept any interference, including interference that may cause undesired operation of the device.

This device contains transmitter module IC: 4389B-EYSHCN.



A&D Company, Limited

3-23-14 Higashi-Ikebukuro, Toshima-ku, Tokyo 170-0013, JAPAN
Telephone: [81] (3) 5391-6132 Fax: [81] (3) 5391-1566

A&D ENGINEERING, INC.

1756 Automation Parkway, San Jose, California 95131, U.S.A.
Telephone: [1] (408) 263-5333 Fax: [1] (408) 263-0119

A&D INSTRUMENTS LIMITED

Unit 24/26 Blacklands Way, Abingdon Business Park, Abingdon, Oxfordshire OX14 1DY United Kingdom
Telephone: [44] (1235) 550420 Fax: [44] (1235) 550485

A&D AUSTRALASIA PTY LTD

32 Dew Street, Thebarton, South Australia 5031, AUSTRALIA
Telephone: [61] (8) 8301-8100 Fax: [61] (8) 8352-7409

A&D KOREA Limited

한국에이.엔.디(주)
서울특별시 영등포구 국제금융로6길33 (여의도동) 맨하탄빌딩 817 우편 번호 07331
(817, Manhattan Bldg., 33. Gukjegeumyung-ro 6-gil, Yeongdeungpo-gu, Seoul, 07331 Korea)
전화: [82] (2) 780-4101 팩스: [82] (2) 782-4264

ООО A&D RUS

ООО "ЭЙ энд ДИ РУС"
121357, Российская Федерация, г.Москва, ул. Верейская, дом 17
(Business-Center "Vereyskaya Plaza-2" 121357, Russian Federation, Moscow, Vereyskaya Street 17)
тел.: [7] (495) 937-33-44 факс: [7] (495) 937-55-66

A&D INSTRUMENTS INDIA PRIVATE LIMITED

ऐ&डी इन्स्ट्रूमेन्ट्स इण्डिया प्रा० लिमिटेड
509, उद्योग विहार , फेस -5, गुडगांव - 122016, हरियाणा , भारत
(509, Udyog Vihar, Phase-V, Gurgaon - 122 016, Haryana, India)
फोन : 91-124-4715555 फैक्स : 91-124-4715599