

INSTRUCTION MANUAL

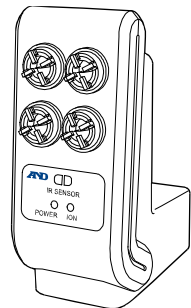

© 2020 A&D Company Ltd. All rights reserved.

- No part of this publication may be reproduced, transmitted, transcribed, or translated into any language in any form by any means without the written permission of A&D Company Ltd.
- The contents of this manual and the specifications of the instrument covered by this manual are subject to change for improvement without notice.



1WMPD4004252A

1. Introduction

This manual describes outline of the ionizer (AX-ION-25) and how to use it correctly. Please thoroughly read this manual before using the AX-ION-25 and keep it at hand for future reference.

2. Features

This ionizer eliminate static electricity on the weighing sample by generating bipolar ions from 4 electrode needles.

- The ionizer can eliminate static electricity on a charged weighing sample without breeze. A weighing error can be reduced.
- AC adaptor is needless because power of the ionizer is supplied from main unit of the balance.
- This ionizer can be controlled by using built-in IR sensor, option IR switch (AX-IR-SWITCH).
- Electrode unit is removable. A unit can be cleaned and replaced.

Static electricity

In general, nonconductors such as powder, filter, medicine wrapping paper, plastic etc. easily become electrostatically charged when the ambient humidity is less than 45 %RH. The static electricity may cause weighing error of approximately few mg at weighing. This ionizer can perform static elimination effectively.

3. Cautions before Use

Read the following cautions for safety use of the ionizer.

- Operate the ionizer gently because of precision instrument.
- Do not install the following place. Place getting water, vibration, shock, direct sunshine. Dusty place, air including salt or corrosive gas, a place in flammable gas.
- Do not turn on power of the ionizer until the installation is finished. The switch to turn off is not equipped in the ionizer.

4. Specifications

Ion generation method	Direct corona discharge
Effective range of static electricity elimination	Approximately 7 cm or shorter from the electrode needle
Operation temperature and humidity	5 to 40 °C, 85% RH or less (no condensation)
Discharge electrode needle	Tungsten (with a life of approx. 10,000 hours)
Dimensions	68(W)×128(D)×163(H) mm
Mass	Approximately 370 g

5. Part Names

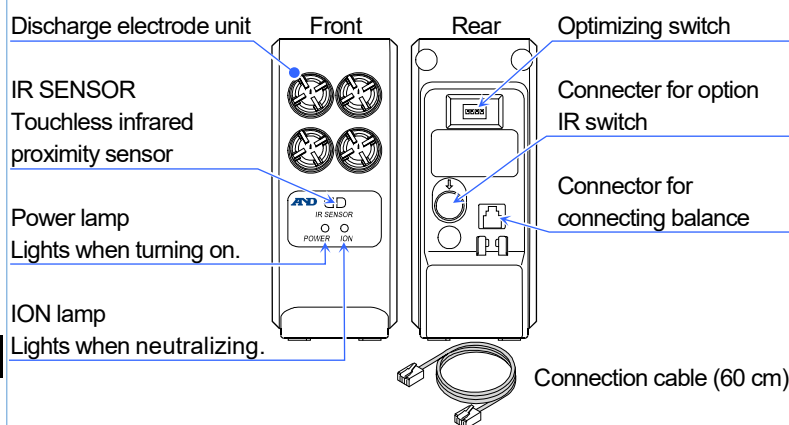

6. How to Use

6.1. Connecting to the balance

Caution Disconnect the AC adapter before installing the ionizer to the balance.

- Connect the ionizer to the balance using connection cable.
- Connecting the AC adapter of the balance, the power lamp lights up.

- The ionizer supports only BA series as of May 2021. Refer the following homepage for the updated information. <https://www.aandd.jp>

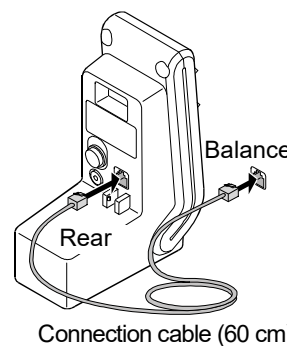

6.2. Static elimination

- Put the weighing sample into the effective range shown in the figure 1.
- Responding the IR sensor (touchless infrared proximity sensor) on the front panel, option IR switch, the ION lamp lights up and static elimination starts.
- Perform static elimination referring to the figure 1. Static elimination process stops automatically in 3 seconds and ION lamp turns off for factory setting. Referring to "7. Optimizing the ionizer", optimize static elimination method and discharging time if the distance between electrode needles and weighing sample is 10 cm or father.

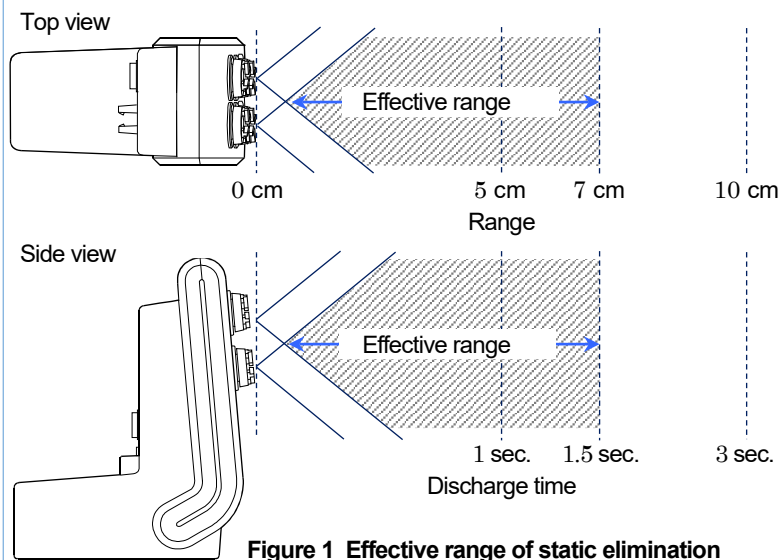

6.3. Connecting Options

Caution Remove power supply cable when connecting peripherals to the ionizer.

Static elimination process can be controlled by using option IR switch instead of the built-in IR sensor. The ionizer can not send PRINT and RE-ZERO command to the balance by using option IR switch

Option IR switch

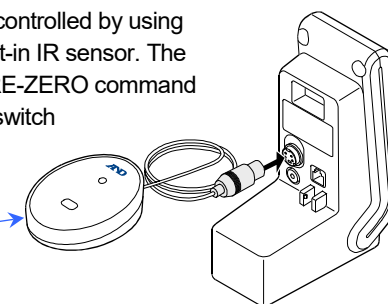

7. Optimizing the Ionizer

Static elimination method can be optimized by using switches on the rear. Refer to the following table for functions of switches. Change the settings of the switch 1 and switch 2 eliminating static electricity outside the effective range shown as in the figure 1.

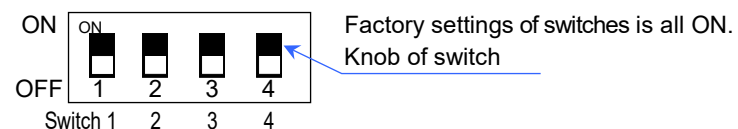

Factory settings of switches is all ON (Upper side). It means static elimination method is "Timer mode", "Discharging time" is 3 seconds, "Built-in IR sensor" and "Buzzer" is available.

Table 1 Functions of the optimizing switches

Switch No. / Item	State of switch	Descriptions
Switch 1 Static elimination method	ON Upper side	Timer mode #1
	OFF Lower side	Manual mode #2
Switch 2 Discharging time #3	ON Upper side	3 seconds
	OFF Lower side	10 seconds
Switch 3 Built-in IR sensor	ON Upper side	Available
	OFF Lower side	Not Available
Switch 4 Buzzer #4	ON Upper side	Available
	OFF Lower side	Not Available

#1 When switch 1 is selected "Timer mode", static elimination is performed for "Discharging time" set by switch 2.

#2 Once static elimination has started, it continues until built-in IR sensor or option IR switch responds again when switch 1 is selected

"Manual mode". "Manual mode" does not stop static elimination automatically.

#3 The setting of the switch 2 is effective when switch 1 is selected "Timer mode".

#4 Buzzer sounds at power on and responding the built-in IR sensor or option IR switch.

8. Maintenance

Caution Do not touch the discharge electrode unit to avoid electric shock during neutralization.

- When the ionizer is used continuously, discharge electrode needle and around may get dirty and neutralization performance may become weak. Clean the electrode needle periodically using cotton swabs to maintain performance.
- When the electrode needle wears out and static elimination performance does not refresh by cleaning, replace all of discharge electrode units to new ones of option. Life time of discharge electrode unit is approximately 10000 hours.

Procedure of replacement

- Remove the connection cable to turn off the ionizer.
- Rotate a discharge electrode unit to 45 degree counterclockwise. Remove it.
- Insert new units and rotate them to 45 degree clockwise.

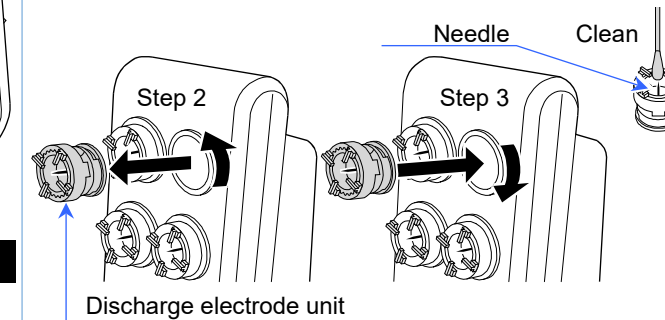

9. Options

Discharge electrode unit AX-BM-NEEDLESET (A set is 4 units.)

- Replacement electrode units.
- Replace all of 4 units with new ones.
- Refer to the "8. Maintenance" for replacement procedure.

IR switch AX-IR-SWITCH

- Touchless infrared proximity sensor.
- Refer to the "6.3. Connecting Options" how to connect it.
- Static elimination operation can be controlled by moving hand over the "SENSOR".

