

**AP Amplifier Series**

**RA2000 Series  
Amplifier Units**

**INSTRUCTION MANUAL**



1WMPD4003505



AP Amplifier Series

RA2000 Series  
Amplifier Units

Instruction Manual





# INTRODUCTION

Thank you very much for purchasing the Amplifier Units, Omniace RA2000 Series (RA2300MK II , 2800A). Prior to using the units, please carefully read the instruction manual so that you can correctly use the amplifier units. This instruction manual provides operating instruction information on the following amplifier units:

2ch High-Resolution DC Amp Unit	TC-DC Amp Unit
2ch FFT Amp Unit	F/V Converter Unit
2ch High-Speed DC Amp Unit	2ch Vibration & RMS Amp Unit
2ch AC Strain Amp Unit	2ch DC Strain Amp Unit
Event Amp Unit	2ch Zero Suppression Amp Unit
2ch TC-DC Amp Unit	

This instruction manual is to provide information that is necessary for you to safely and correctly operate the amplifier units, Omniace RA2000 Series. Please always place this instruction manual together with the amplifier units whenever you use the units, so that you can access and refer to the manual at any time.

This instruction manual involves operating instruction information, advice and suggestions on the use of the amplifier units, Omniace RA2000 Series, as well as their basic functions. For operating instruction information other than that described herein, please refer to the other instruction manuals attached hereto.

If you have questions on any descriptions of this instruction manual, please contact marketing/sales personnel of A&D.

The separate-volume instruction manuals related to amps are as follows:

Correspondence Product	Titles of instruction manuals
RA2300MK II	Instruction Manual MAINFRAME For RA2300MK II
RA2800A	Instruction Manual MAINFRAME For RA2800A

## ■ Before Using Amplifier Units:

- **Instructions for unpacking**

Please unpack the package, only after the temperature of the content of the package becomes almost the same as that of the unpacking room or environment. This is because, particularly when it is cold in winter, dew condensation would occur on the surface of the equipment, thus creating a possibility of equipment failure, if you unpack the package in a warm environment right after bringing it from the open air.

- **Confirmation of contents**

A&D is always taking the utmost care of providing customers with flawless products, including through the use of its inspection system, etc. However, please confirm that no defects can be found in appearance of the equipment upon unpacking the package. Also, please confirm that you have had all accessories in place. In addition, please check the amplifier units as to the specifications of the equipment. If, at the worst, you find any defects or lack of contents, please contact your dealer.

- **Procedure of changing amplifier units**

Please refer to "Chapter 5. Procedure for Changing Amplifier Units", when you want to change your amplifier units.

## Notice

- If anything unusual happens during the use of the equipment, immediately switch off the mainframe of the Omniace RA2000 Series and disconnect it from the power source.
- If you cannot find the cause of the problem, contact our sales representative.
- Contents of this instruction manual are subject to change without prior notice.
- Reprinting or reproduction of this manual, in whole or in part, without permission is prohibited.
- A&D has made every effort to attain the completeness in contents of this manual. Please feel free to contact our sales representative regarding any errors, omissions, questions or suggestions, if you find one.

## ■ Safety Considerations and Precautions - Warning and Caution

### ● Notes for safely using Amplifier Units

While the amplifier units have been manufactured by putting the highest priority on safety aspects, errors in handling or operating the equipment on the part of customers could lead to serious accidents. Please read carefully and comprehend thoroughly the Instruction Manual before using the amplifier units, so that such accidents can be avoided.

Please be sure to observe the descriptions hereunder when using the equipment. No warranties or assurances will be provided or implied for any injuries or damages resulting from actions not complying with the handling or operating Warnings, Cautions or alike.

The designations described below are used throughout the instruction manual to secure the safe usage and operation of the amplifier units; the meaning the designations are explained in the following:



If any instructions in WARNING are ignored, the ignorance could lead to one or more of the following:

1. possibility of human deaths or serious injuries
2. high rate of occurrence of minor personal injuries or non-personal physical damages



If any instructions in CAUTION are ignored, the ignorance could lead to one or more of the following:

1. risk of human injuries
2. possibility of non-personal physical injuries not involving human injuries



**WARNING indication labels of amplifier units**

● **Input signal connection and permissible common mode input voltages**

First, confirm that the recorder unit of the Omniace RA2000 Series is correctly and securely grounded through the protective grounding terminal, before connecting the equipment with a device to be measured. Also, be careful so that the input voltage does not exceed the permissible range of common mode input voltage, when you connect an amplifier unit with the measurement equipment. Otherwise, it is very dangerous since your ignorance in these respects could lead to equipment failure. Be sure to use the equipment within the permissible range of common mode input voltage.

Input units	Permissible common mode input voltage
2ch High-Resolution DC Amp Unit 2ch FFT Amp Unit 2ch High-Speed DC Amp Unit Event Amp Unit F/V converter Unit 2ch Vibration & RMS Amp Unit 2ch Zero Suppression Amp unit	<b>±42 VDC (in DC or in AC peak voltage) for units by itself *300 VAC when used with insulated BNC cables (optional item)</b>
2ch AC Strain Amp Unit 2ch DC Strain Amp Unit	<b>300 VAC</b>
2ch TC-DC Amp Unit	<b>±42 V (in DC or in AC peak voltage)</b>
TC-DC Amp Unit	<b>±300 V (in DC or in AC peak voltage)</b>

\*The common mode voltage refers to the voltage commonly applied between the ground and two input terminals (+, -) as illustrated in the figure below. Recorded waveforms may sometimes involve noise components due to degradation of common mode rejection ratio (CMRR), when impulsive common mode voltages like noise are applied.

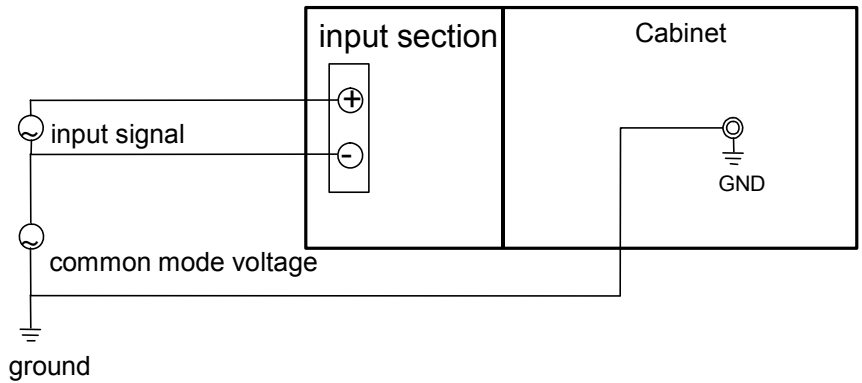

● **Input signal cable**

Use by all means insulated BNC cables (optional item: signal cables 0311-5175, with a BNC connector and test clips, of 2 m long) for input connection, when the equipment is equipped with input terminals of the BNC type.

Be careful not to touch the outer shells of metal type BNC connectors, since they have the negative (-) polarity potential of the signal. You would suffer an electric shock when touching the outer shell; it is very dangerous for you to touch it. Please do not use metal type BNC plugs as they will cause difficulties in mating with insulated BNC sockets.

---

**WARNING**

---

● **Warning against electric shock and permissible input voltage**

Do not touch, by any means, metal portions of the input section, when a high voltage input signal is being applied, to avoid a risk of electric shock.

Also, it is very dangerous to apply an input voltage exceeding the range of permissible input voltages for individual amplifier units, since application of such high voltages would cause equipment failures. Use the equipment within the range of permissible input voltages listed below.

Input units	Permissible input voltages (in DC or in AC peak values)	Range and setting conditions
2ch High-Resolution DC Amp Unit 2ch FFT Amp Unit	<b>±100 V</b>	0.1,0.2,0.5,1,2,5 V-FS (in full scale)
2ch High-Speed DC Amp Unit 2ch Vibration & RMS Amp Unit	<b>±500 V</b>	10,20,50,100,200,500 V-FS (in full scale)
2ch TC-DC Amp Unit TC-DC Amp Unit	<b>±50 V</b>	
F/V converter Unit	<b>±100 V</b>	
2ch DC Strain Amp Unit	<b>±8 V</b>	
2ch Zero Suppression Amp Unit	<b>±100 V</b>	0.1,0.2,0.5,1,2 V-FS (in full scale)
	<b>±500 V</b>	5,10,20,50,100,200,500 V-FS (in full scale)

● **Warning against electric shock and prevention of mainframe damages**

Always keep blank panels inserted/mounted at individual vacant slots for input amplifier units to prevent electric shock and also to prevent the mainframe from potential damages due to foreign matter penetration.

---

**CAUTION**

---

● **CAUTIONS for handling amplifier units**

Observe the CAUTIONS described below when handling amplifier units.

Improper handling of the equipment could lead to operational errors or equipment failures.

- 1) The equipment shall be used only by those who completely know/understand the operating instructions for the amplifier unit as well as the mainframe.
- 2) Storage environment and storage methods of amplifier units:  
 Amplifier units shall be stored in an environment of the temperature between -10 and 70 °C  
 Particularly during summer months, avoid storing them in the direct sunlight or in such places as having a high possibility of extreme temperature rise (e.g., in an enclosed vehicle) for a long period of time.  
 In other aspects, electronic devices used in amplifier units are easily affected by electrostatic discharge.  
 Store amplifier units in places or envelopes processed against electrostatic charge/discharge, paying attention to electrostatic charging phenomena.
- 3) When you want to change amplifier units in the mainframe, switch off the power source of the mainframe and remove power and signal cables from the mainframe by all means, before changing them. The mainframe and amplifier units might be damaged if you change amplifier units with electrical source connected.  
 In addition, be careful not to touch internal electronic parts when changing amplifier units. This is because you could damage the equipment if you touch electronic parts when your body is charged with electrostatic charges. Do not touch any parts other than equipment panels when you change amplifier units, since touching any parts other than panels could lead to equipment failures.
- 4) The amp units are carefully designed so that safety of users can be maintained. However, when measuring high voltages, touching measurement subjects, probes, or output terminals without care may result in electric shock.



- 5) Use the original packing box and crating materials, or the equivalent at the minimum, when you transport amplifier units. In addition, when transporting units or parts after removing them that are incorporated with the recorder unit, cover them with antistatic bag or shock-absorbing sheets to protect them from damage due to drop or chock.
- 6) It is recommended that you regularly calibrate the equipment so that the accuracy of amplifier units can be maintained.  
The high reliability of your measurement can be maintained by regularly calibrating your equipment once a year (service available by payment).

## ■ Warranty Application

A&D is making every effort in maintaining a high quality control level for its products from the design to shipping phases. However, in an unlikely event of finding a symptom of failures, you should check the operational status of the equipment, the status of the electric source voltage and the connection status of various cables, before asking A&D for repair. Consult with our sales representative for request for repair or for regular calibration of the equipment. Please do not forget to inform the equipment type, the serial number and the details of your failure.



The warranty period and the warranty terms are provided in the next section.

## ■ Warranty Provisions

1. Period of warranties: The period of warranties for the product is one (1) year from the time of delivery.
2. Warranties: Failures that occurred during the period of warranties are repaired free of charge in principle. The following cases, however, are subject to your payment of repair charge:
  - (1) damages or failures due to incorrect handling of equipment
  - (2) damages or failures due to fires, earthquakes, traffic accidents or any other acts of God.
  - (3) damages or failures caused by repairs or modification of equipment that are carried by someone other than A&D or any of those who are commissioned by A&D.
  - (4) failures due to use or storage under the environment exceeding the prescribed conditions for the equipment.
  - (5) Regular calibration
  - (6) failures or damages that occurred during transport or transfer of equipment after delivery.
3. Range of warranties: A&D is not responsible to any equipment not manufactured by A&D.

## ■ Designations used in this instruction manual

The following explains the meaning of designations and symbols used in this instruction manual:

designations or symbols	meaning	
 <b>WARNING</b>	If any instructions in WARNING are ignored, the ignorance could lead to one or more of the following: 1. possibility of human deaths or serious injuries 2. high rate of occurrence of minor personal injuries or non-personal physical damages	
 <b>CAUTION</b>	If any instructions in CAUTION are ignored, the ignorance could lead to one or more of the following: 1. risk of human injuries 2. possibility of non-personal physical injuries not involving human injuries	
<b>NOTE</b>	If any instructions in NOTE are ignored, the ignorance could lead to one or more of the following: 1. possibility of mal-function of equipment 2. possibility of deletion or loss of measurement data	
<b>TIPS</b>	Descriptions under TIPS provide information on restriction or limitation for setting or other supplementary information.	
	This sign indicates a page or pages to be referred to.	
this product	The words indicate the recorder unit, Omniace RA2000 Series (RA2300MK II or RA2800A)	
the memory	This indicates the internal memory of the Omniace RA2000 Series. Measured data is stored in "the memory" in the Multi-Recorder mode.	
k (small character) K (capital character)	These are units of expressing numerical values as follows: # The small character k like in "10 kg" indicates 1000. # The capital character K like in "4 Kbytes of data" indicates 1024.	
Individual amplifier units may sometimes be indicated by using the following designations or abbreviations in this instruction manual:		
<b>HRDC</b>	2ch High-Resolution DC Amp Unit	AP11-101
<b>FFT</b>	2ch FFT Amp Unit	AP11-102
<b>HSDC</b>	2ch High-Speed DC Amp Unit	AP11-103
<b>ACST</b>	2ch AC Strain Amp Unit	AP11-104/104A
<b>EV</b>	Event Amp Unit	AP11-105
<b>TCDC</b>	2ch TC-DC Amp Unit	AP11-106/106A
<b>TDC</b>	TC-DC Amp Unit	AP11-107
<b>FV</b>	F/V Converter Unit	AP11-108
<b>RMS</b>	2ch Vibration & RMS Amp Unit	AP11-109
<b>DCST</b>	2ch DC Strain Amp Unit	AP11-110
<b>HRZS</b>	2ch Zero Suppression Amp Unit	AP11-111
Setup Screen	Examples of setup screen are for RA2300MK II . The button positions differ depending on the scrolling directions in the RA2800A, but the functions are the same as those in RA2300MK II .	

# CONTENTS

<b>INTRODUCTION .....</b>	<b>1</b>
<b>■ Before Using Amplifier Units:.....</b>	<b>1</b>
<b>■ Safety Considerations and Precautions - Warning and Caution.....</b>	<b>2</b>
<b>■ Warranty Application .....</b>	<b>5</b>
<b>■ Warranty Provisions.....</b>	<b>5</b>
<b>■ Designations used in this instruction manual.....</b>	<b>6</b>
<b>1. How to Use Amp Unit .....</b>	<b>1-1</b>
<b>1.1. 2ch High-Resolution DC Amp Unit (HRDC, Model AP11-101) .....</b>	<b>1-2</b>
1.1.1. Connection with input signals .....	1-2
1.1.2. How to set 2ch High-Resolution DC Amp Unit (HRDC, Model AP11-101).....	1-4
1.1.3. Specifications of 2ch High-Resolution DC Amp Unit (HRDC, Model AP11-101).....	1-6
1.1.4. External drawings of 2ch High-Resolution DC Amp Unit (HRDC, Model AP11-101) .....	1-7
<b>1.2. 2ch FFT Amp Unit (FFT, Model AP11-102).....</b>	<b>1-8</b>
1.2.1. Connection with input signals .....	1-8
1.2.2. How to set Voltage Measurement Mode of 2ch FFT Amp Unit(FFT, Model AP11-102) ...	1-10
1.2.3. How to set Input Mode (Voltage measurement, Vibration sensor) .....	1-12
1.2.4. How to set Vibration Sensor Mode of 2ch FFT Amp Unit (FFT, Model AP11-102).....	1-13
1.2.5. How to set Vibration Sensor .....	1-14
1.2.6. Specifications of 2ch FFT Amp Unit (FFT, Model AP11-102) .....	1-15
1.2.7. External drawings of 2ch FFT Amp Unit (FFT, Model AP11-102) .....	1-16
<b>1.3. 2ch High-Speed DC Amp Unit(HSDC, Model AP11-103).....</b>	<b>1-17</b>
1.3.1. Connection with input signals .....	1-17
1.3.2. How to set 2ch High-Speed DC Amp Unit (HSDC, Model AP11-103).....	1-19
1.3.3. Specifications of 2ch High-Speed DC Amp Unit (HSDC, Model AP11-103).....	1-21
1.3.4. External drawings of 2ch High-Speed DC Amp Unit (HSDC, Model AP11-103) .....	1-22
<b>1.4. 2ch AC Strain Amp Unit (ACST, Model AP11-104A).....</b>	<b>1-23</b>
1.4.1. Connection with input signals .....	1-23
1.4.2. How to set 2ch AC Strain Amp Unit (ACST, Model AP11-104/104A).....	1-24
1.4.3. Gauge Factor Setup .....	1-26
1.4.4. How to read Measured Value .....	1-27
1.4.5. Synchronization between AC Bridge Power Supply Units (RA23-143).....	1-29
1.4.6. Specifications of 2ch AC Strain Amp Unit (ACST, Model AP11-104/104A) .....	1-31
1.4.7. External drawings of 2ch AC Strain Amp Unit (ACST, Model AP11-104/104A) .....	1-32
<b>1.5. Event Amp Unit (EV, Model AP11-105) .....</b>	<b>1-33</b>
1.5.1. Connection with input signals .....	1-33
1.5.2. How to set Event Amp Unit (EV, Model AP11-105).....	1-34
1.5.3. Adjustment of event waveform .....	1-35
1.5.4. Specifications of Event Amp Unit (EV, Model AP11-105) .....	1-36
1.5.5. External drawings of Event Amp Unit (EV, Model AP11-105) .....	1-37
<b>1.6. 2ch TC·DC Amp Unit (TCDC, Model AP11-106A).....</b>	<b>1-38</b>
1.6.1. Connection with input signals .....	1-38
1.6.2. Kinds of thermocouple and the characteristics .....	1-39
1.6.3. How to set 2ch TC·DC Amp Unit (TCDC, Model AP11-106/106A).....	1-40
1.6.4. Specifications of 2ch TC·DC Amp Unit (TCDC, Model AP11-106/106A) .....	1-42
1.6.5. External drawings of 2ch TC·DC Amp Unit (TCDC, Model AP11-106/106A) .....	1-43
<b>1.7. TC·DC Amp Unit (TDC, Model AP11-107).....</b>	<b>1-44</b>
1.7.1. Connection with input signals .....	1-44
1.7.2. Kinds of thermocouple and the characteristics .....	1-45
1.7.3. How to set TC·DC Amp Unit (TDC, Model AP11-107) .....	1-46
1.7.4. Specifications of TC·DC Amp Unit (TDC, Model AP11-107) .....	1-48

1.7.5. External drawings of TC·DC Amp Unit (TDC, Model AP11-107).....	1-49
<b>1.8. F/V Converter Unit (FV, Model AP11-108) .....</b>	<b>1-50</b>
1.8.1. Connection with input signals .....	1-50
1.8.2. How to set F/V Converter Unit (FV, Model AP11-108) .....	1-51
1.8.3. Ripple ratio and response time .....	1-53
1.8.4. Specifications of F/V Converter Unit (FV, Model AP11-108).....	1-54
1.8.5. External drawings of F/V Converter Unit (FV, Model AP11-108).....	1-55
<b>1.9. 2ch Vibration &amp; RMS Amp Unit (RMS, Model AP11-109) .....</b>	<b>1-56</b>
1.9.1. Connection with input signals .....	1-56
1.9.2. How to set Voltage Measurement Mode of 2ch Vibration & RMS Amp Unit (RMS, Model AP11-109).....	1-58
1.9.3. How to set Input Mode (Voltage measurement/RMS converter/Vibration sensor /Vibration,RMS output) .....	1-60
1.9.4. How to set Vibration Sensor Mode of 2ch Vibration & RMS Amp Unit (RMS, Model AP11-109).....	1-61
1.9.5. How to set Vibration Sensor.....	1-62
1.9.6. Specifications of 2ch Vibration & RMS Amp Unit (RMS, Model AP11-109).....	1-63
1.9.7. External drawings of 2ch Vibration & RMS Amp Unit (RMS, Model AP11-109) .....	1-64
<b>1.10. 2ch DC Strain Amp Unit (DCST, Model AP11-110).....</b>	<b>1-65</b>
1.10.1. Connection with input signals .....	1-65
1.10.2. How to set 2ch DC Strain Amp Unit (DCST, Model AP11-110).....	1-66
1.10.3. Gauge Factor Setup .....	1-68
1.10.4. Specifications of 2ch DC Strain Amp Unit (DCST, Model AP11-110).....	1-69
1.10.5. External drawings of 2ch DC Strain Amp Unit (DCST, Model AP11-110) .....	1-70
<b>1.11. 2ch Zero Suppression Amp Unit (HRZS, Model AP11-111).....</b>	<b>1-71</b>
1.11.1. Connection with input signals .....	1-71
1.11.2. How to set 2ch Zero Suppression Amp Unit (HRZS, Model AP11-111) .....	1-72
1.11.3. Specifications of 2ch Zero Suppression Amp Unit (HRZS, Model AP11-111).....	1-75
1.11.4. External drawings of 2ch Zero Suppression Amp Unit.....	1-76
<b>2. Common Settings for Amp Details Screen .....</b>	<b>2-1</b>
2.1. ON/OFF/GND, Batch, and Initialization.....	2-2
2.2. Initialization of Amp.....	2-4
2.2.1. Initialization in Standard Screen.....	2-4
2.2.2. Amp Details – Initialization in Physical Unit Conversion Screen.....	2-7
2.2.3. Amp Details – Initialization in Expansion Screen .....	2-7
<b>3. Expansion Settings .....</b>	<b>3-1</b>
3.1. Change of Base Line Width of Printing Waveform.....	3-2
<b>4. Physical Unit Conversion - Changing Printing/Display Range .....</b>	<b>4-1</b>
4.1. Overview of Physical Unit Conversion .....	4-2
4.2. How to Convert Physical Units.....	4-3
4.3. Printing/Display Range.....	4-4
<b>5. Procedure for Changing Amplifier Units.....</b>	<b>5-1</b>
5.1. Example of Replacement.....	5-2

# ***1. How to Use Amp Unit***

## 1.1. 2ch High-Resolution DC Amp Unit (HRDC, Model AP11-101)

The 2ch High-Resolution DC Amp Unit converts input signal voltages into digital data of 16 bits with high resolution. The unit has a capability of conversion time of 10  $\mu$ s and incorporates two (2) channels. The two channels are insulated to each other within the unit.

### 1.1.1. Connection with input signals

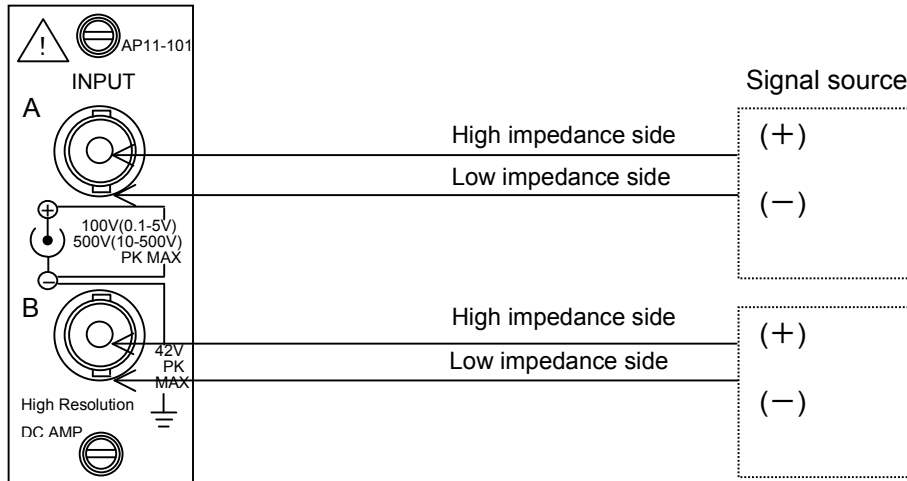

Use by all means insulated BNC cables (optional item: input signal cables 0311-5175, with a BNC connector and test clips, of 2 m long) for input connection.

The outer shells of metal type BNC connectors have the negative (-) polarity potential of the input signal. Therefore, you would suffer an electric shock by touching the outer shell while the cable is connected to a signal source. Thus, note that it is very dangerous for you to touch it.

If you need to use a BNC connector of the metal type due to some unavoidable circumstances, confirm that the common mode input voltage is within the range of  $\pm 42$  V (in DC or in AC peak value) through carrying out appropriate examination of the signal source.

Also, some metal type BNC cables may cause mating problems. Insulated BNC sockets may crack if they are forcibly connected, so please do not use what cannot be mated smoothly.

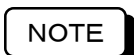

Please pay attention to the following points when you want to record low level signals:

- # Do not use unnecessarily long cables for input connection
- # Use shielded cables for input connection to avoid electrostatic noise

Please keep the signal source impedance as low as possible, i.e., less than 100  $\Omega$ . The lower the signal source impedance is, the higher the quality of measurement record is.

## ■ Input Signals



### Permissible input voltages

If a voltage higher than the rated voltage is input, this unit may be damaged due to internal damage such as component breakdown. Make sure that the input voltage does not exceed the following permissible input voltage for each input range.

Sensitivity ranges (V in FS)	0.1, 0.2, 0.5, 1, 2, 5	10, 20, 50, 100, 200, 500
Permissible input voltages (V)	<b>100 V</b>	<b>500 V</b>



### Input impedance

The input impedance is approximately one (1) MΩ. However, note that the input impedance will be lowered to approximately 15 kΩ, when the input voltage becomes beyond ±8 V for the sensitivity range of 0.1 - 5 V-FS (full-scale) in the DC coupling mode.



### Permissible common mode input voltages (CMV)

Use the insulated BNC cable, an optional item. In this case, confirm that the permissible common mode input voltage is no more than ±300 V in DC or in AC peak value.

**NOTE**

The sample speed must be set at 10μs steps, otherwise the signal waveform cannot be obtained correctly.

Example: 5 μs or 11 μs, etc. makes the waveform distort.

**NOTE**

Use cables with the insulation sheath of no less than 2 kV of withstand voltages.

**NOTE**

Do not apply voltages exceeding the permissible common mode input voltage, since application of such voltages would lead to malfunctions or failures of equipment. Also, note that recorded waveforms may involve noise components due to degradation of common mode rejection ratio (CMRR), when noise-like impulsive common mode voltages are applied.

**NOTE**

Use the equipment through keeping the input voltage within the range of -30V - +30V including the DC component, when the sensitivity range is 0.1 - 5 V-FS in the AC coupling mode.

Note that correct measurement cannot be expected when the input voltage exceeds the voltage range mentioned above.

### 1.1.2. How to set 2ch High-Resolution DC Amp Unit (HRDC, Model AP11-101)

This section covers operations in the Amp Basic screen that appears when the Amp button on the operation panel is pressed and the Amp Details screen that appears when a channel button is pressed.

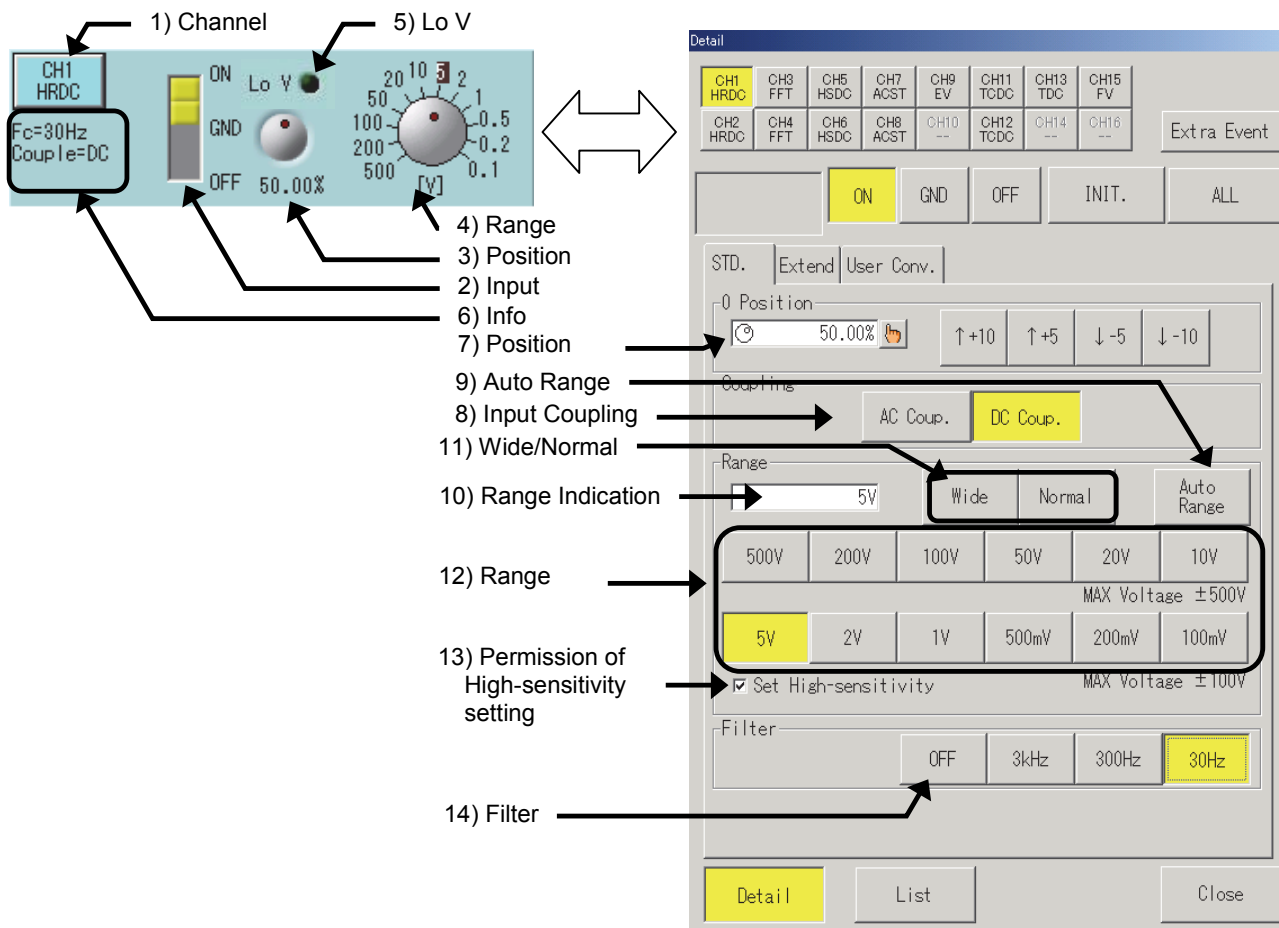

- 1) Basics - Channel  
The channel number, input Amp Unit type, and waveform color are indicated in this portion. Pressing this button displays the Amp Details screen.
- 2) Basics - Input  
Input mode can be selected. Pressing this button permits switching among ON, GND, and OFF.
- 3) Basics - Position  
This button is used to set the zero position. Pressing this button changes the button appearance. The setup can be made with the jog dial.
- 4) Basics - Range  
This button is used to set the range. Pressing this button changes the button appearance. The setup can be made with the jog dial.
- 5) Basics – Lo V  
The LED lights if the high sensitivity range can be permitted.
- 6) Basics - Information  
This portion indicates settings that are unable to be set on this screen. When changing the settings, make the settings in the Amp Details screen.  
Fc: Filter setting  
Couple: Input coupling setting



## 7) Details - Position

The zero position (base line) is set with a button. The zero position means the waveform display position at 0V input (input short). The base line can be set in 5% steps in reference to 100% as the full scale. Also, you can set it with the jog dial by pressing the jog button, or set it from the numeric input window by pressing the window button. And the position change is available through the setup of Physical Unit Conversion or Printing/Display Range. For more information, see Chapter 4. Physical Unit Conversion – Changing Printing/Display Range.

## 8) Details – Input Coupling

The input coupling is set by pressing the AC coupling button or DC coupling button.

**TIPS**

When the AC coupling button is pressed, a capacitor is connected to the input terminal. The DC component can be eliminated, which enables the measurement of alternating voltage.

## 9) Details - Auto range

The range is automatically adjusted to the input signal.

## 10) Details - Range indication

The value of the current display range is displayed.

"#" is displayed when selecting the "Wide" range or changing "Printing / Display Range". After that, if you select the "Normal" range, the setting of "Printing / Display Range" is cleared and "#" disappears.

Also, when checking "Set EU." on the "User Conv." Tab and setting to use physical unit conversion, the full scale converted value will be displayed with \*.

For more information on physical unit conversion and printing / display range setting, see Chapter 4. Physical Unit Conversion - Changing Printing / Display Range.

## 11) Details - Wide/Normal

Wide: Entire measuring range is displayed.

Normal: Half of the measuring range is displayed (Default).

## 12) Details - Range

Range can be directly set.

**TIPS**

When the measurement range is changed, the waveform clip range is cleared to the default value corresponding to the new range.

Example: During expansion of the waveform in the waveform clip range between +40 and -40 at 100 V, if the range is set to 100 V again, the waveform clip range is set to between +50 to -50 as the default. (Enlarged display is cancelled.)



Pay attention to the permissible input voltage when setting the range. See Permissible input voltages in "Input Signals".

## 13) Details - Permission of high sensitivity settings

Settings of the high-sensitive range (5 V to 100 mV) can be prohibited/permitted.

When using the high-sensitivity range, check the check box.

When the high-sensitivity range is not used, prohibition of the high-sensitivity range without checking the box is recommended for safety.

## 14) Details - Filter

This button is used to set the low-pass filter.

1.1.3. Specifications of 2ch High-Resolution DC Amp Unit (HRDC, Model AP11-101)

Number of channels	2 channels (chs)/unit	
Input mode	Unbalanced input (insulation: between channels (ch) inside the unit, between each ch and the cabinet)	
Input coupling modes	AC coupling and DC coupling	
Sensitivity and Accuracy	Input range	0.1, 0.2, 0.5, 1, 2 and 5 V-FS ( $\pm 30$ V or less at AC coupling) 10, 20, 50, 100, 200 and 500 V-FS For all ranges (i.e., $\pm 0.1$ - $\pm 500$ V-FS), Wide-range is available.
	Accuracy	Within $\pm 0.3\%$ -FS <b>* Within <math>\pm 0.8\%</math>-FS for 500 V-FS</b>
Offset accuracy	Within $\pm 0.3\%$ -FS <b>* at 23°C of environment temperature of mainframe operation</b>	
Input impedance	No less than 1 M $\Omega$	
Permissible input voltage	$\pm 500$ V (DC or AC peak value) <b>* <math>\pm 100</math>V (DC or AC peak value) for input ranges of 0.1 - 5 V-FS</b>	
Permissible common mode input voltage (CMV)	$\pm 42$ V (DC or AC peak value) for an amplifier unit only <b>* 300 VAC when an insulated BNC cable (signal cable 0311-5175) is used</b>	
Common mode rejection ratio (CMRR)	No less than 80 dB for frequencies DC - 60 Hz	
Frequency characteristics	For DC coupling: Within the range of +0.5 dB and -3 dB for frequency range of DC - 50 kHz For AC coupling: Within the range of +0.5 dB and -3 dB for frequency range of 0.3 Hz - 50 kHz	
Linearity	Within $\pm 0.1\%$ -FS	
Low pass filter	Two-pole Bessel type: 30Hz, 300Hz, 3kHz and OFF Attenuation characteristics: -12 dB/oct. approximately	
Temperature stability characteristics	Zero point: within $\pm 0.02\%$ -FS /°C Range: within $\pm 0.01\%$ -FS /°C	
A/D conversion characteristics	Resolution	16 bits
	Conversion time	10 $\mu$ s max.
	Conversion method	Serial comparison method
Input connector	Insulated BNC type	
Withstand voltage	1.5 kV AC for one minute between input terminal and ground, and between channels.	
S/N ratio	-52 dB or greater (when set at Wide Range)	
Mass	About 230 g	

1.1.4. External drawings of 2ch High-Resolution DC Amp Unit (HRDC, Model AP11-101)

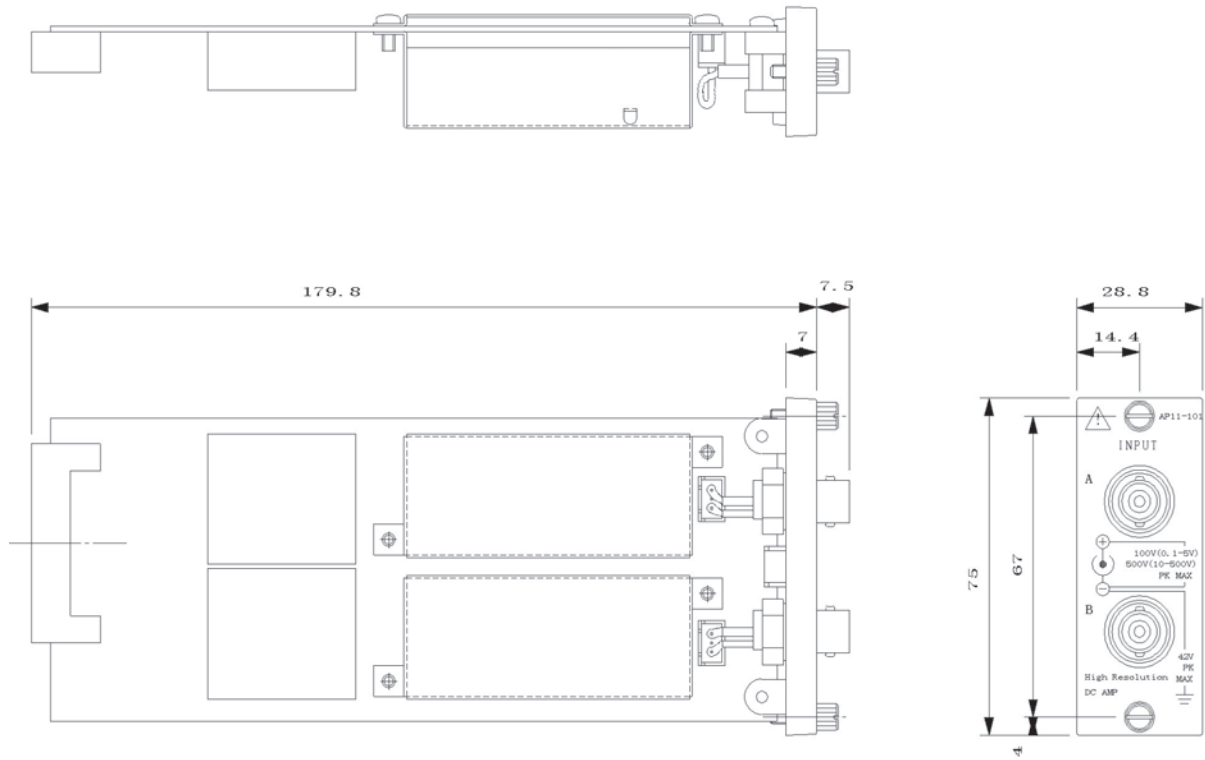

## 1.2. 2ch FFT Amp Unit (FFT, Model AP11-102)

The 2ch FFT Amp Unit is used to FFT-transform output voltages of piezoelectric acceleration sensors built-in the amplifier or other piezoelectric acceleration sensors (used together with charge converters), or other input voltages. They are high-resolution DC amplifier units with anti-aliasing filters built-in. The units have a capability of conversion time of 10  $\mu$ s and incorporate two (2) channels per unit, and the two channels are insulated to each other within the unit.

### 1.2.1. Connection with input signals

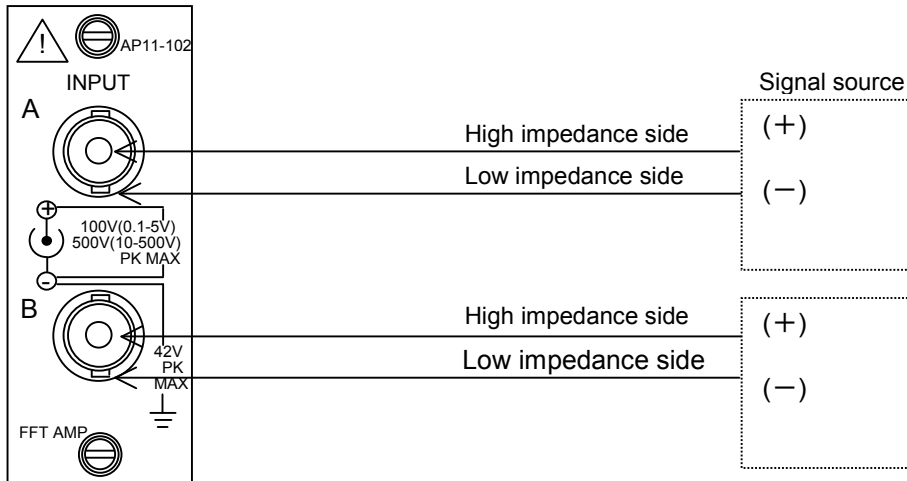

Use by all means insulated BNC cables (optional item: input signal cables 0311-5175, The outer shells of metal type BNC connectors have the negative (-) polarity potential of the input signal. Therefore, you would suffer an electric shock by touching the outer shell while the cable is connected to a signal source. Thus, note that it is very dangerous for you to touch it.

If you need to use a BNC connector of the metal type due to some unavoidable circumstances, confirm that the common mode input voltage is within the range of  $\pm 42$  V (in DC or in AC peak value) through carrying out appropriate examination of the signal source.

Also, some metal type BNC cables may cause mating problems. Insulated BNC sockets may crack if they are forcibly connected, so please do not use what cannot be mated smoothly.

#### NOTE

Please pay attention to the following points when you want to record low level signals:

# Do not use unnecessarily long cables for input connection

# Use shielded cables for input connection to avoid electrostatic noise

#### NOTE

Please keep the signal source impedance as low as possible, i.e., less than 100  $\Omega$ .

The lower the signal source impedance, the higher the quality of measurement records.

## ■ Input Signals



### Permissible input voltages

If a voltage higher than the rated voltage is input, this unit may be damaged due to internal damage such as component breakdown. Make sure that the input voltage does not exceed the following permissible input voltage for each input range.

Sensitivity ranges (V in FS)	0.1, 0.2, 0.5, 1, 2, 5	10, 20, 50, 100, 200, 500
Permissible input voltages (V)	<b>100 V</b>	<b>500 V</b>



### Input impedance

The input impedance is approximately one (1) MΩ. However, note that the input impedance will be lowered to approximately 15 kΩ, when the input voltage becomes beyond ±8 V for the sensitivity range of 0.1 - 5 V-FS (full-scale) in the DC coupling mode.



### Permissible common mode input voltages (CMV)

Use the insulated BNC cable, an optional item. In this case, confirm that the permissible common mode input voltage is no more than ±300 V in DC or in AC peak value

### NOTE

When setting the sampling speed other than 10μs steps (ex. 5μs or 11μs, etc.) or setting the analyzing speed of FFT mode faster than 40 kHz, the signal waveform cannot be obtained correctly. If you execute FFT in that condition, the suspected frequency component is displayed.



In the vibration sensor mode, a constant-current of 2 mA is fed into the load from the input connector of the amplifier unit. (Voltages of more than 18 V can be exhibited at the connector.)

Do not connect any sensors other than the types of sensors that are specified for the use with this amplifier. Otherwise, the sensors may be damaged.

In the vibration mode, do not input voltages. Application of voltages of ±30 V or more at the input would induce amplifier failures.

### NOTE

Use such cables that have the insulation sheath with no less than 2 kV of withstand voltages.

### NOTE

Do not apply voltages exceeding the permissible common mode input voltage, since application of such voltages would lead to malfunctions or failures of equipment. Also, note that recorded waveforms may involve noise components due to degradation of common mode rejection ratio (CMRR), when noise-like impulsive common mode voltages are applied.

### NOTE

Use the equipment through keeping the input voltage within the range of -30V - +30V including the DC component, when the sensitivity range is 0.1 - 5 V-FS in the AC coupling mode.

Note that correct measurement cannot be expected when the input voltage exceeds the voltage range mentioned above.

### 1.2.2. How to set Voltage Measurement Mode of 2ch FFT Amp Unit (FFT, Model AP11-102)

This section covers operations in the Amp Basic screen that appears when the Amp button on the operation panel is pressed and the Amp Details screen that appears when a channel button is pressed.

The following shows the contents of the FFT Amp in the voltage measurement mode. For the vibration sensor mode, see 1.2.3 How to set Input Mode (Voltage Measurement/Vibration Sensor) and switch to the voltage measurement mode.

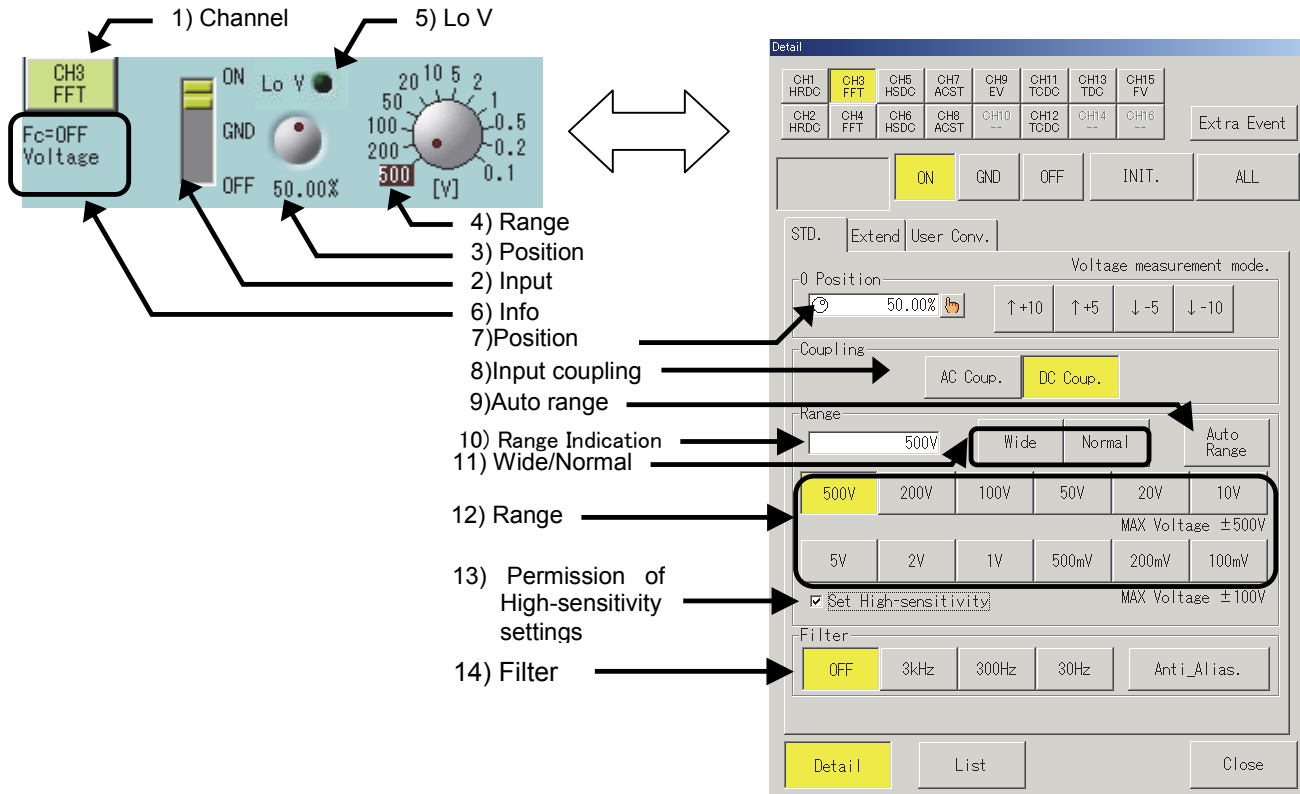

- 1) Basics - Channel  
The channel number, input amp unit type, and waveform color are indicated in this portion. Pressing this button displays the Amp Details screen.
- 2) Basics - Input  
Input mode can be selected. Pressing this button permits switching among ON, GND, and OFF.
- 3) Basics - Position  
This button is used to set the zero position. Pressing this button changes the button appearance. The setup can be made with the jog dial.
- 4) Basics - Range  
This button is used to set the range. Pressing this button changes the button appearance. The setup can be made with the jog dial. The displayed contents are the same as those in Voltage Measurement Mode. That is, the contents are different from those for the vibration measurement mode.
- 5) Basics – Lo V  
The LED lights if the high sensitivity range can be permitted.
- 6) Basics - Information indication  
This portion indicates settings that are unable to be set on this screen. When changing the settings, make the settings in the Amp Details screen.  
Fc: Filter setting  
Measurement mode setting (Voltage/Vibration)

- 7) Details - Position  
The zero position (base line) is set with a button. The zero position means the waveform display position at 0V input (input short). The base line can be set in 5% steps in reference to 100% as the full scale. Also, you can set it with the jog dial by pressing the jog button, or set it from the numeric input window by pressing the window button. And the position change is available through the setup of Physical Unit Conversion or Printing/Display Range. For more information, see Chapter 4. Physical Unit Conversion – Changing Printing/Display Range.
- 8) Details – Input Coupling  
The input coupling is set by pressing the AC coupling button or DC coupling button.

**TIPS**

When the AC coupling button is pressed, a capacitor is connected to the input terminal. The DC component can be eliminated, which enables the measurement of alternating voltage.

- 9) Details - Auto range  
The range is automatically adjusted to the input signal.
- 10) Details - Range indication  
The value of the current display range is displayed.  
"#" is displayed when selecting the "Wide" range or changing "Printing / Display Range". After that, if you select the "Normal" range, the setting of "Printing / Display Range" is cleared and "#" disappears.  
Also, when checking "Set EU." on the "User Conv." Tab and setting to use physical unit conversion, the full scale converted value will be displayed with \*.  
For more information on physical unit conversion and printing / display range setting, see Chapter 4. Physical Unit Conversion - Changing Printing / Display Range.
- 11) Details - Wide/Normal  
Wide: Entire measuring range is displayed.  
Normal: Half of the measuring range is displayed (Default).
- 12) Details - Range  
Range can be directly set.

**TIPS**

When the measurement range is changed, the waveform clip range is cleared to the default value corresponding to the new range.

Example: During expansion of the waveform in the waveform clip range between +40 and -40 at 100 V, if the range is set to 100 V again, the waveform clip range is set to between +50 to -50 as the default. (Enlarged display is cancelled.)



Pay attention to the permissible input voltage when setting the range.

See Permissible input voltages in "Input Signals".

- 13) Details - Permission of high sensitivity setting  
Settings to the high-sensitive range (5 V to 100 mV) can be prohibited/permitted.  
When using the high-sensitivity range, check the check box.  
When the high-sensitivity range is not used, prohibition of the high-sensitivity range without checking the box is recommended for safety.
- 14) Details -Filter  
This button is used to set the low-pass filter.  
In addition, pressing the [Anti-aliasing] button allows filtering corresponding to the acquisition speed and eliminating aliasing.

### 1.2.3. How to set Input Mode (Voltage measurement / Vibration sensor)

The measurement target can be changed by switching the input mode of the FFT Amp. Pressing the Input Mode button in the Expansion tab in the Amp Details screen of the FFT Amp displays the following screen, which allows changing the input mode.

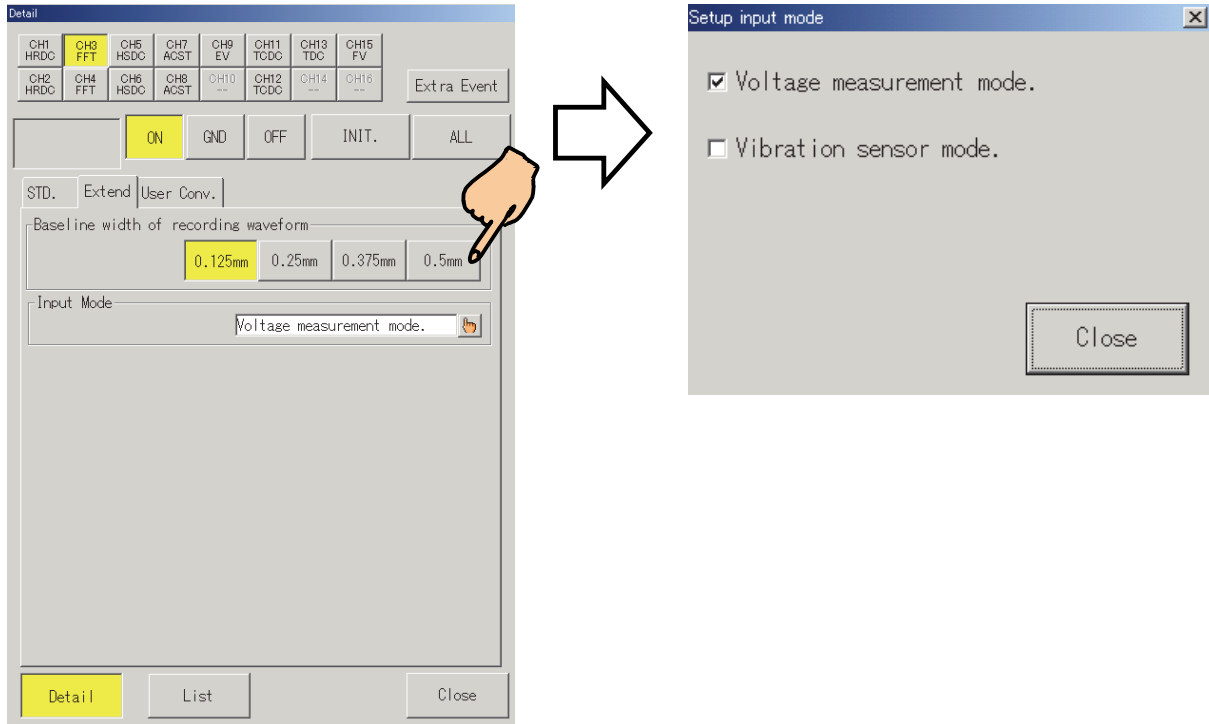

**NOTE** In the vibration sensor mode, a constant-current is required for the sensor. Therefore, if any units other than the vibration sensor are connected to the amp, the signal source may be damaged. Confirm the connection at the amp input port before switching to the vibration sensor mode.



### 1.2.4. How to set Vibration Sensor Mode of 2ch FFT Amp Unit (FFT, Model AP11-102)

This section covers operations in the Amp Basic screen that appears when the Amp button on the operation panel is pressed and the Amp Details screen that appears when a channel button is pressed.

The following shows the contents of the FFT Amp in the vibration sensor mode. For the voltage measurement mode, see 1.2.3 How to set Input Mode (Voltage Measurement/Vibration Sensor) and switch to the vibration sensor mode.

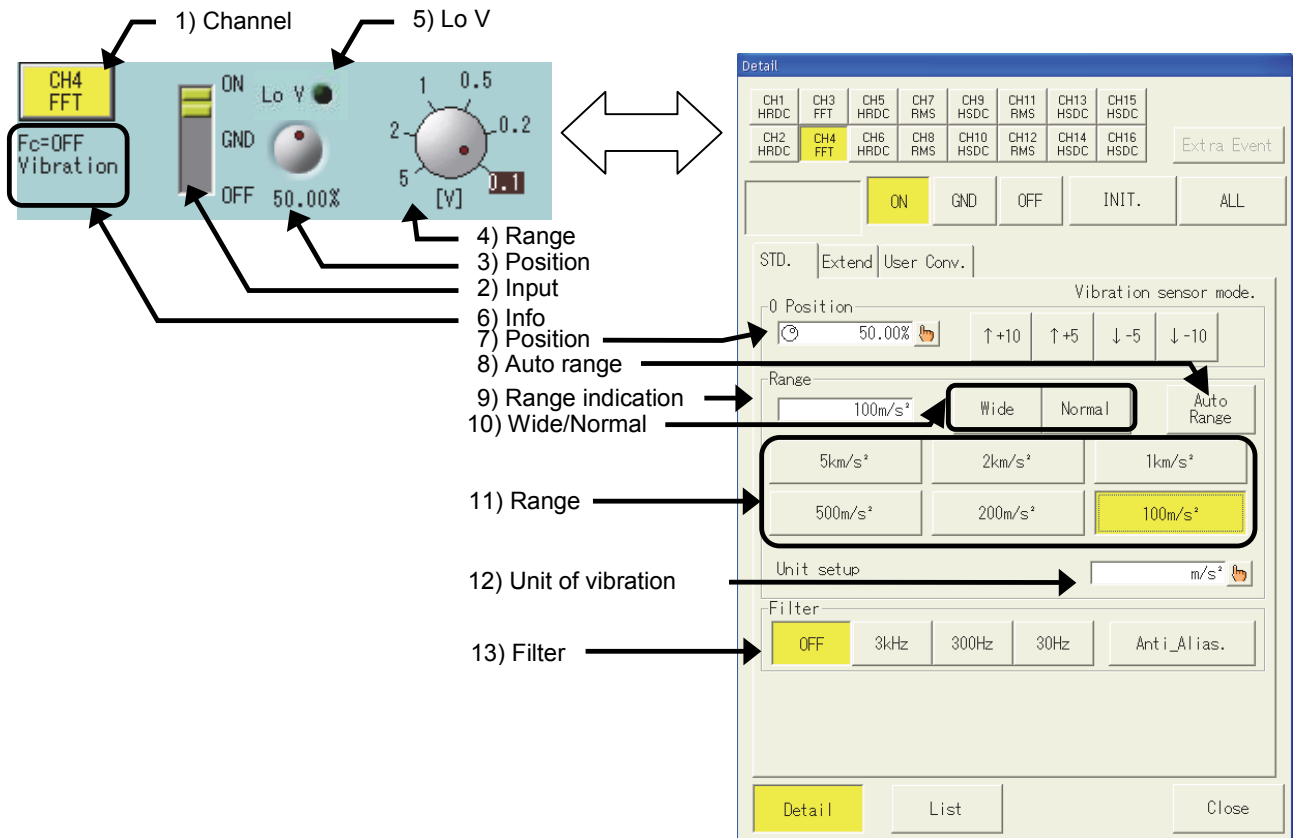

The procedure is the same as those in 1.2.2 How to set Voltage Measurement Mode of 2ch FFT Amp Unit (FFT, Model AP11-102).

Operations of different portions are described hereafter:

- 4) Basics - Range  
The contents are different from those for the voltage measurement mode. However, the operation settings are the same.
- 5) Details - Range  
Range can be directly set. The range values are indicated after calculated with sensor sensitivity, converter sensitivity, and unit of vibration.
- 6) Details - Unit of vibration  
The unit of the vibration system can be selected between units, m/s<sup>2</sup> and G.

#### TIPS

The result from the changed unit is reflected to the range, sensor sensitivity and converter sensitivity. Before starting measurement, confirm the reflected parts.

### 1.2.5. How to set Vibration Sensor

In the vibration sensor mode, the input sensor type can be selected between Built-in Amp sensor and Piezoelectric sensor + Charge converter at the Sensor sensitivity portion in the Expansion tab in the Amp Details screen of the FFT amp.

The settings can be changed by operating buttons in the Sensor Sensitivity portion in the Amp Details screen. Switching the sensor setting changes the setting screen for the sensor sensitivity.

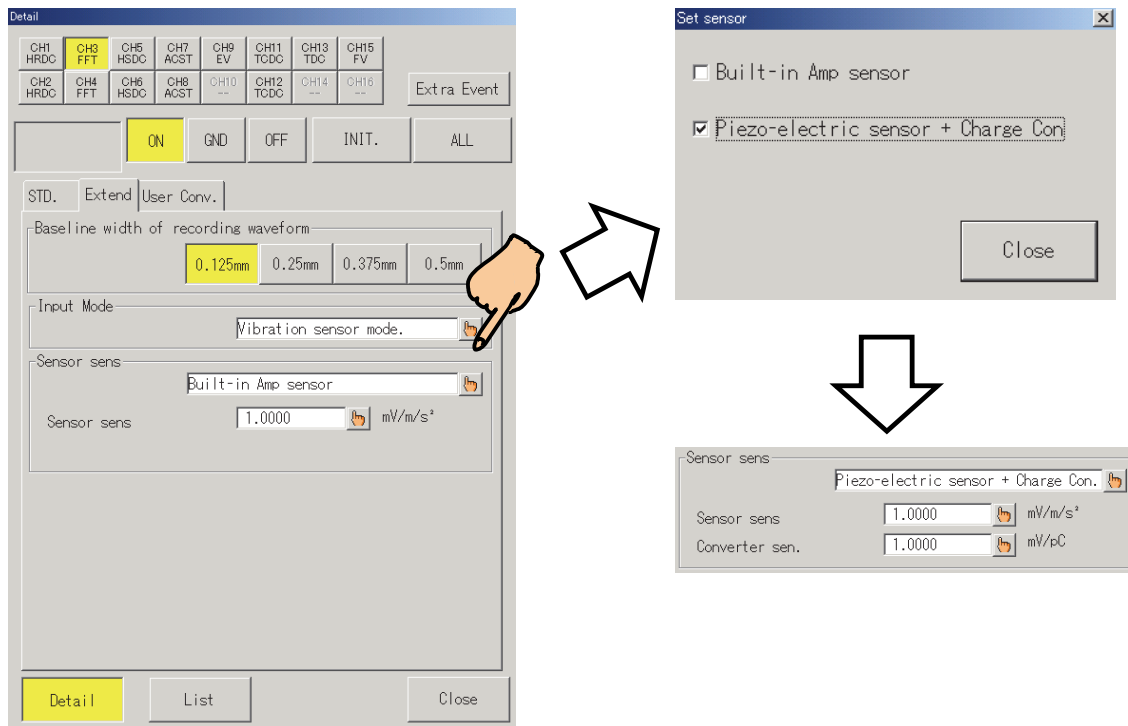

The following tables show the relation between range values by the sensor sensitivity settings.

- **Voltage range for measurement**

The following ranges are available as the voltage range for the vibration measurement:

5 V	2 V	1 V	500 mV	200 mV	100 mV
-----	-----	-----	--------	--------	--------

- **Built-in Amp sensor**

The range values vary depending on the sensor sensitivity settings.

The calculating formula of the vibration range is:

$$\text{Vibration range (m/s}^2\text{)} = \text{Voltage range (V)} \div \text{Sensor sensitivity (V/m/s}^2\text{)}$$

- **Piezoelectric sensor+Charge Converter**

The vibration range values vary depending on the sensor sensitivity and converter sensitivity.

The calculating formula of the vibration range is:

$$\text{Vibration range (m/s}^2\text{)} = \text{Voltage range (V)} \div \left( \text{Sensor sensitivity (pC/m/s}^2\text{)} \times \text{Converter sensitivity (V/pC)} \right)$$

- **Unit of vibration range**

The unit of vibration range is switched between [m/s<sup>2</sup>] and [G] depending on the unit of vibration settings.

## 1.2.6. Specifications of 2ch FFT Amp Unit (FFT, Model AP11-102)

Number of channels	2 channels (chs)/unit	
Input mode	Unbalanced input (Each channel is insulated to each other and also from cabinet.)	
Input coupling modes	AC coupling and DC coupling <b>*AC coupling mode is used when piezoelectric acceleration sensor of the type of amplifier built-in is connected.</b>	
Sensitivity and Accuracy	Input range	For voltage measurement mode: 0.1, 0.2, 0.5, 1, 2 and 5 V-FS ( $\pm 30V$ or less at AC coupling) 10, 20, 50, 100, 200 and 500 V-FS For all ranges (i.e., $\pm 0.1 - \pm 500$ V-FS), Wide-range is available For vibration sensor mode: 5km/s <sup>2</sup> , 2km/s <sup>2</sup> , 1km/s <sup>2</sup> , 500m/s <sup>2</sup> , 200m/s <sup>2</sup> and 100m/s <sup>2</sup> -FS Unit can be changed to G. For every range, fine adjustment capability and wide-scale provisions are provided.
	Accuracy	Within $\pm 0.3\%$ -FS <b>*Within <math>\pm 0.8\%</math>-FS for 500 V-FS</b>
Offset accuracy	Within $\pm 0.3\%$ -FS <b>*at 23°C of environment temperature of mainframe operation</b>	
Input impedance	No less than 1 M $\Omega$	
Permissible input voltage	$\pm 500V$ (DC or AC peak value) <b>*<math>\pm 100V</math> (DC or AC peak value) for input ranges of 0.1 - 5 V-FS</b>	
Permissible common mode input voltage (CMV)	$\pm 42$ V (DC or AC peak value) for an amplifier unit only <b>*300 VAC when an insulated BNC cable (signal cable 0311-5175) is used</b>	
Common mode rejection ratio (CMRR)	No less than 80 dB for frequencies DC - 60 Hz	
Frequency characteristics	For DC coupling: Within the range of +0.5 dB and -3 dB for frequency range of DC - 50 kHz For AC coupling: Within the range of +0.5 dB and -3 dB for frequency range of 0.3 Hz - 50 kHz	
Linearity	Within $\pm 0.1\%$ -FS	
Low pass filter	Two-pole Bessel type: 30Hz, 300Hz, 3kHz and OFF Attenuation characteristics: -12 dB/oct. approximately	
Anti-aliasing filter	10Hz, 20Hz, 50Hz, 100Hz, 200Hz, 500Hz, 1kHz, 2kHz, 5kHz, 10kHz, 20kHz and 40kHz Descending characteristics: -72dB at 1.5fc (typical)	
Temperature stability characteristics	Zero point: within $\pm 0.02\%$ -FS/°C Range: within $\pm 0.01\%$ -FS /°C	
A/D conversion characteristics	Resolution	16 bits
	Conversion time	10 $\mu$ s max.
	Conversion method	serial comparison method
Input connector	Insulated BNC type	
Sensor power supply	2 mA, 18 V or more	
Withstand voltage	1.5 kV AC for one minute between input terminal and ground, and between channels.	
S/N ratio	-46 dB or greater (when set at Wide Range)	
Mass	About 240 g	

1.2.7.External drawings of 2ch FFT Amp Unit (FFT, Model AP11-102)

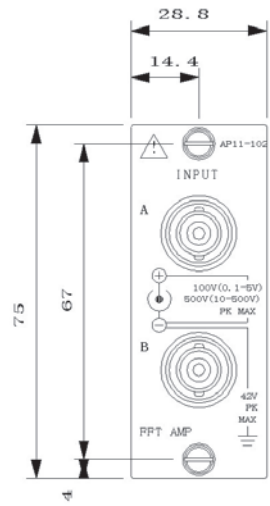
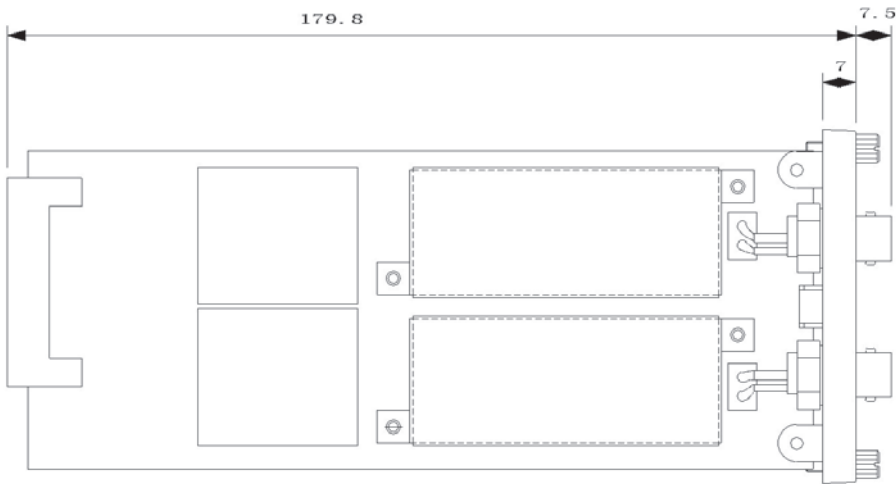
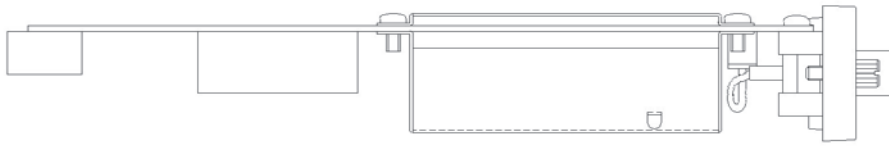

## 1.3. 2ch High-Speed DC Amp Unit (HSDC, Model AP11-103)

The 2ch High-Speed DC Amp Unit converts input analog voltages into digital signals at high speed with a sampling interval of  $1\mu\text{s}$  (i.e., A/D conversion)

The units incorporate two (2) channels per unit and the two channels are insulated to each other within the unit.

### 1.3.1. Connection with input signals

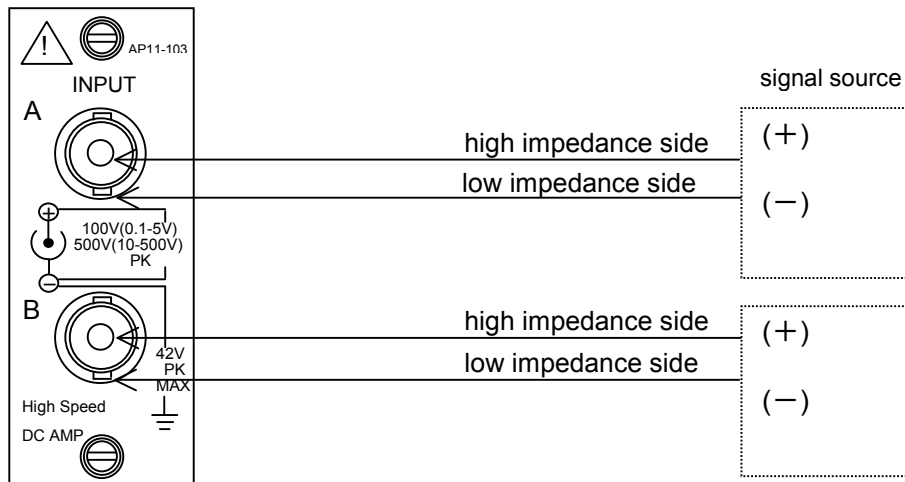

Use by all means insulated BNC cables (optional item: input signal cables 0311-5175, with a BNC connector and test clips, of 2 m in length) for input connection.

The outer shells of metal type BNC connectors have the negative (-) polarity potential of the input signal. Therefore, you would suffer an electric shock by touching the outer shell while the cable is connected to a signal source. Thus, note that it is very dangerous for you to touch it.

If you need to use a BNC connector of the metal type due to some unavoidable circumstances, confirm that the common mode input voltage is within the range of  $\pm 42\text{ V}$  (in DC or in AC peak value) through carrying out appropriate examination of the signal source.

Also, some metal type BNC cables may cause mating problems. Insulation BNC sockets may crack if they are forcibly connected, so please do not use what cannot be mated smoothly.

#### NOTE

Please pay attention to the following points when you want to record low level signals:

- # Do not use unnecessarily long cables for input connection
- # Use shielded cables for input connection to avoid electrostatic noise

#### NOTE

Please keep the signal source impedance as low as possible, i.e., less than  $100\ \Omega$ . The lower the signal source impedance, the higher the quality of measurement records.

## ■ Input Signals



### Permissible input voltages

If a voltage higher than the rated voltage is input, this unit may be damaged due to internal damage such as component breakdown. Make sure that the input voltage does not exceed the following permissible input voltage for each input range.

Sensitivity ranges (V in FS)	0.1, 0.2, 0.5, 1, 2, 5	10, 20, 50, 100, 200, 500
Permissible input voltages (V)	<b>100 V</b>	<b>500 V</b>



### Input impedance

The input impedance is approximately one (1) MΩ. However, note that the input impedance will be lowered to approximately 6 kΩ, when the input voltage becomes beyond ±8 V for the sensitivity range of 0.1 - 5 V-FS (full-scale) in the DC coupling mode.

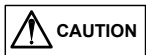

### Permissible common mode input voltages (CMV)

Use the insulated BNC cable, an optional item. In this case, confirm that the permissible common mode input voltage is no more than ±300 V in DC or in AC peak value.



Use cables with the insulation sheath of no less than 2 kV of withstand voltages.



Do not apply voltages exceeding the permissible common mode input voltage, since application of such voltages would lead to malfunctions or failures of equipment. Also, note that recorded waveforms may involve noise components due to degradation of common mode rejection ratio (CMRR), when noise-like impulsive common mode voltages are applied.



Use the equipment through keeping the input voltage within the range of -30V - +30V including the DC component, when the sensitivity range is 0.1 - 5 V-FS in the AC coupling mode.

Note that correct measurement cannot be expected when the input voltage exceeds the voltage range mentioned above.

### 1.3.2. How to set 2ch High-Speed DC Amp Unit (HSDC, Model AP11-103)

This section covers operations in the Amp Basic screen that appears when the Amp button on the operation panel is pressed and the Amp Details screen that appears when a channel button is pressed.

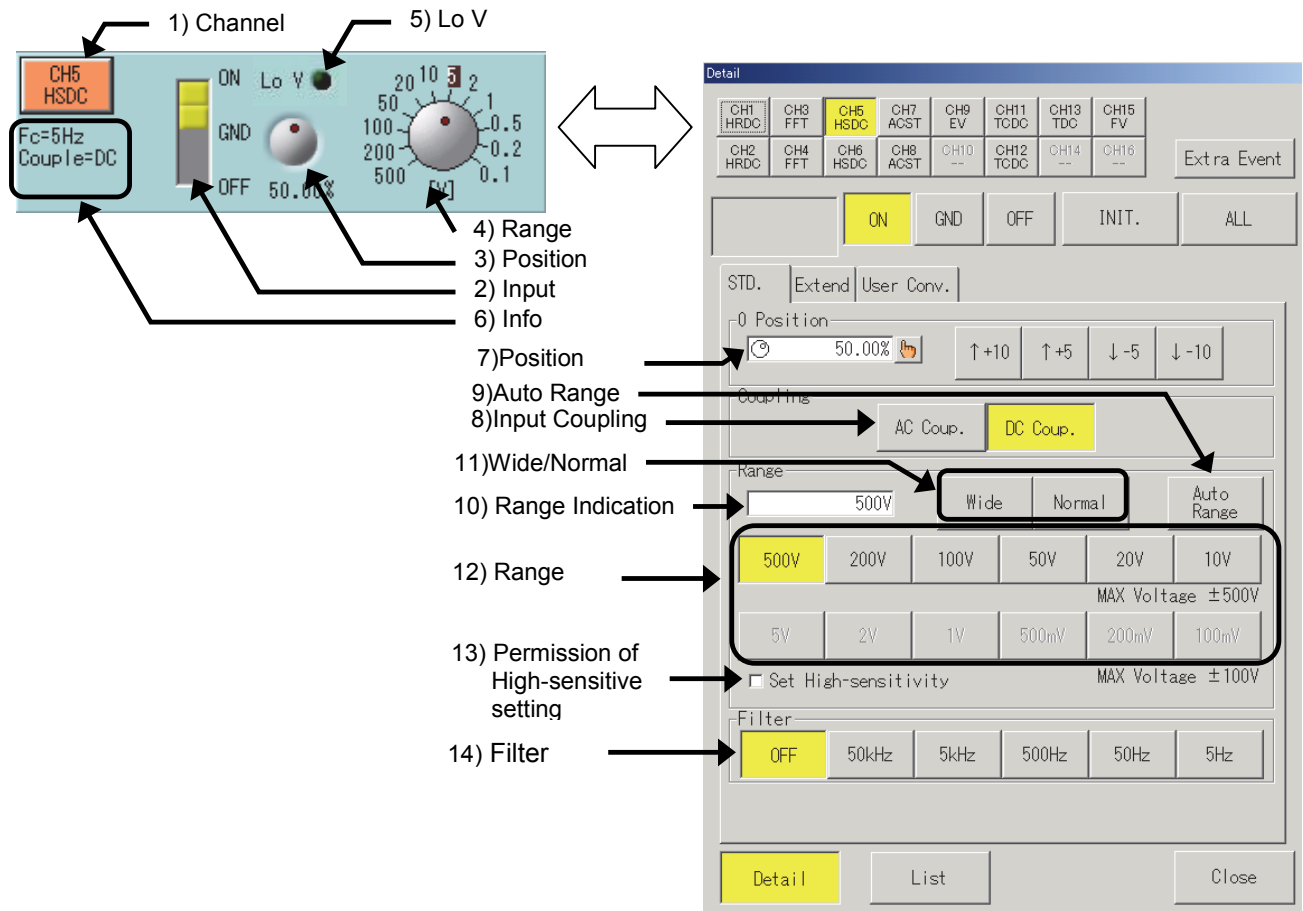

- 1) Basics - Channel  
The channel number, input amp unit type, and waveform color are indicated in this portion. Pressing this button displays the Amp Details screen.
- 2) Basics - Input  
Input mode can be selected. Pressing this button permits mode switching, ON → GND → OFF → ON.
- 3) Basics - Position  
This button is used to set the zero position. Pressing this button changes the button appearance. The setup can be made with the jog dial.
- 4) Basics - Range  
This button is used to set the range. Pressing this button changes the button appearance. The setup can be made with the jog dial.
- 5) Basics – Lo V  
The LED lights if the high sensitivity range can be permitted.
- 6) Basics - Information indication  
This portion indicates settings that are unable to be set on this screen. When changing the settings, make the settings in the Amp Details screen.  
Fc: Filter setting  
Couple: Input coupling setting

### 7) Details - Position

The zero position (base line) is set with a button. The zero position means the waveform display position at 0V input (input short). The base line can be set in 5% steps in reference to 100% as the full scale. Also, you can set it with the jog dial by pressing the jog button, or set it from the numeric input window by pressing the window button. And the position change is available through the setup of Physical Unit Conversion or Printing/Display Range. For more information, see Chapter 4. Physical Unit Conversion – Changing Printing/Display Range.

### 8) Details – Input Coupling

The input coupling is set by pressing the AC coupling button or DC coupling button.

#### **TIPS**

When the AC coupling button is pressed, a capacitor is connected to the input terminal. The DC component can be eliminated, which enables the measurement of alternating voltage.

### 9) Details - Auto range

The range is automatically adjusted to the input signal.

### 10) Details - Range indication

The value of the current display range is displayed.

"#" is displayed when selecting the "Wide" range or changing "Printing / Display Range". After that, if you select the "Normal" range, the setting of "Printing / Display Range" is cleared and "#" disappears.

Also, when checking "Set EU." on the "User Conv." Tab and setting to use physical unit conversion, the full scale converted value will be displayed with \*.

For more information on physical unit conversion and printing / display range setting, see Chapter 4. Physical Unit Conversion - Changing Printing / Display Range.

### 11) Details - Wide/Normal

Wide: Entire measuring range is displayed.

Normal: Half of the measuring range is displayed (Default).

### 12) Details - Range

Range can be directly set.

#### **TIPS**

When the measurement range is changed, the waveform clip range is cleared to the default value corresponding to the new range.

Example: During expansion of the waveform in the waveform clip range between +40 and -40 at 100 V, if the range is set to 100 V again, the waveform clip range is set to between +50 to -50 as the default. (Enlarged display is cancelled.)



CAUTION

Pay attention to the permissible input voltage when setting the range.  
See Permissible input voltages in "Input Signals".

### 13) Details - Permission of high sensitivity settings

Settings of the high-sensitive range (5 V to 100 mV) can be prohibited/permitted.

When using the high-sensitivity range, check the check box.

When the high-sensitivity range is not used, prohibition of the high-sensitivity range without checking the box is recommended for safety.

### 14) Details - Filter

This button is used to set the low-pass filter.



### 1.3.3. Specifications of 2ch High-Speed DC Amp Unit (HSDC, Model AP11-103)

Number of channels	2 channels (chs)/unit	
Input mode	Unbalanced input (Each channel is insulated to each other and also from cabinet.)	
Input coupling modes	AC coupling and DC coupling	
Sensitivity and Accuracy	Input range	0.1, 0.2, 0.5, 1, 2 and 5 V-FS (Voltages exceeding $\pm 30\text{V}$ shall not be applied for the ranges 0.1 - 5 V-FS in AC coupling.) 10, 20, 50, 100, 200 and 500 V-FS For every range (i.e., $\pm 0.1$ - $\pm 500$ V-FS), fine adjustment capability and wide-scale provisions are provided.
	Accuracy	within $\pm 0.5\%$ -FS <b>* within <math>\pm 1\%</math>-FS for 500 V-FS</b>
Offset accuracy	within $\pm 0.5\%$ -FS <b>* at 23°C of environment temperature of mainframe operation</b>	
Input impedance	No less than 1 M $\Omega$	
Permissible input voltage	$\pm 500\text{V}$ (DC or AC peak value) <b>* <math>\pm 100\text{V}</math> (DC or AC peak value) for input ranges of 0.1 - 5 V-FS</b>	
Permissible common mode input voltage (CMV)	$\pm 42$ V (DC or AC peak value) for an amplifier unit only <b>* 300 VAC when an insulated BNC cable (signal cable 0311-5175) is used</b>	
Common mode rejection ratio (CMRR)	No less than 80 dB for frequencies DC - 60 Hz	
Frequency characteristics	For DC coupling: Within the range of +0.5 dB and -3 dB for frequency range of DC - 400 kHz For AC coupling: Within the range of +0.5 dB and -3 dB for frequency range of 0.3 Hz - 400 kHz	
Linearity	Within $\pm 0.2\%$ -FS	
Low pass filter	Two-pole Bessel type: 5Hz, 50Hz, 500Hz, 5kHz, 50kHz and OFF Attenuation characteristics: -12 dB/oct. approximately	
Temperature stability characteristics	Zero point: within $\pm 0.03\%$ -FS/ $^{\circ}\text{C}$ Range: within $\pm 0.01\%$ -FS/ $^{\circ}\text{C}$	
A/D conversion characteristics	Resolution	12 bits
	Conversion time	1 $\mu\text{s}$ max.
	Conversion method	serial comparison method
Input connector	Insulated BNC type	
Withstand voltage	1.5 kV AC for one minute between input terminal and ground, and between channels.	
S/N ratio	-46 dB or greater (when set at Wide Range)	
Mass	About 240 g	

1.3.4. External drawings of 2ch High-Speed DC Amp Unit (HSDC, Model AP11-103)

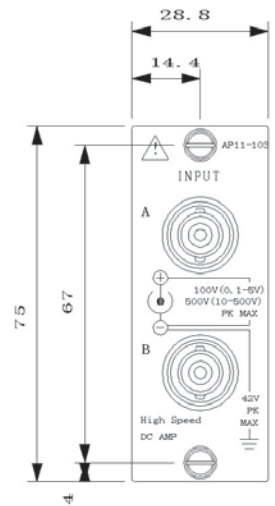
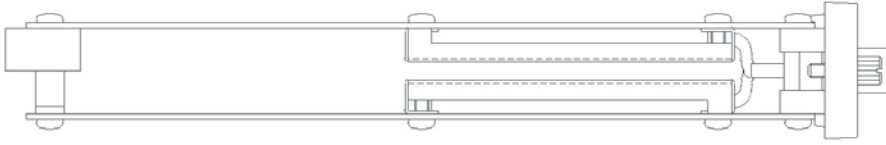

## 1.4.2ch AC Strain Amp Unit (ACST, Model AP11-104A)

The 2ch AC Strain Amp Unit is an A/D conversion unit that converts output voltages of transducers of the strain gauge type or strain gauges with bridge box connected to the input.

The unit provides high accuracy and resolution measurement with low noise due to the use of AC (alternate current) bridge source.

The units incorporate two (2) channels per unit and the two channels are insulated to each other within the unit.

### 1.4.1. Connection with input signals

**NOTE**

The AC source unit (optional item: RA23-143) must be installed in the RA recorder unit, when the 2ch AC strain amplifier unit is used.

■ **Connection instructions:**

The input section of the 2ch AC strain amplifier unit is illustrated in the figure below.

The input connectors are connected to strain gauge-type transducers or bridge boxes.

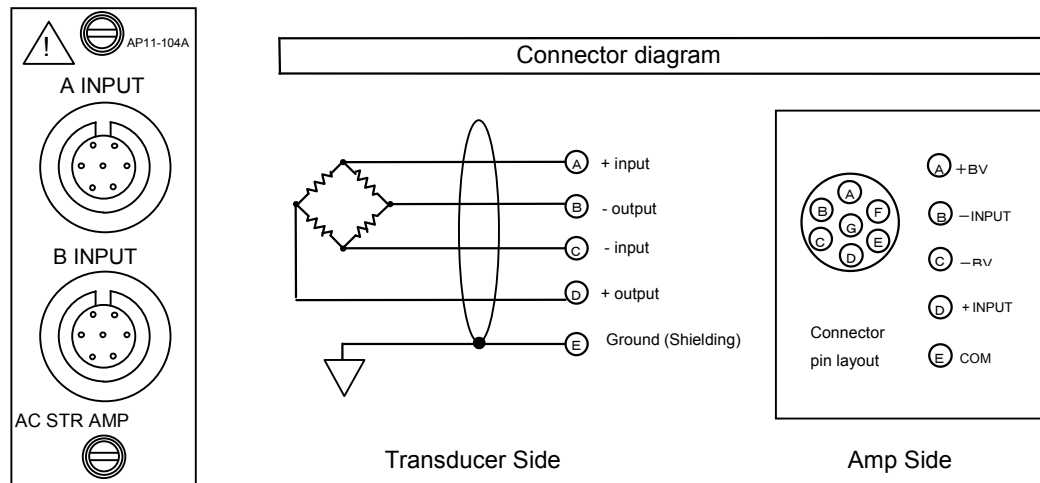

Correct and careful connection of the input circuit is vital to accurate and low-noise measurement.

The following describes the procedure of connecting input signals to the amplifier unit:

- 1) To paste strain gauges at locations to be measured.
- 2) To connect the strain gauges to the bridge box. Make your effort to shorten the length of connecting cables between the locations to be measured and the amplifier unit, since the shorter cables will provide the lower voltage drop due to line resistance.
- 3) To connect the bridge box and the transducers to the input unit.

■ **Notes on the use of bridge box and transducers**

Please observe the following points when you use a bridge box and transducers:

**NOTE**

To tightly fix transducers at place by referring to the transducer instruction manual, since unstable fixation of the transducers will lead to equipment malfunctioning and/or noise generation.

**NOTE**

To use transducers that do not have connections between the ground (shield) terminal and any of the other terminals (A, B, C and D) of this product.

**NOTE**

Not to place transducers and connecting cables in the environment with high electric or magnetic field.

## 1. How to Use Amp Unit (2ch AC Strain Amp Unit)

### NOTE

When the length of cables connecting this product to the bridge box or transducers is large, you will have measured values substantially lower than the actual value by the amount of voltage drop of bridge source due to line resistance. The error caused by the voltage drop can be corrected by using the following table listing bridge voltage drop factors.

Bridge resistance ( $\Omega$ )	Bridge Voltage Drop Rate (approximate in %)			
	Length of cable between this product and bridge box (Wire type: AWG20, at +20°C)			
	20 m	50 m	100 m	200 m
120	- 1.2	- 3.0	- 5.8	- 11.0
350	- 0.4	- 1.1	- 2.1	- 4.1
500	- 0.3	- 0.7	- 1.5	- 2.9
1000	- 0.1	- 0.4	- 0.7	- 1.5

### 1.4.2. How to set 2ch AC Strain Amp Unit (ACST, Model AP11-104/104A)

This section covers operations in the Amp Basic Screen that appears when the Amp button on the operation panel is pressed and the Amp Details Screen that appears when a channel button is pressed.

The diagram illustrates the relationship between the physical hardware and the software interface. On the left, the physical unit is shown with several controls: a channel selector (CH7 ACST), an input mode selector (ON, GND, OFF), a zero position dial (50.00%), a range dial (30k  $\mu\epsilon$ ), a filter selector (OFF), a calibration dial (OFF), and a balance selector (Auto Balance, R-Balance). On the right, the software interface shows the 'Detail' screen for CH7 ACST, with settings for input mode (ON), range (20  $\mu\epsilon$ ), filter (OFF), calibration (OFF), and balance (Auto Balance). Arrows indicate the mapping between the physical controls and the software settings.

- 1) Basics - Channel  
The channel number, input amp unit type, and waveform color are indicated in this portion. Pressing this button displays the Amp Details Screen.
- 2) Basics - Input  
Input mode can be selected. Pressing this button permits switching among ON, GND and OFF.
- 3) Basics - Position  
This button is used to set the zero position. Pressing this button changes the button appearance. The setup can be made with the job dial.

- 4) Basics - Range  
This button is used to set the range. Pressing this button changes the button appearance, and then the setup can be made with the jog dial. The displayed contents are those in Strain Measurement.
  
- 5) Basics - Information indication  
This portion indicates settings that are unable to be set on the basic screen. When changing the settings, make the settings in the Amp Details Screen.  
Fc: Filter setting  
CAL: Calibration setting  
Gauge: Gauge factor setting
  
- 6) Details - Position  
The zero position (base line) is set with a button. The zero position means the waveform display position at 0V input (input short). The base line can be set in 5% steps in reference to 100% as the full scale. Also, you can set it with the jog dial by pressing the jog button, or set it from the numeric input window by pressing the window button. And the position change is available through the setup of Physical Unit Conversion or Printing/Display Range. For more information, see Chapter 4. Physical Unit Conversion – Changing Printing/Display Range.
  
- 7) Details - Range indication  
The value of the current display range is displayed.  
"#" is displayed when selecting the "Wide" range or changing "Printing / Display Range". After that, if you select the "Normal" range, the setting of "Printing / Display Range" is cleared and "#" disappears.  
Also, when checking "Set EU." on the "User Conv." Tab and setting to use physical unit conversion, the full scale converted value will be displayed with \*.  
For more information on physical unit conversion and printing / display range setting, see Chapter 4. Physical Unit Conversion - Changing Printing / Display Range.
  
- 8) Details - Wide/Normal  
Wide: Entire measuring range is displayed.  
Normal: Half of the measuring range is displayed (Default).
  
- 9) Details - Range  
Range can be directly set.

**TIPS**

When the measurement range is changed, the waveform clip range is cleared to the default value corresponding to the new range.

- 10) Details - Filter  
Value for the low-pass filter can be set.
  
- 11) Details - Calibration  
Calibration is made using the positive or negative symbols after setting a calibration value. Positive is tension and negative is compression. The calibration should be set to OFF before executing measurement.
  
- 12) Details - Balance  
Pressing the Auto Balance button automatically performs C and R balances, thereby canceling the initial imbalance (offset). If the adjustment cannot be made correctly, the R-Balance can be adjusted by turning the jog dial after pressing the R-Balance button.

### 1.4.3. Gauge Factor Setup

When the input mode is strain, the gauge factor can be set based on the strain gauge being used. Setting the gauge factor outputs the measurement value with corrections. The corrections are effective on digital value indication and trigger level. Press the Gauge Factor button in the Expansion tab in the Amp Details screen to set the gauge factor with the jog dial. Alternatively, press the Window button to set the gauge factor through the value entry window.

Setup range	1.50 to 2.50
Resolution	0.01
Default	2.00

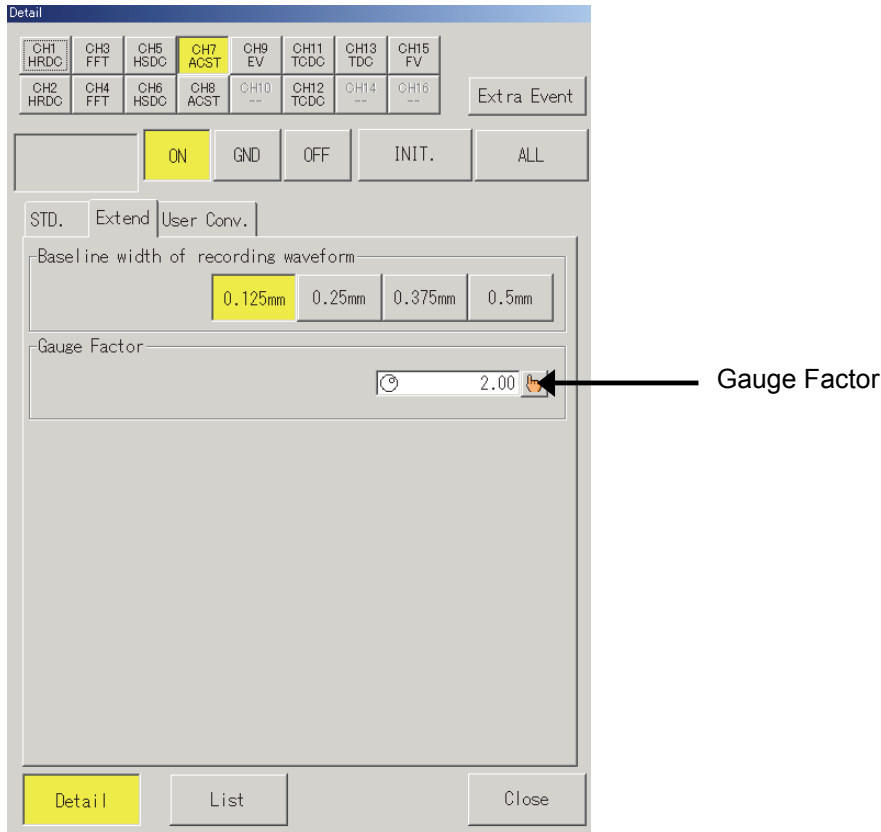

### 1.4.4. How to read Measured Values

This section describes how to read the measured values of a waveform recorded on a data acquisition device or recorder.

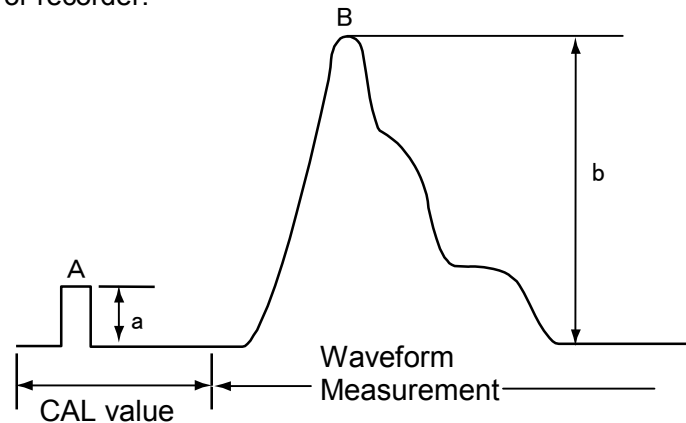

$$\text{Measured value at point B} = \left\{ \frac{b \text{ (Amplitude at point B)}}{a \text{ (Amplitude of calibration value)}} \right\} \times \text{Set CAL value}$$

#### (1) Measurement with strain gauges

Set CAL value: 500  $\mu\text{m/m}$

Deflection of CAL waveform: 10 mm

Deflection at point B: 22 mm

$$\begin{aligned} \text{Amount of strain at point B} &= \{22/10\} \times 500 \mu\text{m/m} \\ &= 1100 \times \mu\text{m/m} \end{aligned}$$

Where the measurement is based on the quarter-bridge configuration with a gauge factor of 2.00.

#### (2) Measurement with various types of transducers

For this calibration voltage value, the calibration value set with ⑪ can be applied..

Example:

When a load cell with a rated capacity of 10 kN and a rated output of 1 mV/V is used, to convert the rated output of 1 mV/V into an amount of strain, the rated output is given by:

$$1 \text{ mV/V} \times 2\text{V} = 2 \text{ mV}$$

Where the load cell is used with the bridge voltage (E) = 2V.

If the measurement is based on the quarter-bridge configuration with a gate factor (K) of 2.00, the relationship between the amount of strain ( $\epsilon$ ) to be applied to the bridge and the output voltage (e) is given by:

$$e = 1/4 \times K \times E \times \epsilon = 1/4 \times 2 \times 2 \times \epsilon = \epsilon$$

That is, 1  $\mu\text{m/m}$  strain corresponds to 1  $\mu\text{V}$  and 1000  $\mu\text{m/m}$  strain corresponds to 1 mV, rated output of 2 mV corresponds to 2000  $\mu\text{m/m}$ . As a result, the relationship between calibration values and the physical amount is as follows irrespective of the bridge supply voltage:

Strain calibration value	Physical value calibration value
2000 $\mu\text{m/m}$ strain	10kN $\times$ 1 =10kN
1000 $\mu\text{m/m}$ strain	10kN $\times$ 1/2 =5kN
500 $\mu\text{m/m}$ strain	10kN $\times$ 1/4 =2.5kN
200 $\mu\text{m/m}$ strain	10kN $\times$ 1/10 =1kN

The formula is as follows:

$$\text{Calibration value of physical amount} = \frac{\text{CAL value of the amplifier } (\mu\text{m/m strain})}{\text{Rated output value } (\mu\text{m/m strain})} \times \text{Rated capacity}$$

The physical amount can be calculated as follows:

Calibration value of physical amount: 2.5kN (500  $\mu\text{m/m}$ )

Deflection of CAL waveform: 10 mm

Deflection at point B: 22 mm

## 1. How to Use Amp Unit (2ch AC Strain Amp Unit)

The physical amount can be calculated as follows:

$$\text{Load at point B} = \frac{22}{10} \times 2.5\text{kN} = 5.5\text{kN}$$

### (3) Correction of Calibration (CAL) Values

In this amplifier unit, its gauge factor is set to 2.00. If strain gauges with a gauge factor other than 2.00 are to be used, the following formula must be used.

$$\text{True CAL value} = \frac{2.00}{Kc \text{ (Gauge factor of strain gauge)}} \times \text{CAL value of unit}$$

### (4) Where the distance from the bridge box to the amplifier unit is long

If the cable from the bridge box or a transducer to the amplifier unit is long, the bridge supply will drop due to the conductor resistance of the cable. This causes errors between the bridge output voltage and the CAL value. For obtaining the voltage drop rate, refer to Table "Bridge Voltage Drop Rate" or measure the voltage between terminals A and C on the bridge box, using a voltmeter.

Example:

If the cable length is 100 m and the strain gauge resistance is 120  $\Omega$  under an ambient temperature of 20°C, the bridge supply voltage will be reduced by 5.8% between terminals A and C, which can be obtained from Table "Bridge Voltage Drop Rate".

The true calibration value can thus be given by:

$$\text{True calibration value} = \frac{1}{1-0.058} \times \text{Calibration value}$$

Bridge resistance ( $\Omega$ )	Length of cable between this product and bridge box (wire type: AWG20, at +20°C)			
	20 m	50 m	100 m	200 m
120	- 1.2	- 3.0	- 5.8	- 11.0
350	- 0.4	- 1.1	- 2.1	- 4.1
500	- 0.3	- 0.7	- 1.5	- 2.9
1000	- 0.1	- 0.4	- 0.7	- 1.5

**Bridge Voltage Drop Rate (approximate in %)**

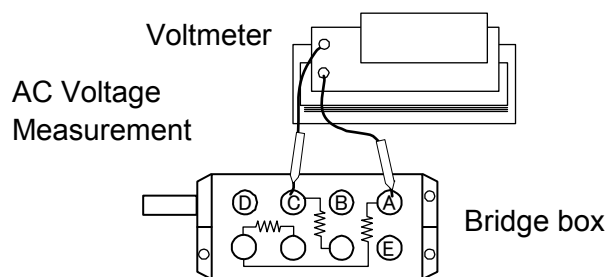

**Voltage measurement on bridge box**



### 1.4.5. Synchronization between AC Bridge Power Supply Units (RA23-143)

When you use multiple recorder units, you should synchronize the operation of their AC Bridge Power Supply Units.

Define one (1) of the AC Bridge Power Supply Units as a master unit for the whole system. And switch the OSC switch of the master AC Bridge Power Supply Unit to the "INT" position. Switch the OSC switches of all the other AC Bridge Power Supply Units (i.e., slave units) to the "EXT" position.

#### ■ Synchronization of two RA2300MK II recorder units

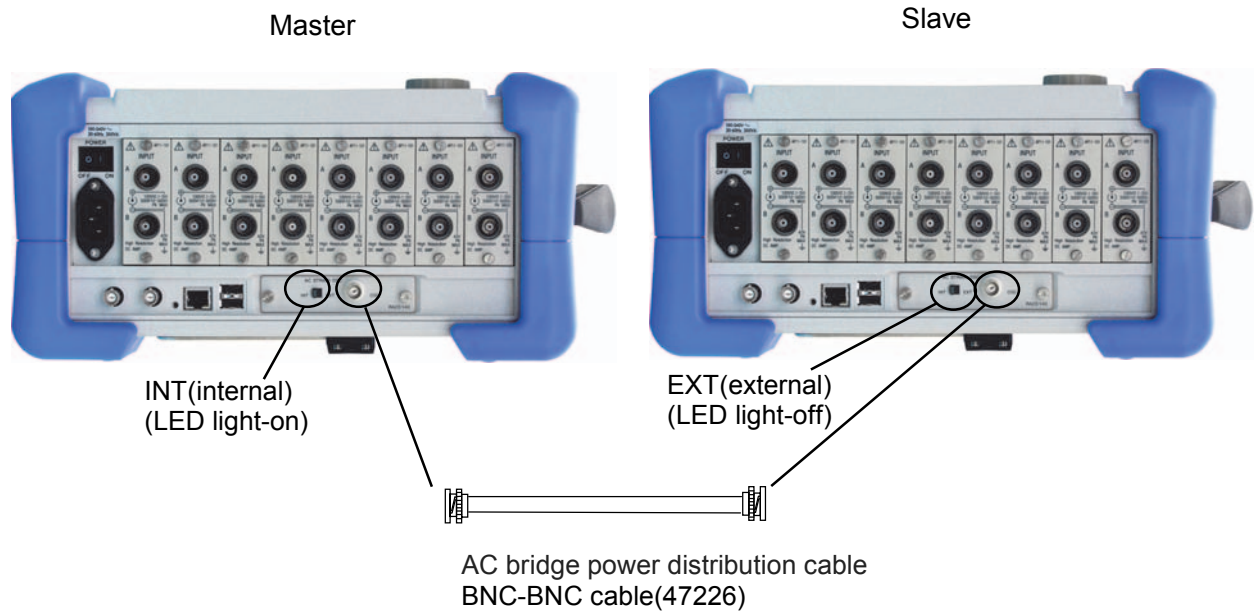

#### ■ Synchronization of three or more recorder units

BNC adapters (0243-2118) will be needed when you synchronize three or more power supply units.

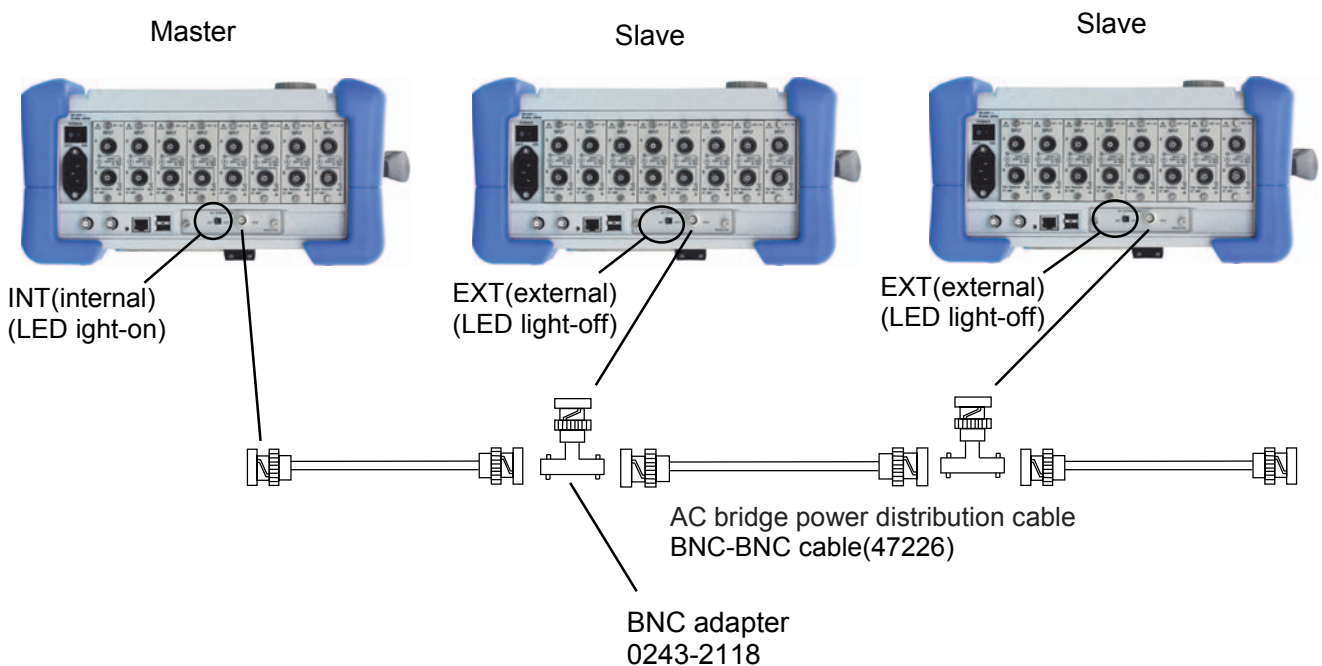

### ■ Synchronization of two RA2800A recorder units

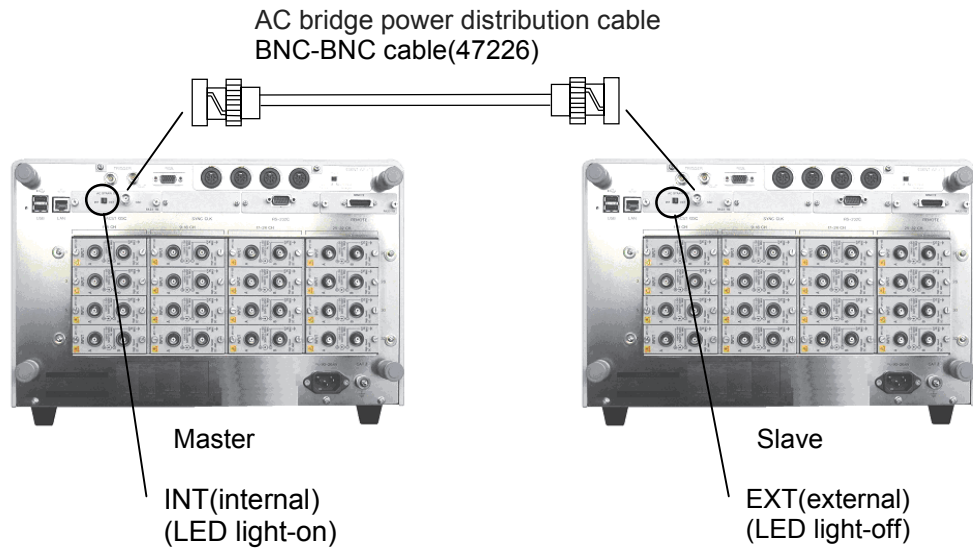

### ■ Synchronization of three or more recorder units

BNC adapters (0243-2118) will be needed when you synchronize three or more power supply units

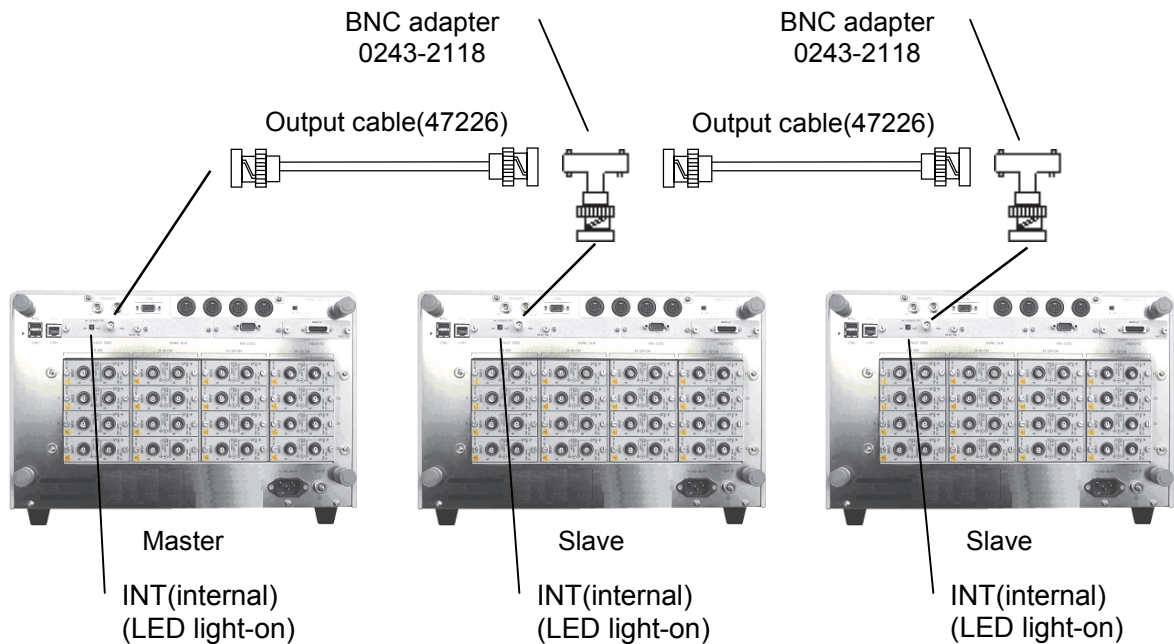

## 1.4.6. Specifications of 2ch AC Strain Amp Unit (ACST, Model AP11-104A)

Number of channels	2 channels (chs)/unit	
Input mode	Balanced input (Each channel is insulated to each other and also from cabinet in the unit.)	
Applied strain gauge resistance	120Ω - 1 kΩ	
Gauge factor	2.00 (when factory shipped) 1.50 to 2.50 changeable	
Bridge voltage source	Sine wave, 2 Vrms, 5 kHz <i>*The bridge voltage source is a separate unit called AC Bridge Power Supply Unit (RA23-143).</i>	
Auto Balance	Time required	within 1 sec./channel
	Accuracy in residual voltage	within ±0.5%-FS
Adjustable range of balancing	Resistance component: within ±2% (10000 μm/m of strain) Capacitance component: within 2000 pF	
Voltage sensitivity	At least the amount of FS (full scale) for the strain of 500 μm/m	
Measurement range	1k, 2k, 5k, 10k, 20k με (μm/m of strain)	
Permissible common mode input voltage (CMV)	300 VAC	
Calibration (internal calibrator)	±500, 1k, 2k, 5k, 10k, 20k με (μm/m of strain) Accuracy: within ±0.5 %-FS	
Frequency characteristics	Within the range of +1 dB and -3 dB for frequency range of DC - 2 kHz	
Linearity	Within ±0.2%-FS	
Low pass filter	Two-pole Butterworth type: 10Hz, 30Hz, 100Hz, 300Hz and OFF Attenuation characteristics: -12 dB/oct.	
Temperature stability characteristics	Zero point: within ±0.05%-FS/°C Range: within ±0.05%-FS/°C	
A/D conversion characteristics	Resolution	16 bits
	Conversion time	10 μs max.
	Conversion method	Serial comparison method
Input connector	NDIS strain input connector	
Withstand voltage	1 kV AC for one minute between input terminal and ground, and between channels.	
S/N ratio	-46 dB or greater (when set at Wide Range)	
Mass	About 285 g	

Note: "μ ε" and "x 10<sup>-6</sup> of strain" means "μm/m of strain".

1.4.7. External drawings of 2ch AC Strain Amp Unit (ACST, Model AP11-104/104A)

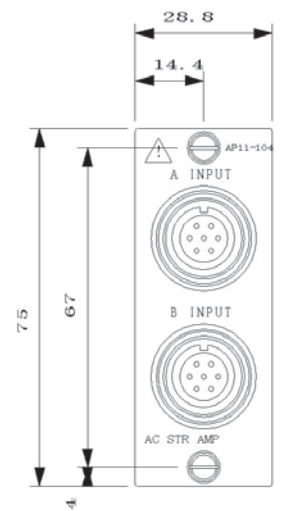
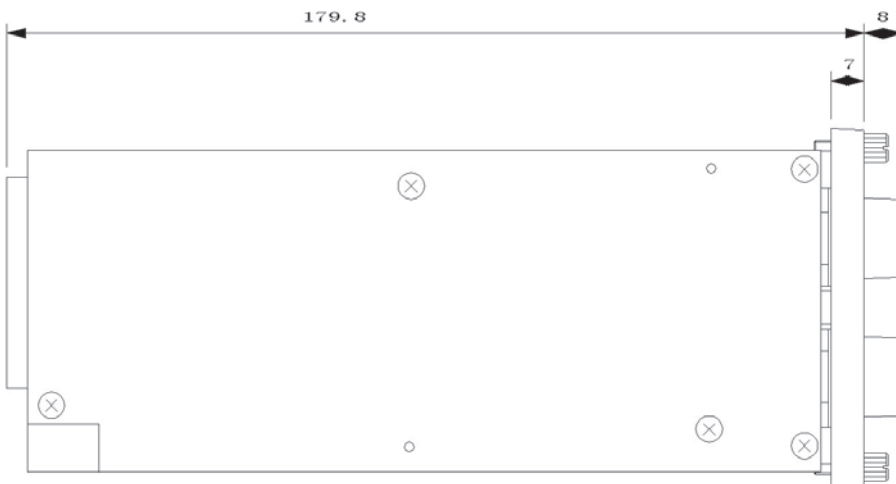
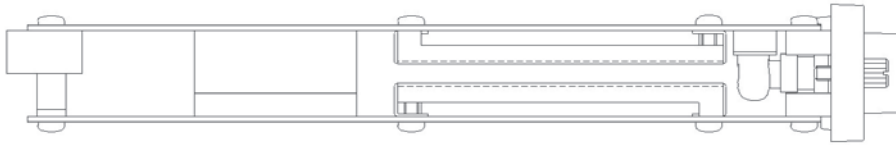

## 1.5. Event Amp Unit (EV, Model AP11-105)

The Event Amp Unit provides status judgment information, such as that of voltage levels (H-level and L-level) and of electric contacts (open and short). One unit can have connections of up to eight (8) inputs and all inputs have a common ground.

### 1.5.1. Connection with input signals

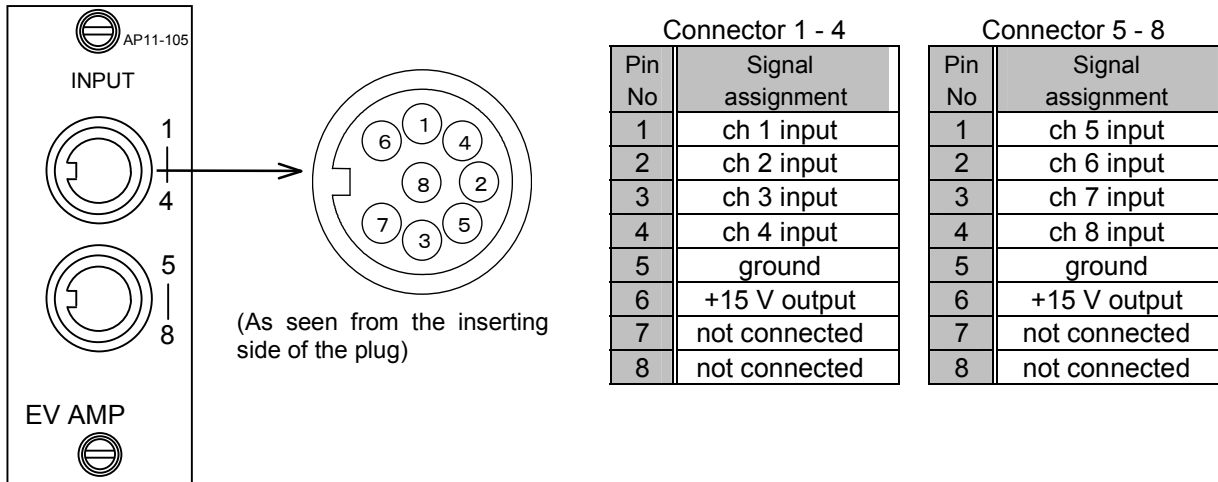

### Input signals

	Range of input voltage	0 - +24 V
Voltage input	Detection levels	H-level: more than approximately 2.5 V L-level: less than approximately 0.5 V
	Input impedance	No less than 1 MΩ
	Contact input	Open: no less than 2 kΩ Short: no more than 250 Ω
	Load current	2 mA (MAX)

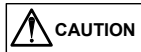

Be careful that the input impedance will decrease up to 50 kΩ approximately if the input voltage exceeds the specified range of input voltage, when you apply voltages at the input.

### Logic IC probes

The logic IC probes comprise a logic IC cord, an IC clip cord and a test clip cord. Connection with the logic IC cord should be made so that both connecting and connected lines have the same color.

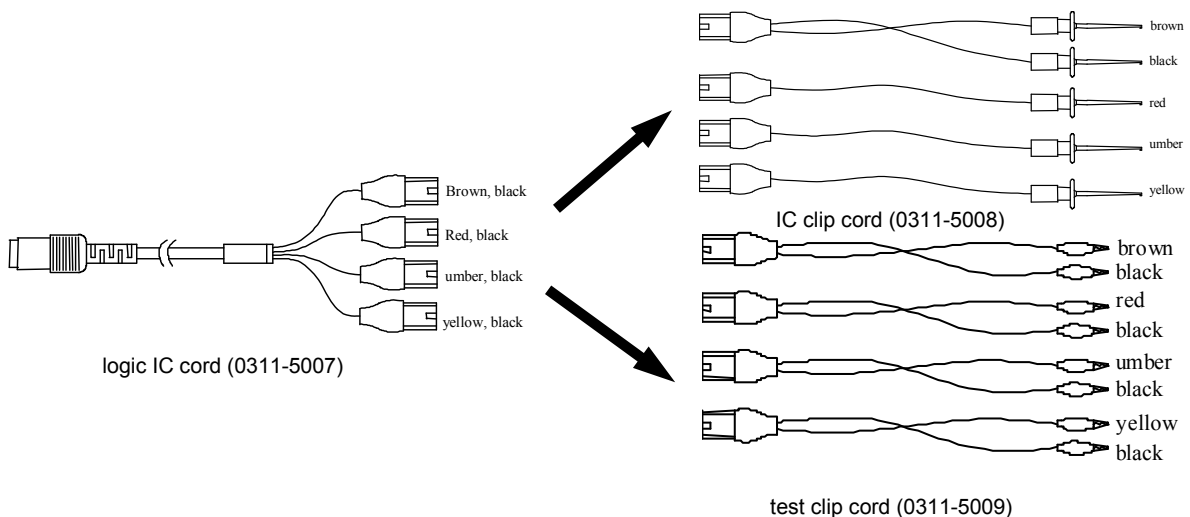

## 1. How to Use Amp Unit( Event Amp Unit)

(continued from the previous page)

Channel numbers within event amplifier unit		Logic IC cord	IC clip cord	Test clip cord
1	5	brown, black	brown, black	brown, black
2	6	red, black	red	red, black
3	7	umber, black	umber	umber, black
4	8	yellow, black	yellow	yellow, black

### 1.5.2. How to set Event Amp Unit (EV, Model AP11-105)

This section covers operations in the Amp Basic screen that appears when the Amp button on the operation panel is pressed and the Amp Details screen that appears when a channel button is pressed.

The following shows the contents of the EV Amp.

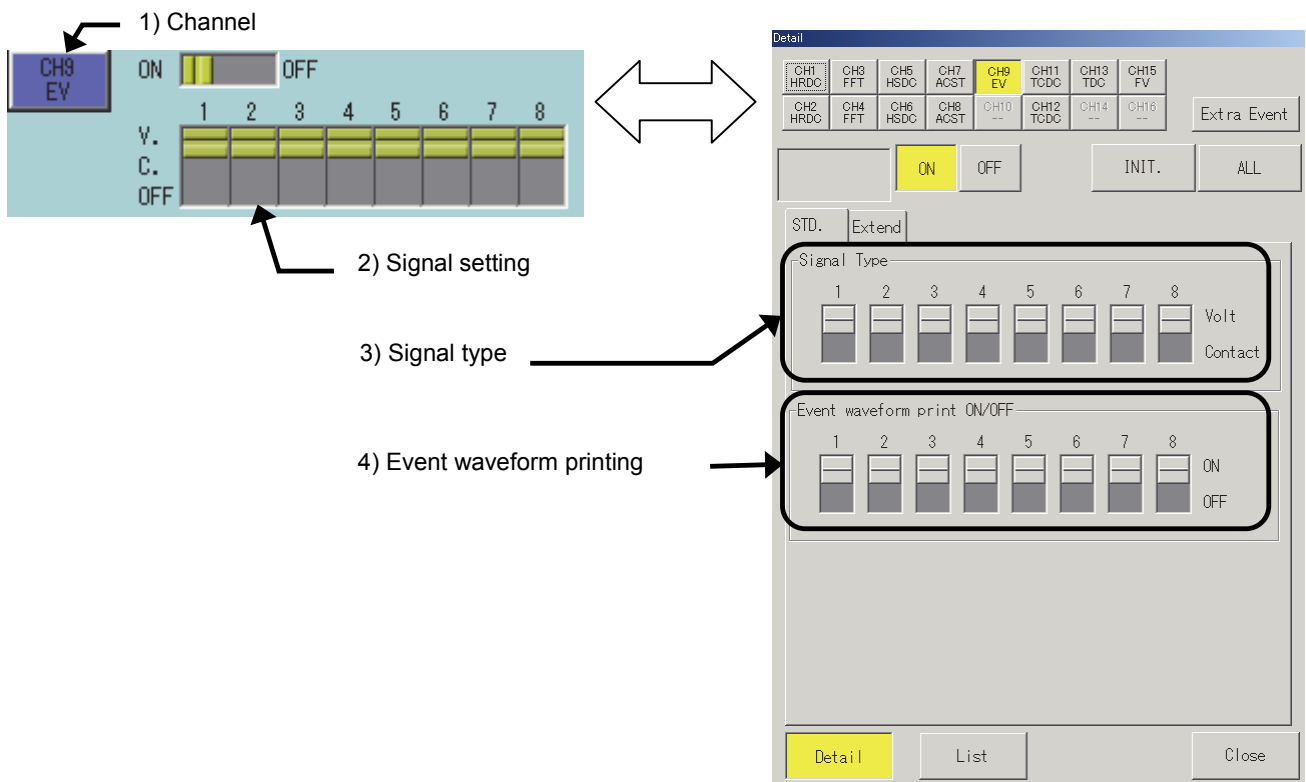

- 1) Basics - Channel  
The channel number, input amp unit type, and waveform color are indicated in this portion. Pressing this button displays the Amp Details screen.
- 2) Basics - Signal  
This is used to set the signal type and event waveform printing. Three levels are set: V (Voltage), C (Contact) and off (waveform printing OFF). Touching this portion switches to V, C and OFF in this order by each signal for eight signals..
- 3) Details - Signal type  
This is used to set the 8 signals each. Touching this portion switches the signals to Volt and Contact in order.
- 4) Details - Event waveform printing  
This is used to switch the event waveform printing to ON/OFF by each signal for eight signals. Touching this portion switches the signals to ON and OFF.

### 1.5.3. Adjustment of event waveform

This section covers adjustment of the event waveform in the Expansion tab in the Amp Details screen. In the adjustment of the event waveform, settings for monitor display, waveform printing point, pitch between signals, signal amplitude and line thickness can be changed. The waveform can be adjusted to have good visibility to the measuring condition.

Press the jog button of “Position”, “Sig. Pitch”, “Amplitude”, and “Line Thickness” on the Extension tab of the Amplifier Details screen and you can set each with the jog dial. Or set each from the numeric input window by pressing the window button.

Touching the Auto adjust button automatically makes adjustment so that the event waveform printing is exactly positioned on the grid.

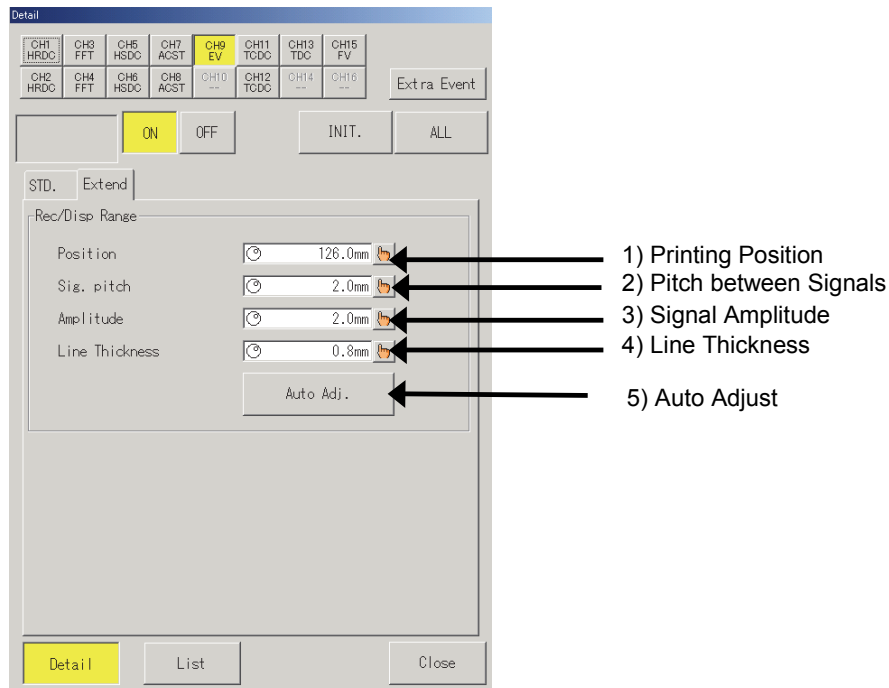

- 1) Printing position  
This value specifies the waveform position of signal 8. The signals 1 to 8 are positioned above signal 8 in the interval specified in Pitch between signals.
- 2) Pitch between signals  
This value specifies the interval between the waveform positions of all eight signals.
- 3) Signal amplitude  
This value specifies the height of the waveform amplitude (length between H and L points).
- 4) Line Thickness  
This value specifies the waveform width at the H point.
- 5) The event waveform printing point is automatically adjusted so as to be exactly positioned on the grid.

**NOTE**

Extremely high setting values for Printing Portion and Pitch between Signals exceed the effective printing width, which will disable event waveform printing.

1.5.4. Specifications of Event Amp Unit (EV, Model AP11-105)

Number of channels	8 channels (chs)/unit		
Input mode	Logic input (insulation: between each ch and chassis), Common of each channel is connected in the unit.		
Input signals	You can set Volt/Contact separately for each channel input.		
	Voltage input (Volt)	Range of input voltage	0 - +24V
		Detection level	H-level (H): more than approx. 2.5 V L-level (L): less than approx. 0.5 V
		Input impedance	No less than 1 MΩ
Contact input (Contact)	Detection level	Short(H):no more than 250Ω Open(L):no less than 2kΩ	
	Load current	2 mA(max.)	
Response time	1μS <i>*applies when the input level "H" is +5 V or more.</i>		
Waveform recording	The thick line and the thin line are allocated for recording the logic levels of "H" and "L", respectively. (The "short" status of contact inputs is recorded as the "H" level.) [Judgment of H/L levels]		
	H-level		
	L-level		
	The display position, inter-signal pitch, signal amplitude and line thickness can be changed for up to two (2) units when the full-scale is set to 1/1.		
	Display position	can be set in the range 0.0 – 198.0 mm	
	Signals pitch	can be set in the range 2.0 – 25.0 mm	
Signal amplitude	can be set in the range 2.0 – 25.0 mm		
Line thickness	can be set in the range 0.5 – 2.0 mm		
Can be set with 0.1 mm pitch			
Data recording	Recordings of "1" and "0" are made for logic levels of "H" and "L", respectively.		
X - Y recording	N/A (not applicable)		
Insulation resistance	No less than 100 MΩ between input terminal and ground		
Withstand voltage	500 VAC for one minute between input terminal and ground		
Mass	About 100 g		

■ Round DIN connector 8P XT2B-0800 (conforms to DIN45326)

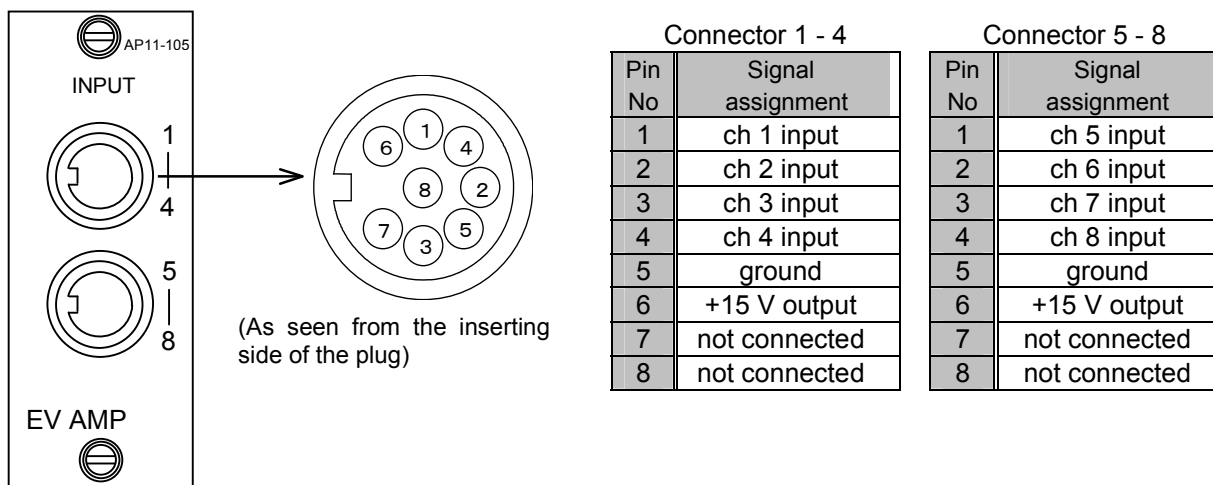



<Logic IC probes-----accessory to Event Amp Unit>

Use	Logic IC probes are used for connection of the event amplifier unit with electronic circuits or sequence circuits for measurement of digital signals and/or relay contact signals.		
	Wire color	Corresponding input channels	
	Brown	ch 1	ch 5
	Red	ch 2	ch 6
	Umber	ch 3	ch 7
	Yellow	ch 4	ch 8
Black	ground	ground	
Composition	Logic IC cord (0311-5007)	One (1), 1.5 m long	
	IC clip cord (0311-5008)	Four (4)/sack, 15 cm long	
	Test clip cord (0311-5009)	Four (4)/sack, 15 cm long	
	The above comprises one (1) set of probe; two (2) are provided with each unit.		

1.5.5. External drawings of Event Amp Unit (EV, Model AP11-105)

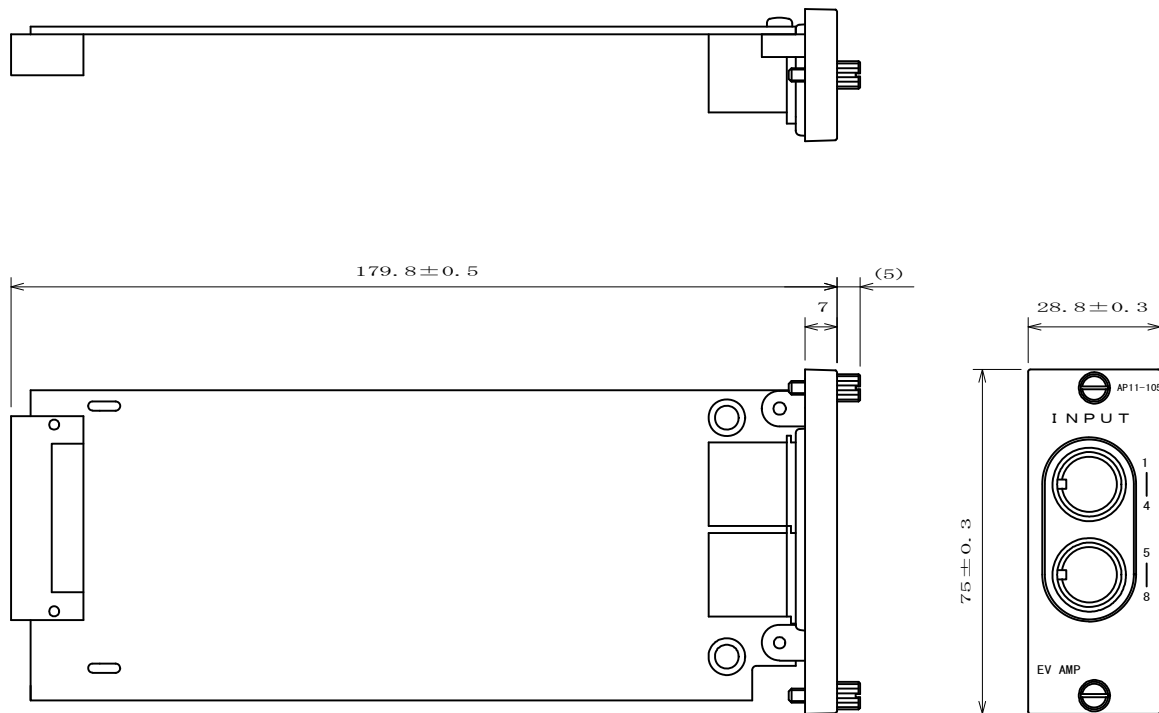

## 1.6. 2ch TC-DC Amp Unit (TCDC, Model AP11-106/106A)

The 2ch TC·DC Amp Unit is used to make temperature measurement by directly connecting thermocouples (R, T, J, K and W) to their input terminals. The units can also be used as DC amplifiers. The units incorporate two (2) channels per unit and the two channels are insulated to each other within the unit.

### 1.6.1. Connection with input signals

#### ■ Connection instructions:

It is very important to correctly connect input circuits to make accurate measurement with low noise level.

Basically, connect input circuits as shown in the following:

Positive + (plus) side screw of input terminal block:

High impedance side of thermocouple or signal source (i.e., H-side: hot side)

Negative –(minus) side screw of input terminal block:

Low impedance side of thermocouple or signal source (i.e., L-side: low side)



#### NOTE

- # Do not use unnecessarily long cables for input connection.
- # Use shielded cables for input connection to avoid electrostatic noise.
- # Twist the positive (+) and negative (-) lines of the input cable to avoid magnetic noise.
- # Please keep the signal source impedance as low as possible, i.e., less than 100 Ω.
- The lower the signal source impedance is, the higher the quality of measurement record is.

#### ■ Notes and tips on the use of TC·DC Amp Unit:

TC·DC (temperature/voltage) Amp Unit can also be used as DC Amp.

The following describes some notes and tips on the use of TC·DC Amp units as temperature amplifiers and as DC amplifiers:

##### ● Use of TC·DC Amp Unit as temperature amplifiers

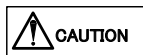

- # Directly connect the original raw wire or the compensation conductor of a thermocouple to the input terminal of the unit. Instead, you may use a crimping terminal (4 mm in diameter) with low heat capacity at the unit input terminal.
- # Connect a thermocouple to the input terminal particularly paying attention to the correctness of its polarity. If wrong connection in polarity is made for a thermocouple at the unit input terminal, the recorded temperature will be lower than the actual temperature.
- # When a thermocouple is directly connected to the unit input terminal, set an internal temperature compensation with a reference contact.
- # When a temperature compensation with a reference contact is set externally, you will also need an external temperature compensation for the reference contact such as a zero-control scheme.

- # Start your measurement at least 30 minutes after switching the power on, providing sufficient time period of equipment warm-up, so that stable measurement can be made.
- # Make temperature measurement at least about 10 minutes after thermocouples have been connected.
- # Accurate measurement cannot be made due to temperature gradient at the terminal section if the input terminal is directly hit by a hot wind or a cold wind. To cope with such a situation, put an enclosure around the input terminal.
- # When the unit is used as a temperature amplifier, the unit is not suitable to record signals in general (i.e., voltage measurement), since a built-in linearizer is connected to the circuit. In this case, set at "Measure with V".

● **Use of TC-DC Amp Unit as DC amplifiers**



- # Permissible input voltage:  
If you apply, by error, any voltages that are more than the permissible input voltage  $\pm 50$  V (in DC or in AC peak value), equipment failures would be induced due to breakdown of internal parts or other reasons. Do not apply input voltages exceeding the permissible input voltage.
- # Input impedance:  
The input impedance in the voltage input mode is approximately ten (10) M $\Omega$  at the ranges 100 mV - 2V-FS, and is approximately one (1) M $\Omega$  at the ranges 5 – 50 V-FS. However, note that the input impedance will be lowered to approximately 5 or 6 k $\Omega$  at minimum, when the input voltage exceeds  $\pm 6$  V (in DC or in AC peak value).

● **Common notes and tips:**



- # Use the unit by confirming the permissible common mode input voltages (CMV) to be no more than  $\pm 300$  V (in DC or in AC peak value).
- # Use such cables that have insulation sheath with no less than 2kV of withstand voltages.
- # Do not apply voltages exceeding the permissible common mode input voltage, since application of such voltages would lead to malfunctions or failures of equipment. Also, note that recorded waveforms may involve noise components due to degradation of common mode rejection ratio (CMRR), when noise-like impulsive common mode voltages are applied.
- # The sample speed must be set at 10 $\mu$ s steps, otherwise the signal waveform cannot be obtained correctly. Example : 5  $\mu$ s or 11  $\mu$ s, etc. makes the waveform distort.

**1.6.2. Kinds of thermocouple and the characteristics**

	Advantages	Disadvantages
K	Good linearity of electromotive force. Suitable to oxidized atmosphere.	Weak for reducing atmosphere. High electric resistance.
J	Cheaper than K thermocouple. High sensitivity. Nonmagnetic.	Weak for reducing atmosphere. High electric resistance.
T	Cheap and easy to get. Good low temperature characteristics. Suitable to reducing atmosphere.	Maximum operating temperature is low. Heat-conductive error is large.
R	High accuracy. Unevenness and deterioration are little. Good chemical resistance and oxidation resistance. Useable as standard.	No good linearity of electromotive force. Weak for reducing atmosphere. Impossible to measure lower temperature than 0 °C.
W	Suitable to inert gas and hydrogen-gas. Good characteristics in high temperature.	Not specified in JIS.

### 1.6.3. How to set 2ch TC·DC Amp Unit (TCDC, Model AP11-106/106A)

This section covers operation in the Amp Basic screen that appears when the Amp button on the operation panel is pressed and the Amp Detailed screen that appears when a channel button is pressed.

The displayed contents are the same as those in Celsius temperature measurement mode as shown below.

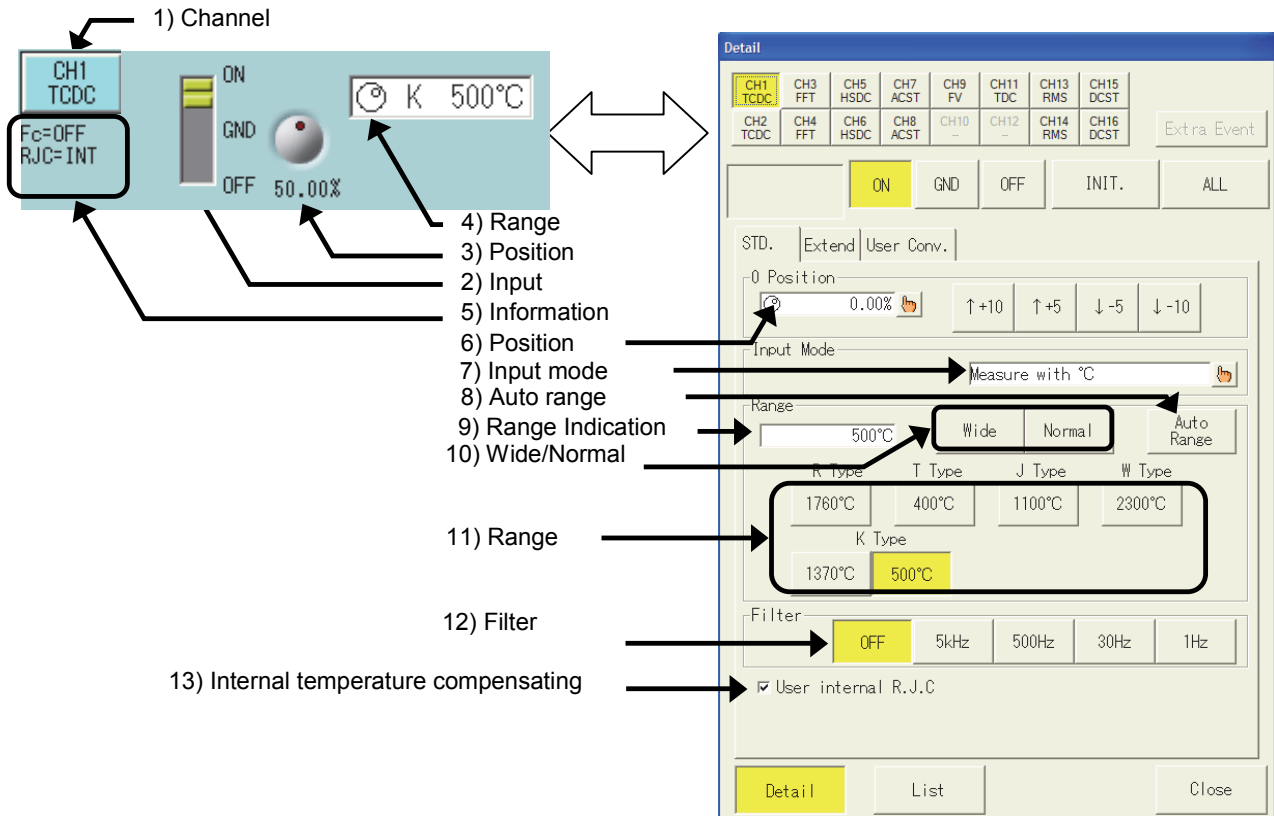

- 1) Basics - Channel  
The channel number, input amp unit type, and waveform color are indicated in this portion. Pressing this button displays the Amp Detailed screen.
- 2) Basics - Input  
Input mode can be selected. Pressing this button permits switching among ON, GND, and OFF.
- 3) Basic - Position  
This button is used to set the zero position. Pressing this button changes the button appearance. The setup can be made with the jog dial.
- 4) Basic - Range  
This button is used to set the range. Pressing the button changes the button appearance, and the setup can be made with the jog dial. The displayed contents are those in the temperature measurement mode. That is, the contents are different from those for the voltage measurement mode.
- 5) Basic – Information indication  
This portion indicates the settings that are unable to be set on this screen. When changing the settings, make the settings in the Amp Detailed screen.  
Fc: Filter setting  
RJC: Reference Junction select setting

## 6) Details – Position

The zero position (base line) is set with a button. The zero position means the waveform display position at 0V input (input short). The base line can be set in 5% steps in reference to 100% as the full scale. Also, you can set it with the jog dial by pressing the jog button, or set it from the numeric input window by pressing the window button. And the position change is available through the setup of Physical Unit Conversion or Printing/Display Range. For more information, see Chapter 4. Physical Unit Conversion - Changing Printing/Display Range.

## 7) Details – Input mode

This button is used to set the measurement mode of input signal. The change of range contents can be made to set input mode. When the voltage measurement is set, the temperature compensation setting will be invalid.

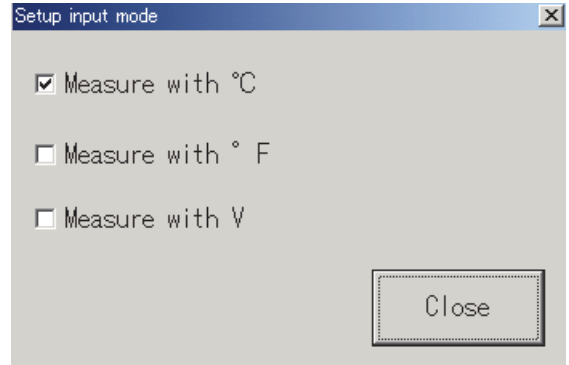

## 8) Details – Auto range

This button is automatically set the range adjustment corresponding to input signal.

## 9) Details – Range indication

The value of the current display range is displayed.

"#" is displayed when selecting the "Wide" range or changing "Printing / Display Range". After that, if you select the "Normal" range, the setting of "Printing / Display Range" is cleared and "#" disappears.

Also, when checking "Set EU." on the "User Conv." Tab and setting to use physical unit conversion, the full scale converted value will be displayed with \*.

For more information on physical unit conversion and printing / display range setting, see Chapter 4. Physical Unit Conversion - Changing Printing / Display Range.

## 10) Details – Wide/Normal

Wide: Entire measuring range is displayed.

Normal: Half of measuring range is displayed (Default).

## 11) Details - Range

The range can be directly set.

The change of range contents can be made to set input mode.

**TIPS**

When the measurement range is changed, the waveform clip range is cleared to the default value corresponding to the new range.

## 12) Details - Filter

Value for the low-pass filter can be set.

## 13) Details – Internal temperature compensation

The reference contact temperature compensation is made internally or externally. When the thermocouple is directly connected, tick this box (default). If using a zero-temperature compensating device, do not tick this box. This setting is only valid when the input mode is in temperature measurement.

1.6.4. Specifications of 2ch TC·DC Amp Unit (TCDC, Model AP11-106/106A)

Number of channels	2 channels (chs)/unit	
Input mode	Unbalanced input (Each channel in the unit is insulated to each other and also from cabinet.)	
Input coupling modes	DC coupling	
Applicable thermocouples	R, T, J, K and W	
Measurement range	Use of units as thermocouple amplifiers: Range of temperature measurement	
	Range	Display in Celsius      Display in Fahrenheit
	R Type	1760°C (0 - 1760°C)      3200°F (32 - 3200°F)
	T Type	400°C (-200 - 400°C)      752°F (-328 - 752°F)
	J Type	1100°C (-200 - 1100°C)      2012°F (-328 - 2012°F)
	K Type	500°C (-200 - 500°C)      932°F (-328 - 932°F)
	K Type	1370°C (-200 - 1370°C)      2498°F (-328 - 2498°F)
	W Type	2300°C (0 - 2300°C)      4172°F (32 - 4172°F)
	Equipped with fine adjustment capabilities in individual ranges	
	Use of units as DC amplifiers 100mV-FS, 200mV-FS, 500mV-FS, 1V-FS, 2V-FS, 5V-FS, 10V-FS, 20V-FS, 50V-FS Equipped with fine adjustment capabilities in individual ranges	
Accuracy	For the use of units as thermocouple amplifiers: within $\pm 0.5\%$ -FS For the use of units as DC amplifiers: within $\pm 0.3\%$ -FS of range accuracy and within $\pm 0.1\%$ -FS of linearity	
Reference Junction	Switch able between internal and external compensation	
Compensation accuracy for Reference Junction	Within $\pm 2^\circ\text{C}$ of accuracy (at input terminal section temperature equilibrium)	
Offset accuracy	For the use of units as DC amplifiers: within $\pm 0.3\%$ -FS At 23°C of environment temperature of mainframe operation	
Input impedance	No less than 10 M $\Omega$ Approximately 1 M $\Omega$ for the ranges of 5, 10, 20 and 50V-FS for use as DC amplifiers	
Permissible input voltage	$\pm 50$ V (in DC or in AC peak value)	
Permissible common mode input voltage (CMV)	$\pm 42$ V (in DC or in AC peak value)	
Common mode rejection ratio (CMRR)	No less than 120 dB for frequencies DC - 60 Hz	
Frequency characteristics	Within the range of +0.5 dB and -3 dB for frequency range of DC - 40 kHz	
Low pass filter	Three-pole Bessel type: 1Hz, 30Hz, 500Hz, 5kHz and OFF Attenuation characteristics: -18 dB/oct.	
Temperature stability characteristics	For the use of units as temperature amplifiers:	
	Range:	within $\pm 0.04\%$ -FS/ $^\circ\text{C}$
	For the use of units as DC amplifiers:	
Zero point:	within $\pm 0.03\%$ -FS/ $^\circ\text{C}$	
Range:	within $\pm 0.01\%$ -FS/ $^\circ\text{C}$	
A/D conversion characteristics	Resolution	15 bits
	Conversion time	10 $\mu\text{s}$ max.
	Conversion method	serial comparison method
Input connector	Terminal base: M4	
Withstand voltage	1.5 kV AC for one minute between input terminal and ground, and between channels.	
S/N ratio	For use of units as DC amplifiers: -52 dB or greater (at Wide Range) For use of units as thermocouple amplifiers: -60 dB or greater (at Wide Range, with 5kHz filter)	
Mass	About 240 g	

1.6.5. External drawings of 2ch TC·DC Amp Unit (TDC, Model AP11-106/106A)

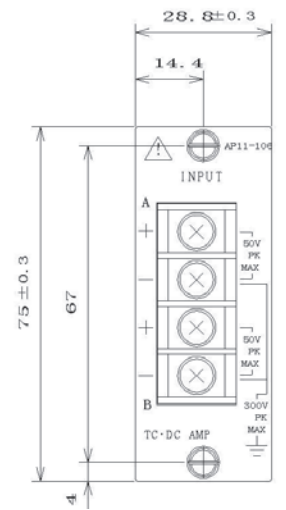
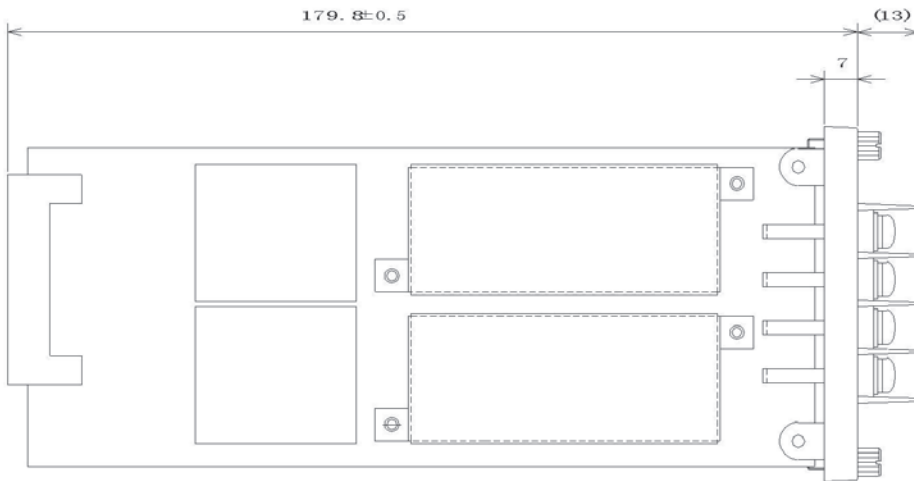
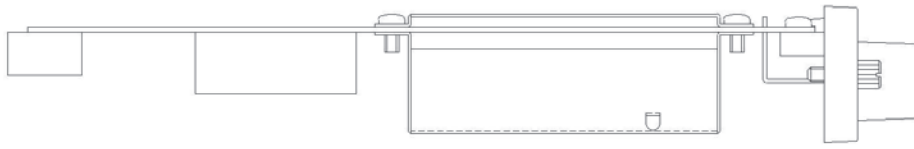

## 1.7. TC·DC Amp Unit (TDC, Model AP11-107)

The TC·DC Amp Unit is used to make temperature measurement by directly connecting thermocouples (R, T, J and K) to their input terminals. The units can also be used as high-sensitivity DC amplifiers.

### 1.7.1. Connection with input signals

Positive + (plus) side of input terminal (red)

High impedance side of thermocouple or signal source (i.e., H-side: hot side)

Negative –(minus) side of input terminal (black)

Low impedance side of thermocouple or signal source (i.e., L-side: low side)

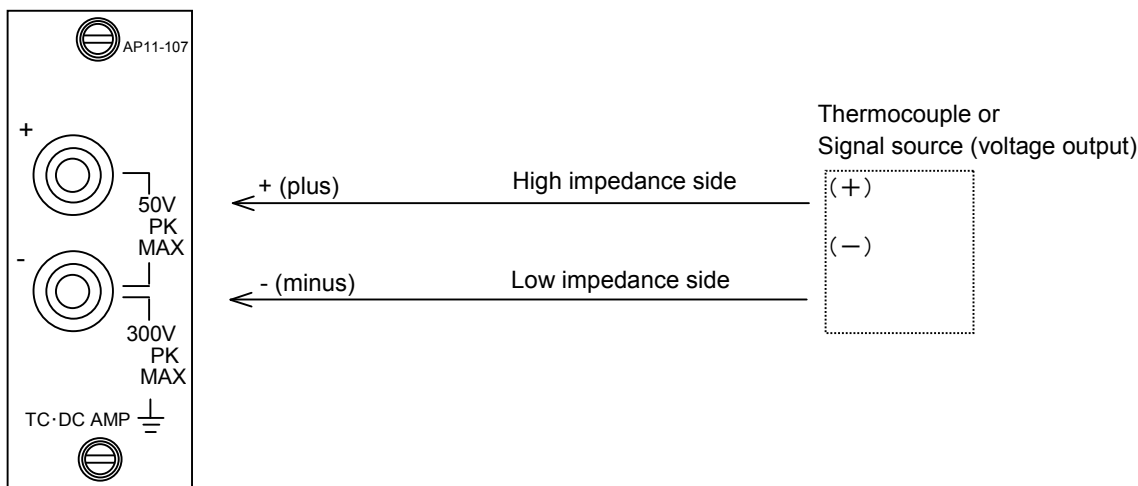

**NOTE**

- # Do not use unnecessarily long cables for input connection.
- # Use shielded cables for input connection to avoid electrostatic noise.
- # Twist the positive (+) and negative (-) lines of the input cable to avoid magnetic noise.
- # Please keep the signal source impedance as low as possible, i.e., less than 100 Ω.
- The lower the signal source impedance is, the higher the quality of measurement record is.

### ■ Notes and tips on the use of TC·DC Amp Unit:

TC·DC (temperature/voltage) Amp Unit can also be used as DC Amp.

The following describes some notes and tips on the use of TC·DC Amp unit as temperature amplifiers and as DC amplifiers:

- **Use of TC·DC Amp Unit as temperature amplifiers:**



- # Directly connect the original raw wire or the compensation conductor of a thermocouple to the input terminal of the unit. Instead, you may use a crimping terminal (6 mm in diameter) with low heat capacity at the unit input terminal.
- # Connect a thermocouple to the input terminal particularly paying attention to the correctness of its polarity. If wrong connection in polarity is made for a thermocouple at the unit input terminal, the recorded temperature will be lower than the actual temperature.
- # When a thermocouple is directly connected to the unit input terminal, set an internal temperature compensation with a reference contact.
- # When a temperature compensation with a reference contact is set externally, you will also need an external temperature compensation for the reference contact such as a zero-control scheme.
- # Start your measurement at least 30 minutes after switching the power on, providing sufficient time period of equipment warm-up, so that stable measurement can be made.
- # Make temperature measurement at least about 10 minutes after thermocouples have been connected.



- # Accurate measurement cannot be made due to temperature gradient at the terminal section if the input terminal is directly hit by a hot wind or a cold wind. To cope with such a situation, put an enclosure around the input terminal.
- # When the unit is used as a temperature amplifier, the unit is not suitable to record signals in general (i.e., voltage measurement), since a built-in linearizer is connected to the circuit. In this case, set at "Measure with V"

● Use of TC·DC Amp unit as DC amplifiers:



# Permissible input voltage:  
If you apply, by error, any voltages that are more than the permissible input voltage  $\pm 50V$  (in DC or in AC peak value), equipment failures would be induced due to breakdown of internal parts or other reasons. Do not apply input voltages exceeding the permissible input voltage.

# Input impedance  
The input impedance in the voltage input mode is approximately ten (10)  $M\Omega$  at the ranges 100mV - 2V-FS, and is approximately one (1)  $M\Omega$  at the ranges 5 - 50V-FS. However, note that the input impedance will be lowered to approximately 5 or 6  $k\Omega$  at minimum, when the input voltage exceeds  $\pm 6 V$  (in DC or in AC peak value).

● Common notes and tips:



- # Use the unit by confirming the permissible common mode input voltages (CMV) to be no more than  $\pm 300 V$  (in DC or in AC peak value).
- # Use such cables that have insulation sheath with no less than 2kV of withstand voltages.
- # Do not apply voltages exceeding the permissible common mode input voltage, since application of such voltages would lead to malfunctions or failures of equipment. Also, note that recorded waveforms may involve noise components due to degradation of common mode rejection ratio (CMRR), when noise-like impulsive common mode voltages are applied.



The sample speed must be set at 10 $\mu s$  steps, otherwise the signal waveform cannot be obtained correctly.  
Example : 5  $\mu s$  or 11  $\mu s$ , etc. makes the waveform distort.

1.7.2. Kinds of thermocouple and the characteristics

	Advantages	Disadvantages
K	Good linearity of electromotive force. Suitable to oxidized atmosphere.	Weak for reducing atmosphere. High electric resistance.
J	Cheaper than K thermocouple. High sensitivity. Nonmagnetic.	Weak for reducing atmosphere. High electric resistance.
T	Cheap and easy to get. Good low temperature characteristics. Suitable to reducing atmosphere.	Maximum operating temperature is low. Heat-conductive error is large.
R	High accuracy. Unevenness and deterioration are little. Good chemical resistance and oxidation resistance. Useable as standard.	No good linearity of electromotive force. Weak for reducing atmosphere. Impossible to measure lower temperature than 0 °C.

### 1.7.3. How to set TC·DC Amp Unit (TDC, Model AP11-107)

This section covers operation in the Amp Basic screen that appears when the Amp button on the operation panel is pressed and the Amp Detailed screen that appears when a channel button is pressed.

The displayed contents are the same as those in Celsius temperature measurement mode as shown below.

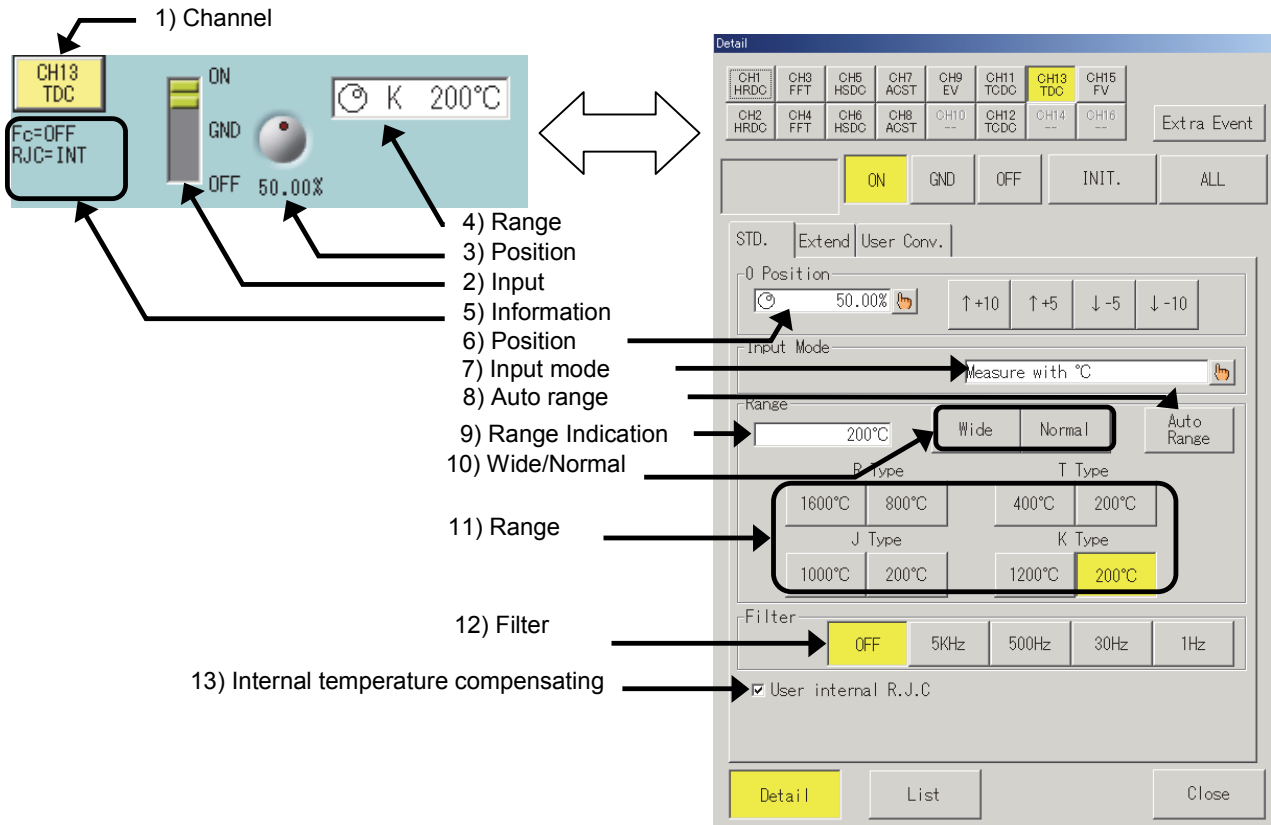

- 1) Basics - Channel  
The channel number, input amp unit type, and waveform color are indicated in this portion. Pressing this button displays the Amp Detailed screen.
- 2) Basics - Input  
Input mode can be selected. Pressing this button permits switching among ON, GND, and OFF.
- 3) Basic - Position  
This button is used to set the zero position. Pressing this button changes the button appearance. The setup can be made with the jog dial.
- 4) Basic - Range  
This button is used to set the range. Pressing the button changes the button appearance, and the setup can be made with the jog dial. The displayed contents are the same as those in the voltage measurement mode. That is, the contents are different from those for the vibration measurement mode.
- 5) Basic – Information indication  
This portion indicates the settings that are unable to be set on this screen. When changing the settings, make the settings in the Amp Detailed screen.  
Fc: Filter setting  
RJC: Reference Junction select setting

## 6) Details - Position

The zero position (base line) is set with a button. The zero position means the waveform display position at 0V input (input short). The base line can be set in 5% steps in reference to 100% as the full scale. Also, you can set it with the jog dial by pressing the jog button, or set it from the numeric input window by pressing the window button. And the position change is available through the setup of Physical Unit Conversion or Printing/Display Range. For more information, see Chapter 4. Physical Unit Conversion - Changing Printing/Display Range.

## 7) Details – Input mode

This button is used to set the measurement mode of input signal. The change of range contents can be made to set input mode. When the voltage measurement is set, the temperature compensation setting will be invalid.

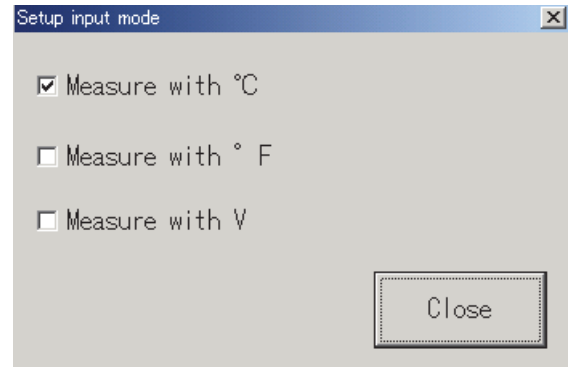

## 8) Details – Auto range

This button is automatically set the range adjustment corresponding to input signal.

## 9) Details – Range indication

The value of the current display range is displayed.

"#" is displayed when selecting the "Wide" range or changing "Printing / Display Range". After that, if you select the "Normal" range, the setting of "Printing / Display Range" is cleared and "#" disappears.

Also, when checking "Set EU." on the "User Conv." Tab and setting to use physical unit conversion, the full scale converted value will be displayed with \*.

For more information on physical unit conversion and printing / display range setting, see Chapter 4. Physical Unit Conversion - Changing Printing / Display Range.

## 10) Details – Wide/Normal

Wide: Entire measuring range is displayed.

Normal: Half of measuring range is displayed (Default).

## 11) Details - Range

The range can be directly set.

The change of range contents can be made to set input mode.

**TIPS**

When the measurement range is changed, the waveform clip range is cleared to the default value corresponding to the new range.

## 12) Details - Filter

Value for the low-pass filter can be set.

## 13) Details – Internal temperature compensation

The reference contact temperature compensation is made internally or externally. When the thermocouple is directly connected, tick this box (default). If using a zero-temperature compensating device, do not tick this box. This setting is only valid when the input mode is in temperature measurement.

1.7.4. Specifications of TC·DC Amp Unit (TDC, Model AP11-107)

Number of channels	1 channel (ch)/unit	
Input mode	Unbalanced input (The channel in the unit is insulated from cabinet.)	
Input coupling mode	DC coupling	
Applicable thermocouples	R, T, J and K	
Measurement range	Use of units as thermocouple amplifiers: Range of temperature measurement	
	Range	Display in Celsius
	R800	800°C (0 - 800°C)
	R1600	1600°C (0 - 1600°C)
	T200	200°C (-200 - 200°C)
	T400	400°C (-200 - 400°C)
	J200	200°C (-200 - 200°C)
	J1000	1000°C (-200 - 1000°C)
	K200	200°C (-200 - 200°C)
	K1200	1200°C (-200 - 1200°C)
Equipped with fine adjustment capabilities in individual ranges		
Use of units as DC amplifiers 10mV-FS, 20mV-FS, 50mV-FS, 100mV-FS, 200mV-FS, 500mV-FS 1V-FS, 2V-FS, 5V-FS, 10V-FS, 20V-FS, 50V-FS Equipped with fine adjustment capabilities in individual ranges		
Accuracy	For the use of units as thermocouple amplifiers: within $\pm 0.5\%$ -FS Within $\pm 1\%$ -FS of -200 - 0°C for 200°C -FS range For the use of units as DC amplifiers: within $\pm 0.5\%$ -FS of range accuracy and within $\pm 0.1\%$ -FS of linearity	
Frequency characteristics	Within the range of +0.5 dB and -3 dB for frequency range of DC - 40 kHz	
Reference Junction	Switch able between internal and external compensation	
Offset accuracy	For the use of units as DC amplifiers: within $\pm 0.3\%$ -FS At 23°C of environment temperature of mainframe operation	
Input impedance	No less than 10 M $\Omega$ ※approximately 1M $\Omega$ for the ranges of 5, 10, 20 and 50V-FS for use as DC amplifiers	
Permissible input voltage	$\pm 50$ V (in DC or in AC peak value)	
Permissible common mode input voltage (CMV)	$\pm 300$ V (in DC or in AC peak value)	
Common mode rejection ratio (CMRR)	No less than 120 dB with shorted input for 60 Hz	
Compensation accuracy for Reference Junction	Within $\pm 2^\circ\text{C}$ of accuracy (at input terminal section temperature equilibrium) ※Within $\pm 1^\circ\text{C}$ of accuracy at 20°C (at input terminal section temperature equilibrium)	
Low pass filter	Three-pole Bessel type: 1Hz, 30Hz, 500Hz, 5kHz and OFF Attenuation characteristics: -18 dB/oct.	
Temperature stability characteristics	For the ranges of 800°C for R-type and of 200°C for K, T and J types of thermocouples:	
	Range	within $\pm 0.04\%$ -FS /°C
	For 10mV- FS range for DC amplifiers:	
Zero point	within $\pm 0.03\%$ -FS /°C	
Range	within $\pm 0.01\%$ -FS /°C	
A/D conversion characteristics	Resolution	14 bits
	Conversion time	10 $\mu\text{s}$ max.
	Conversion method	Serial comparison method
Input connector	2 Terminals	
Withstand voltage	1.5 kV AC for one minute between input terminal and ground	
S/N ratio	For use of units as DC amplifiers: -46 dB or greater (at Wide Range) For use of units as thermocouple amplifiers: -60 dB or greater (at Wide Range, with 5kHz filter)	
Mass	About 200 g	

1.7.5. External drawings of TC·DC Amp Unit (TDC, Model AP11-107)

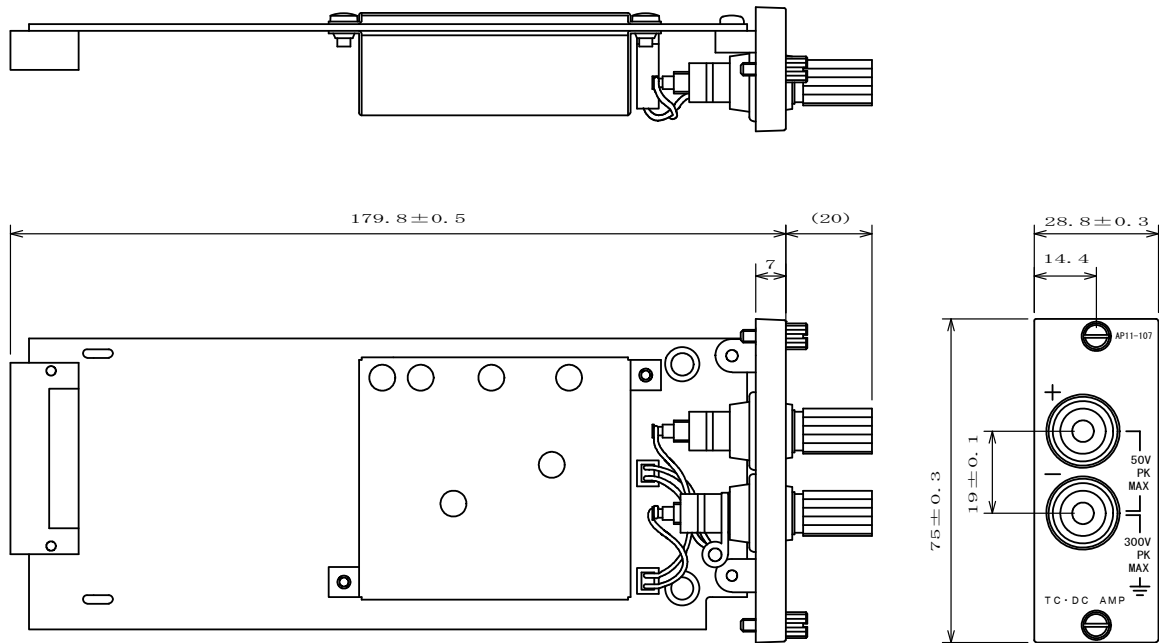

## 1.8. F/V Converter Unit (FV, Model AP11-108)

F/V converters are used to convert input signal frequencies into analog voltages.



Application of voltages of more than 100V (in DC or in AC peak value) to the input of those units will lead to equipment failure. Use F/V converter units always at voltages no more than 100V (in DC or in AC peak values).

### 1.8.1. Connection with input signals

#### ■ Connection instructions

It is very important to correctly connect input circuits to make accurate measurement with low noise level. Basically, connect input circuits as shown in the following:

# Positive (+ or plus) side of BNC connector

←high impedance side of signal source (i.e., H-side: hot side)

# Negative (- or minus) side BNC connector

←low impedance side of signal source (i.e., L-side: low side)

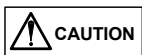
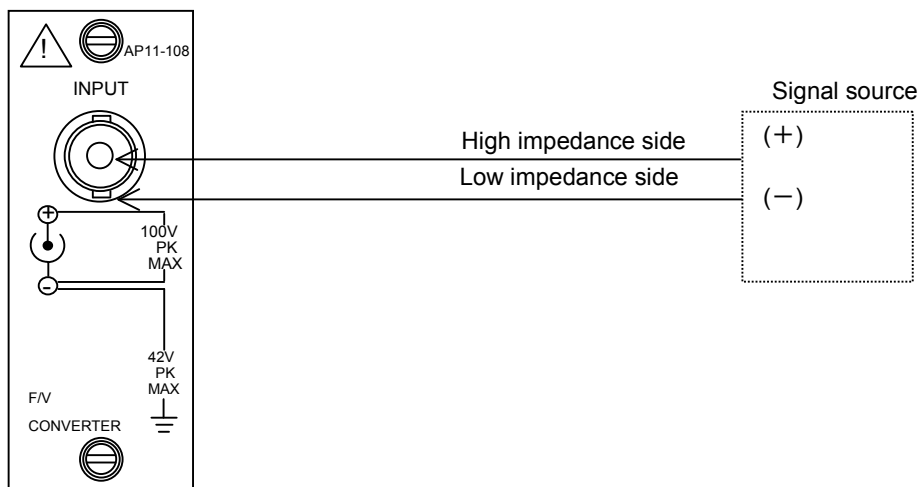

Please pay attention to the following points when you want to record low level signals  
 # Do not use unnecessarily long cables for input connection  
 # Use shielded cables for input connection to avoid electrostatic noise

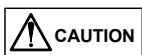

Please keep the signal source impedance as low as possible, i.e., less than 100 Ω. From the point of view of noise contribution, the lower the signal source impedance is, the higher the quality of measurement record is.



Use the unit at the common mode voltage (CMV) that is no more than 300 V (in DC or in AC peak voltage), when the signal source is not grounded. Use such cables that have insulation sheath with withstand voltages of no less than 2 kV.



Use by all means insulated BNC cables (optional item: input signal cables 0311-5175, with a BNC connector and test clips, of 2 m long) for input connection. The outer shells of metal type BNC connectors have the negative (-) polarity potential of the input signal. Therefore, you would suffer an electric shock by touching the outer shell while the cable is connected to a signal source. Thus, note that it is very dangerous for you to touch it.

If you need to use a BNC connector of the metal type due to some unavoidable circumstances, confirm that the common mode input voltage is within the range of ±42 V (in DC or in AC peak value) through carrying out appropriate examination of the signal source.

Also, some metal type BNC cables may cause mating problems. Insulation BNC sockets may crack if they are forcibly connected, so please do not use what cannot be mated smoothly.

## ■ Input signals



### Maximum input voltage

The maximum permissible input voltage is 100 V (in DC or in AC peak values). If you apply, by error, an input voltage exceeding 100 V (in DC or in AC peak value), this will lead to equipment failure caused by breakdown of parts that are used internal to the unit.



### Permissible common mode input voltage (CMV)

Use insulated BNC cables for input connection by all means, which may be attached as an optional item. Be careful to maintain the common mode input voltage (CMV) at no more than  $\pm 300\text{V}$  (in DC or in AC peak value).

Also, note that input frequencies may not always be correctly converted to analog values due to degradation of common mode rejection ratio (CMRR), when noise-like impulsive common mode voltages are applied.

Do not apply input voltages exceeding the specified permissible common mode input voltage of 300 V, peak value. This is because application of such voltages would lead to malfunctions of equipment.



### Ranges of operational input voltages and frequencies

Be careful that measurement results will involve errors if you apply input voltages that are outside the frequency range of 0.3 - 30 V, peak-to-peak.

Also, note that the specified input frequency range is 1 Hz - 10 kHz.



Detection of the input frequency is done at the instant the input signal pass through the trigger level. Therefore, the input waveform should always to be fluctuating around the voltage level of approximately 0.1 V to perform frequency measurement.

### NOTE

### Input impedance

The input impedance is always 100 k $\Omega$  approximately.

# Maintain the input voltages within the range of -12V - +12V when using the equipment.

# Normal and correct measurement cannot be expected if the input voltage exceeds the range above.

### 1.8.2. How to set F/V Converter Unit (FV, Model AP11-108)

This section covers operations in the Amp Basic screen that appears when the Amp button on the operation panel is pressed and the Amp Details screen that appears when a channel button is pressed.

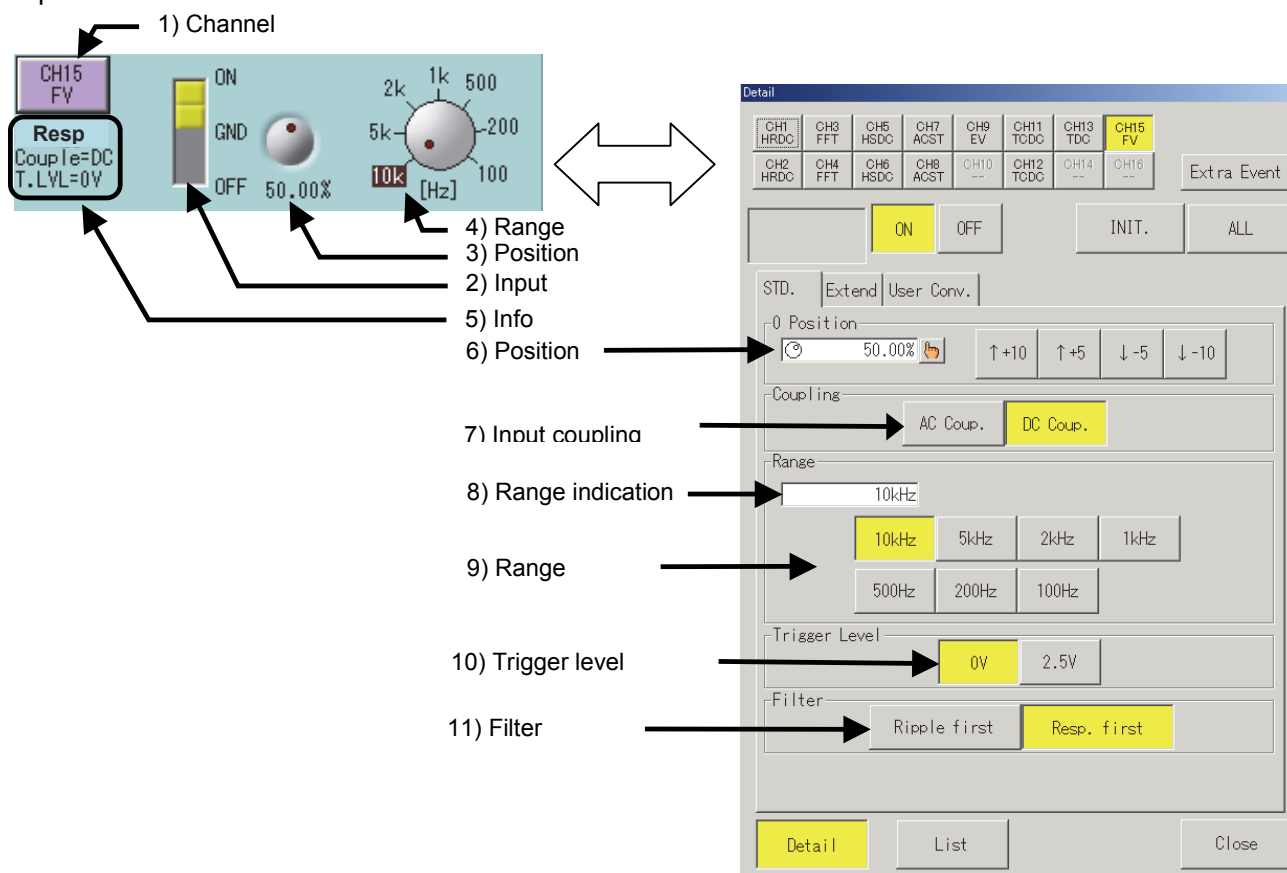

- 1) Basics - Channel  
The channel number, input amp unit type, and waveform color are indicated in this portion. Pressing this button displays the Amp Details screen.
- 2) Basics - Input  
Input mode can be selected. Pressing this button permits switching among ON, GND, and OFF.
- 3) Basics - Position  
This button is used to set the zero position. Pressing this button changes the button appearance. The setup can be made with the jog dial.
- 4) Basics - Range  
This button is used to set the range. Pressing this button changes the button appearance. The setup can be made with the jog dial.
- 5) Basics - Information indication  
This portion indicates settings that are unable to be set on this screen. When changing the settings, make the settings in the Amp Details Screen.  
  - FILT: Filter setting (Ripple/Resp)
  - Couple: Input coupling setting (DC/AC)
  - TRIG: Trigger level setting (0 V/2.5 V)
- 6) Details - Position  
The zero position (base line) is set with a button. The zero position means the waveform display position at 0V input (input short). The base line can be set in 5% steps in reference to 100% as the full scale. Also, you can set it with the jog dial by pressing the jog button, or set it from the numeric input window by pressing the window button. And the position change is available through the setup of Physical Unit Conversion or Printing/Display Range. For more information, see Chapter 4. Physical Unit Conversion - Changing Printing/Display Range.



7) Details – Input Coupling

The input coupling is set by pressing the AC coupling button or DC coupling button.

**TIPS**

When the AC coupling button is pressed, a capacitor is connected to the input terminal. The DC element can be eliminated, which enables the measurement of alternating voltage.

8) Details - Range indication

The value of the current display range is displayed.

"#" is displayed when selecting the "Wide" range or changing "Printing / Display Range". After that, if you select the "Normal" range, the setting of "Printing / Display Range" is cleared and "#" disappears.

Also, when checking "Set EU." on the "User Conv." Tab and setting to use physical unit conversion, the full scale converted value will be displayed with \*.

For more information on physical unit conversion and printing / display range setting, see Chapter 4. Physical Unit Conversion - Changing Printing / Display Range.

9) Details - Range

Range can be directly set.

**TIPS**

When the measurement range is changed, the waveform clip range is cleared to the default value corresponding to the new range.

10) Details - Trigger level

This unit detects the rising edge of the input signal to convert data of the frequency.

The voltage level for this detection can be changed. The default value is 0V.

11) Details - Filter

This unit can select the filter mode from among the following two modes:

Mode	Description
Ripple first	The ripple ratio (approx. 0.5% or less) is prioritized.
Response first	The response time is prioritized.

1.8.3. Ripple ratio and response time

■ **Ripple ratio**

Ripples are defined as a type of waveform like wavelets that are contained in the output signal.

The ripple ratio is defined as a percentage % with respect to the full scale.

The magnitude of ripples depends on the frequency of the input signal.

■ **Response time**

The response time is defined as the time period that the output signal reaches 90% from 10% of the full scale when the input signal produces the full scale input in the stable condition.

(e.g., time period that the output signal reaches 9 kHz from 1 kHz for the range of 10 kHz-FS (full scale)).

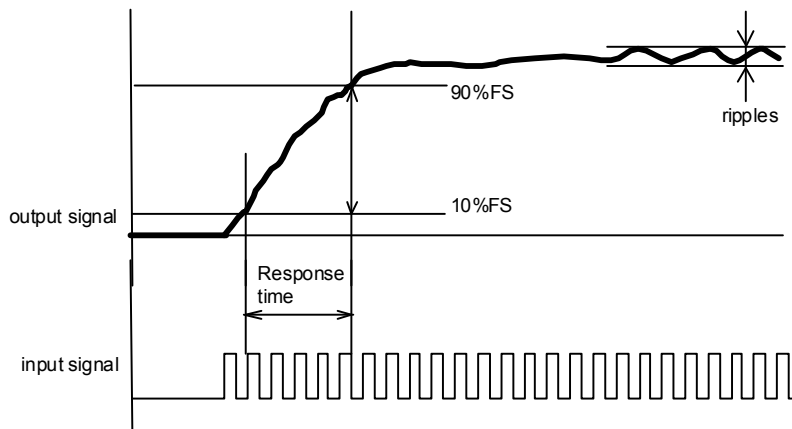

## 1.8.4. Specifications of F/V Converter Unit (FV, Model AP11-108)

Number of channels	1 channel (CH)/unit				
Input mode	Unbalanced input (The channel is insulated from cabinet.)				
Input coupling modes	AC coupling and DC coupling				
Input frequency range	1 Hz - 10 kHz				
Triggering level	Selectable between about 0V or about 2.5V				
Input pulse width	No less than 20 $\mu$ s				
Sensitivity and Accuracy	Input range	100, 200, 500, 1k, 2k, 5k and 10kHz-FS (seven ranges in all)			
	Accuracy	Within $\pm 0.5\%$ -FS			
Offset accuracy	Within $\pm 0.5\%$ -FS <b>*at 25 °C of environment temperature of mainframe operation</b>				
Input impedance	No less than 100 k $\Omega$				
Permissible input voltage	$\pm 100$ V(in DC or in AC peak value)				
Permissible common mode input voltage (CMV)	$\pm 42$ V (in DC or in AC peak value) for an amplifier unit only. <b>*300 VAC when an insulated BNC cable (signal cable 0311-5175) is used.</b>				
Linearity	Within $\pm 0.3\%$ -FS				
Response time and ripples	Zero point: within $\pm 0.03\%$ -FS/ $^{\circ}$ C Range: within $\pm 0.02\%$ -FS/ $^{\circ}$ C				
Response time and ripples	When "Ripple first" is selected, ripples are automatically set/controlled so that the ripple ratio is confined to within 0.5%-FS. When "Resp. first" is selected, the response time is automatically set/controlled to be the shortest.				
		Ripple first		Resp. first	
	Range Hz-FS	Response time	Ripples	Response time	Ripples
	100	315~473ms	Within 0.5%-FS	80~130 ms	Within 3%-FS
	200	170~255ms	Within 0.5%-FS	40~62 ms	Within 3%-FS
	500	75~115ms	Within 0.5%-FS	16~24.5 ms	Within 2%-FS
	1k	50~76.5ms	Within 0.5%-FS	9.0~14 ms	Within 2%-FS
	2k	42~62ms	Within 0.5%-FS	5.5~8.5 ms	Within 1%-FS
	5k	9.0~14ms	Within 0.5%-FS	4.0~6.5 ms	Within 1%-FS
10k	5.0~7.6ms	Within 0.5%-FS	1.0~2.0 ms	Within 1%-FS	
Response time: time period required for a waveform to reach 90% from 10% of the full scale					
A/D conversion characteristics	Resolution	16 bits			
	Conversion time	10 $\mu$ s max			
	Conversion method	Serial comparison method			
Input connector	Insulated connector of the BNC type				
Withstand voltage	1.5 kV AC for one minute between input terminal and ground.				
Mass	About 125 g				

1.8.5. External drawings of F/V Converter Unit (FV, Model AP11-108)

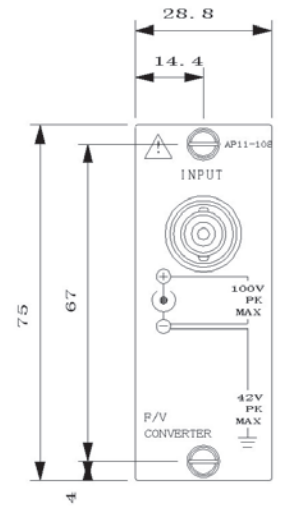
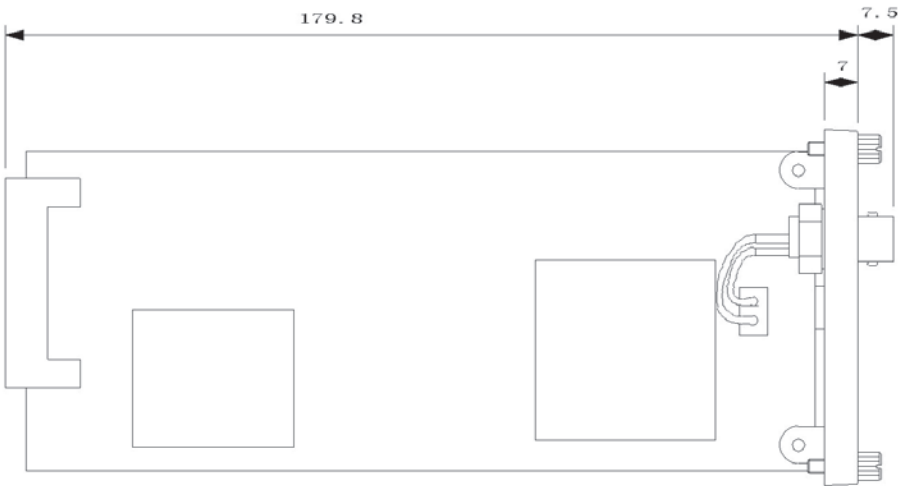

## 1.9. 2ch Vibration & RMS Amp Unit (RMS, Model AP11-109)

The 2ch Vibration & RMS amplifier units have dual capabilities of A/D-converting output voltages of piezoelectric acceleration sensors built-in the amplifier and of A/D-converting the root-mean-square value of input voltages. The units incorporate two (2) channels per unit and the two channels are insulated to each other within the unit.



Application to this unit of voltages exceeding the permissible input voltages specified below will lead to equipment failure. Maintain the input voltages not exceeding the permissible voltages at all times.

Permissible input voltages (DC or AC peak value)	Input Ranges	
	RMS mode	DC mode
100 V	0.1 - 1 V <sub>rms</sub> -FS	0.1 - 5 V-FS
500 V	2 - 350 V <sub>rms</sub> -FS	10 - 500 V-FS

### 1.9.1. Connection with input signals

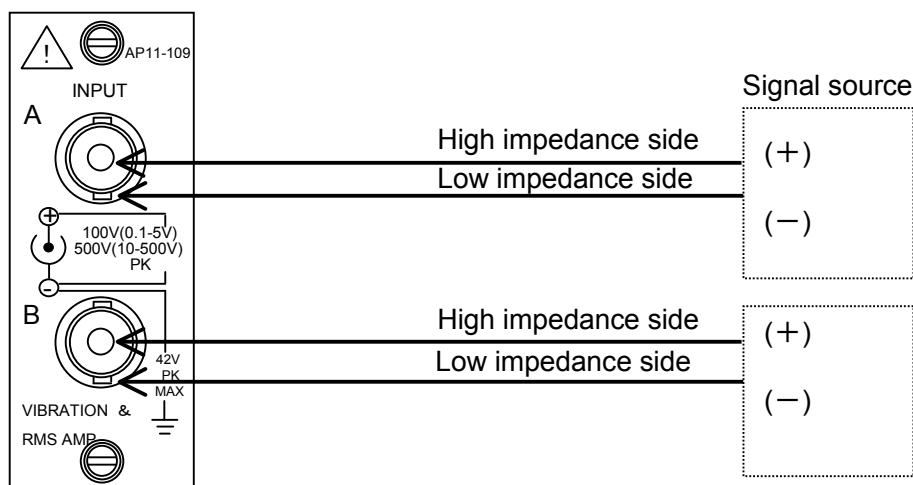

Use by all means insulated BNC cables (optional item: input signal cables 0311-5175, with a BNC connector and test clips, of 2 m long) for input connection.

The outer shells of metal type BNC connectors have the negative (-) polarity potential of the input signal. Therefore, you would suffer an electric shock by touching the outer shell while the cable is connected to a signal source. Thus, note that it is very dangerous for you to touch it.

If you need to use a BNC connector of the metal type due to some unavoidable circumstances, confirm that the common mode input voltage is within the range of  $\pm 42$  V (in DC or in AC peak value) through carrying out appropriate examination of the signal source.

Also, some metal type BNC cables may cause mating problems. Insulated BNC sockets may crack if they are forcibly connected, so please do not use what cannot be mated smoothly.

#### NOTE

Please pay attention to the following points when you want to record low level signals:

- # Do not use unnecessarily long cables for input connection
- # Use shielded cables for input connection to avoid electrostatic noise

Please keep the signal source impedance as low as possible, i.e., less than 100  $\Omega$ . The lower the signal source impedance is, the higher the quality of measurement record is.

## ■ Input Signals



### Permissible input voltages

If a voltage higher than the rated voltage is input, this unit may be damaged due to internal damage such as component breakdown. Make sure that the input voltage does not exceed the following permissible input voltage for each input range.

Sensitivity ranges (V in FS)	0.1, 0.2, 0.5, 1, 2, 5	10, 20, 50, 100, 200, 500
Permissible input voltages (V)	100 V	500 V



### Input impedance

The input impedance is approximately one (1) M $\Omega$ . However, note that the input impedance will be lowered to approximately 15 k $\Omega$ , when the input voltage becomes  $\pm 8$  V or more for the input sensitivity ranges of 0.1 - 5 V-FS (full-scale) in the DC coupling mode.



### Permissible common mode input voltages (CMV)

Use the insulated BNC cable, an optional item. In this case, confirm that the permissible common mode input voltage is no more than  $\pm 300$  V in DC or in AC peak value.



In the vibration mode and the vibration RMS mode, a constant-current of 2 mA is fed into the load from the input connector of the amplifier unit. (Voltages of more than 18 V can be exhibited at the connector.)

Do not connect any sensors other than the types of sensors that are specified for the use with this amplifier. Otherwise, the sensors may be damaged.

In the vibration mode, do not apply voltages. Application of voltages of  $\pm 30$  V or more at the input would induce amplifier failures.

### NOTE

Use cables having the insulation sheath of no less than 2 kV of withstand voltages.

Do not apply voltages exceeding the permissible common mode input voltage, since application of such voltages would lead to malfunctions or failures of equipment. Also, note that recordings may involve noise components due to degradation of common mode rejection ratio (CMRR), when noise-like impulsive common mode voltages are applied.

### NOTE

Use the equipment through keeping the input voltage within the range of -30V - +30V including the DC component, when the sensitivity range is one of 0.1 - 5 V-FS in the AC coupling mode.

Note that correct measurement cannot be expected when the input voltage exceeds the voltage range mentioned above.

### NOTE

The sampling speed must be set at 10 $\mu$ s steps, otherwise the signal waveform cannot be obtained correctly.

Example: 5  $\mu$ s or 11  $\mu$ s, etc. makes the waveform distort.

### 1.9.2. How to set RMS converter Mode of 2ch Vibration & RMS Amp Unit (RMS, Model AP11-109)

This section covers operations in the Amp Basic screen that appears when the Amp button on the operation panel is pressed and the Amp Details screen that appears when a channel button is pressed.

The following figure shows the display of the Vibration & RMS Amp in the RMS converter mode. For the Vibration sensor mode, see 1.9.3 How to set Input Mode (Voltage measurement/ RMS converter/ Vibration sensor/ Vibration, RMS output) and switch to the RMS converter mode.

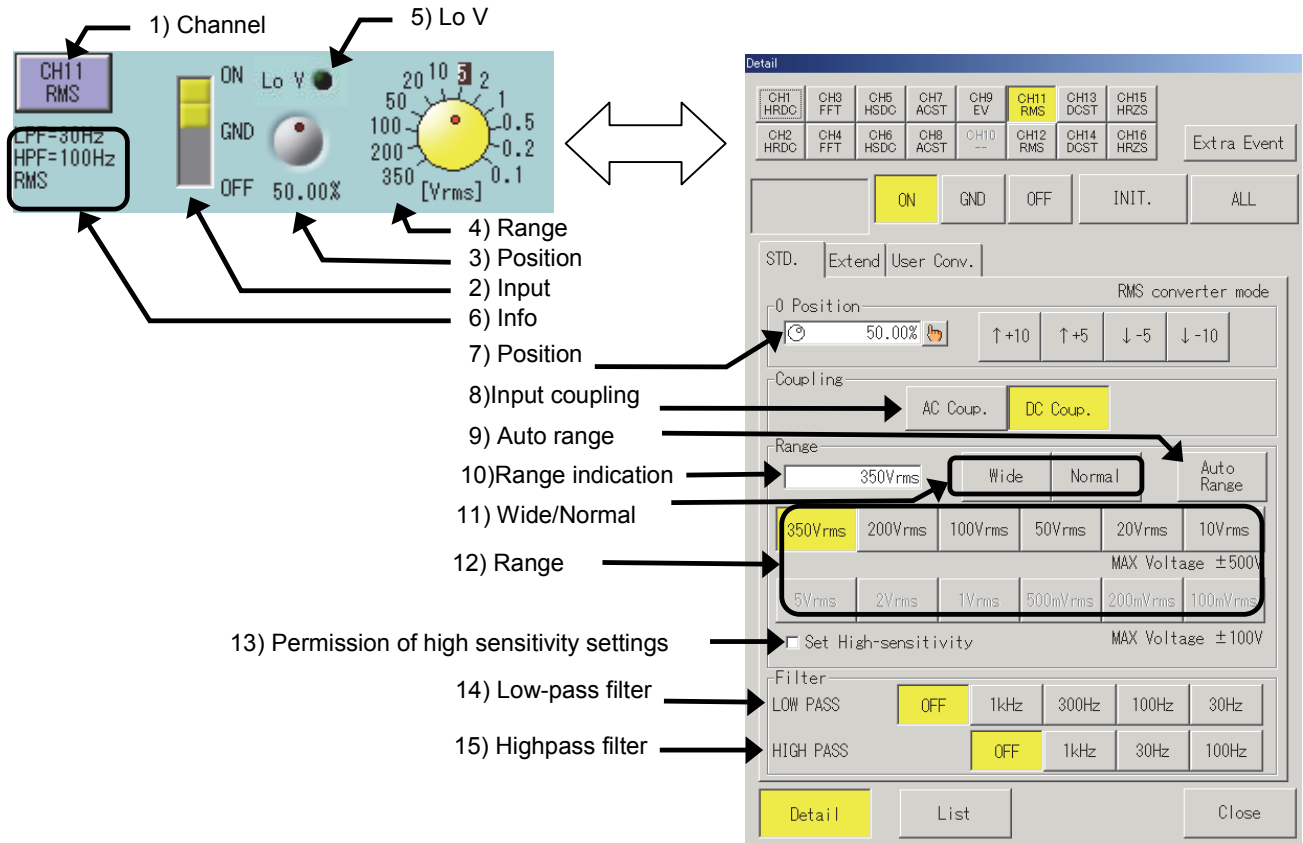

- 1) Basics - Channel  
The channel number, input amp unit type, and waveform color are indicated in this portion. Pressing this button displays the Amp Details screen.
- 2) Basics - Input  
Input mode can be selected. Pressing this button permits switching among ON, GND, and OFF.
- 3) Basics - Position  
This button is used to set the zero position. Pressing this button changes the button appearance. The setup can be made with the jog dial.
- 4) Basics - Range  
This button is used to set the range. Pressing this button changes the button appearance. The setup can be made with the jog dial. The displayed contents are the same as those in the voltage measurement mode. That is, the contents are different from those for the vibration measurement mode.
- 5) Basics – Lo V  
The LED lights if the high sensitivity range can be permitted.

- 6) Basics - Information indication  
This portion indicates settings that are unable to be set on this screen. When changing the settings, make the settings in the Amp Details screen.  
LPF: Low Pass Filter setting  
HPF: High Pass Filter setting  
Input Mode setting (DC/RMS/Vibration)
- 7) Details - Position  
The zero position (base line) is set with a button. The zero position means the waveform display position at 0V input (input short). The base line can be set in 5% steps in reference to 100% as the full scale. Also, you can set it with the jog dial by pressing the jog button, or set it from the numeric input window by pressing the window button. And the position change is available through the setup of Physical Unit Conversion or Printing/Display Range. For more information, see Chapter 4. Physical Unit Conversion – Changing Printing/Display Range.
- 8) Details – Input coupling  
The input coupling is set by pressing the AC coupling button or DC coupling button.

**TIPS**

When the AC coupling button is pressed, a capacitor is connected to the input terminal. The DC component can be eliminated, which enables the measurement of alternating voltage.

- 9) Details - Auto range  
The range is automatically adjusted to the input signal.
- 10) Details - Range indication  
The value of the current display range is displayed.  
"#" is displayed when selecting the "Wide" range or changing "Printing / Display Range". After that, if you select the "Normal" range, the setting of "Printing / Display Range" is cleared and "#" disappears.  
Also, when checking "Set EU." on the "User Conv." Tab and setting to use physical unit conversion, the full scale converted value will be displayed with \*.  
For more information on physical unit conversion and printing / display range setting, see Chapter 4. Physical Unit Conversion - Changing Printing / Display Range.
- 11) Details - Wide/Normal  
Wide: Entire measuring range is displayed.  
Normal: Half of the measuring range is displayed (Default).
- 12) Details – Range  
Range can be directly set.

**TIPS**

When the measurement range is changed, the waveform clip range is cleared to the default value corresponding to the new range.  
Example: During expansion of the waveform in the waveform clip range between +40 and -40 at 100 V, if the range is set to 100 V again, the waveform clip range is set to between +50 to -50 as the default. (Enlarged display is cancelled.)

**CAUTION**

Pay attention to the permissible input voltage when setting the range.  
See Permissible input voltages in "Input Signals".

- 13) Details - Permission of high sensitivity settings  
Settings to the high-sensitivity range (5 V to 100 mV) can be prohibited/permitted.  
When using the high-sensitivity range, check the check box.  
When the high-sensitivity range is not used, prohibition of the high-sensitivity range without checking the box is recommended for safety.
- 14) Details - Low-pass filter  
This button is used to set the low-pass filter.
- 15) Details - High-pass filter  
This button is used to set the high-pass filter.

### 1.9.3. How to set Input Mode (Voltage measurement/ RMS converter/ Vibration sensor/ Vibration, RMS output)

The target for measuring can be changed by switching the input mode of the Vibration & RMS Amp. Pressing the Input mode button in the Expansion tab in the Amp Details screen of the Vibration & RMS Amp displays the following screen, which allows changing the input mode.

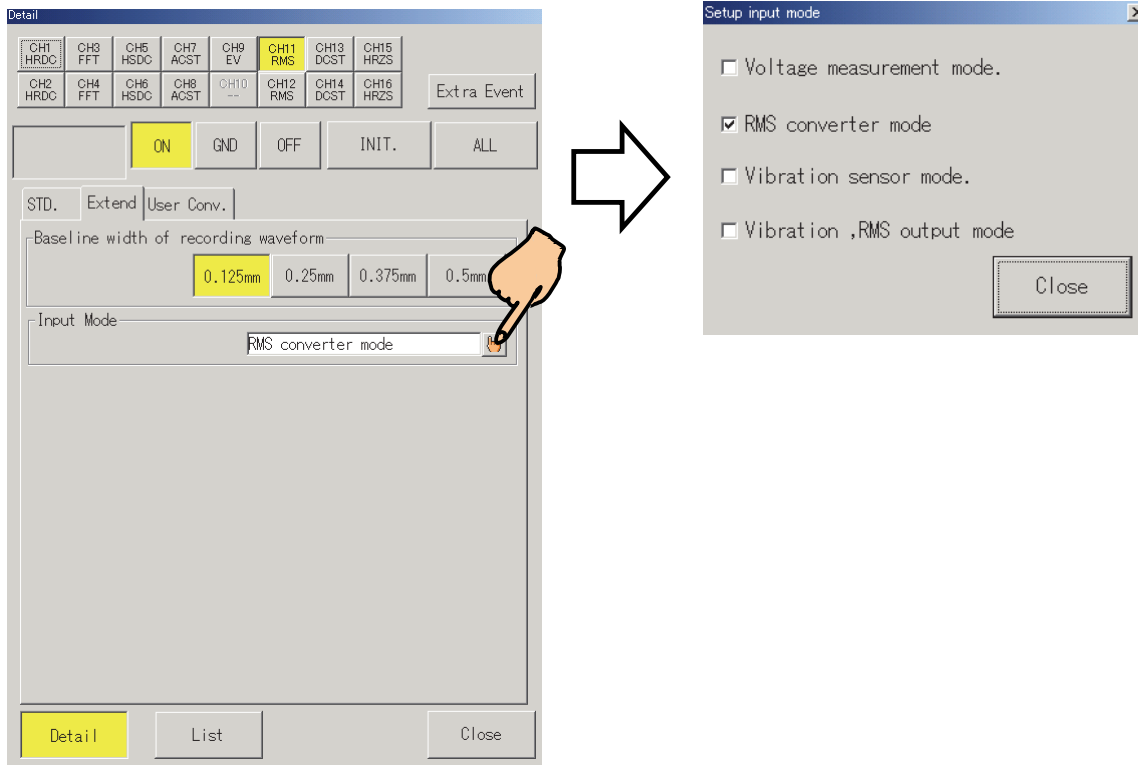

**NOTE**

In the vibration sensor mode, a constant-current is independently required for the sensor. Therefore, if any units other than the vibration sensor are connected to the amp, a signal source may be damaged. Confirm the connection at the amp input port before switching to the vibration sensor mode.



### 1.9.4. How to set Vibration Sensor Mode of 2ch Vibration & RMS Amp Unit (RMS, Model AP11-109)

This section covers operations in the Amp Basic screen that appears when the Amp button on the operation panel is pressed and the Amp Details screen that appears when a channel button is pressed.

The following figure shows the display of the Vibration & RMS Amp in the vibration sensor mode. For the Voltage Measurement mode, see 1.9.3 How to set Input Mode (Voltage Measurement/ RMS converter/ Vibration Sensor/ Vibration, RMS output) and switch to the vibration sensor mode.

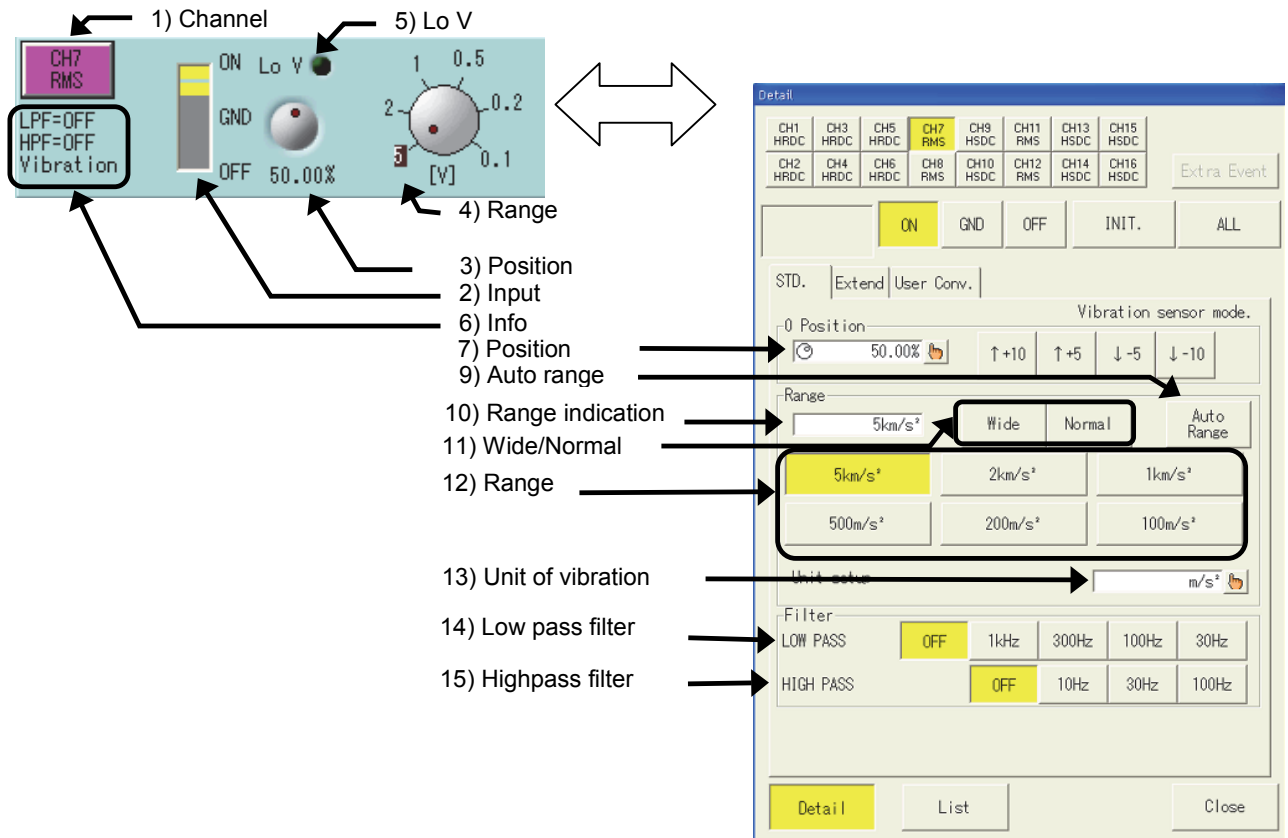

The procedure is the same as those in 1.9.2 How to set RMS converter mode of 2ch Vibration & RMS Amp Unit (RMS, Model AP11-109).

Operations of different portions are described hereafter:

- 4) Basics - Range  
The contents are different from those for the RMS converter mode. However, the operability is the same.
- 12) Details - Range  
Range can be directly set.  
The range values are indicated after calculated with the sensor sensitivity, converter sensitivity and unit of vibration.
- 13) Details - Unit of vibration  
The unit of the vibration system can be selected between units, m/s<sup>2</sup> and G.

#### TIPS

The result from the changed unit is reflected to the Range, Sensor sensitivity and Converter sensitivity.  
Before starting measurement, confirm the reflected parts.

### 1.9.5. How to set Vibration Sensor

In the vibration sensor mode, the sensor type can be selected between Built-in Amp sensor and piezoelectric sensor + Charge converter in the Sensor settings. Pressing the Sensor sensitivity button in the Expansion tab in the Amp Details screen of the Vibration & RMS Amp displays the following screen, which allows changing the input sensor type. Switching the sensor setting changes the setting screen for the sensor sensitivity.

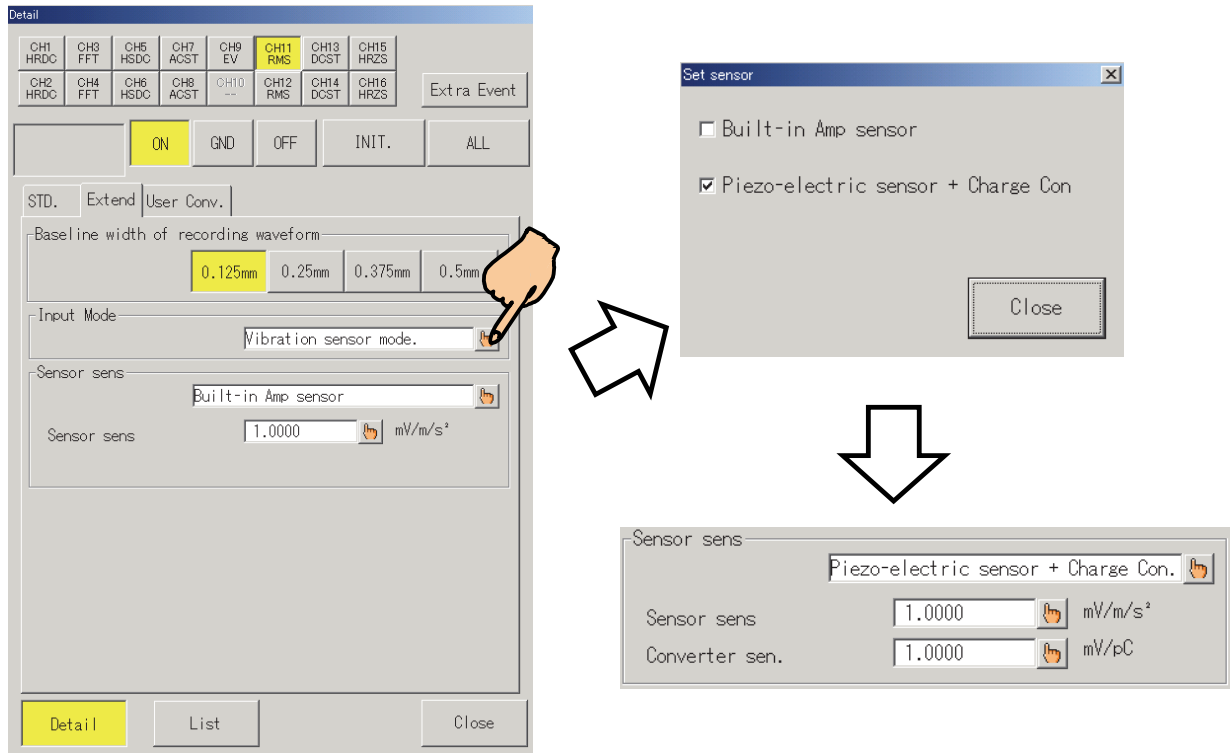

The following tables show the relation between range values by the sensor sensitivity settings.

- **Voltage range for Vibration measurement**

The following range is available as the voltage range for the vibration measurement:

5V	2V	1V	500 mV	200 mV	100 mV
----	----	----	--------	--------	--------

- **Built-in Amp sensor**

The range values vary depending on the sensor sensitivity settings.

The calculating formula of the vibration range is:

$$\text{Vibration range (m/s}^2\text{)} = \text{Voltage range (V)} \div \text{Sensor sensitivity (V/m/s}^2\text{)}$$

- **Piezoelectric sensor+ Charge Converter**

The vibration range values vary depending on the sensor sensitivity and converter sensitivity.

The calculating formula of the vibration range is:

$$\text{Vibration range (m/s}^2\text{)} = \text{Voltage range (V)} \div (\text{Sensor sensitivity (pC/m/s}^2\text{)} \times \text{Converter sensitivity (V/pC)})$$

- **Unit of vibration range**

The unit of vibration range is switched between [m/s<sup>2</sup>] and [G] depending on the unit of vibration.

### 1.9.6. Specifications of 2ch Vibration & RMS Amp Unit (RMS, Model AP11-109)

Number of channels	2 channels (chs)/unit	
Input mode	Unbalanced input (Each channel is insulated to each other within the unit and also is insulated from cabinet.)	
Input coupling modes	AC coupling and DC coupling	
Sensitivity and Accuracy	Input range	For Voltage measurement mode and for RMS converter mode: 0.1, 0.2, 0.5, 1, 2 and 5 V-FS ( $\pm 30V$ or less at AC coupling) 10, 20, 50, 100, 200 and 500 V-FS *The unit is $V_{rms}$ -FS for RMS converter mode. *For all range (i.e., $\pm 0.1 - \pm 500V$ -FS), wide-range is available. For Vibration sensor mode and for Vibration, RMS output mode: 5km/s <sup>2</sup> , 2km/s <sup>2</sup> , 1km/s <sup>2</sup> , 500m/s <sup>2</sup> , 200m/s <sup>2</sup> and 100m/s <sup>2</sup> -FS *The unit can also be set at G. *For all range, wide-range is available.
	Accuracy	Within $\pm 0.3\%$ -FS *Within $\pm 0.8\%$ -FS for 500 V-FS
Offset accuracy	Within $\pm 0.3\%$ -FS for use as DC amplifier *at 23 °C of environment temperature of mainframe operation	
Input impedance	No less than 1 M $\Omega$	
Permissible input voltage	$\pm 500V$ (DC or AC peak value) * $\pm 100V$ (DC or AC peak value) for input ranges of 0.1 - 5 V-FS	
Permissible common mode input voltage (CMV)	$\pm 42 V$ (DC or AC peak value) for an amplifier unit only *300 VAC when an insulated BNC cable (signal cable 0311-5175) is used	
Common mode rejection ratio (CMRR)	No less than 80 dB for frequencies DC - 60 Hz	
Frequency characteristics	For DC coupling: Within the range of +1 dB and -3 dB for frequency range of DC - 50 kHz For AC coupling: Within the range of +1 dB and -3 dB for frequency range of 1 Hz - 50 kHz	
Linearity	Within $\pm 0.1\%$ -FS	
Low pass filter	Four-pole Butterworth type: 30 Hz, 100 Hz, 300 Hz, 1 kHz and OFF (50 kHz) Attenuation characteristics: -24 dB/oct. approximately	
High pass filter	Four-pole Butterworth type: 10 Hz, 30 Hz, 100 Hz and OFF Attenuation characteristics: -24 dB/oct. approximately	
Sensor power supply	2 mA, 18 V or more	
RMS output capability	0.1, 0.2, 0.5, 1.0, 2.0, 5.0, 10, 20, 50, 100, 200 and 350 $V_{rms}$ -FS Accuracy: within $\pm 2\%$ -FS Crest factor: 5 max (except for ranges of 200 $V_{rms}$ -FS and 350 $V_{rms}$ -FS)	
Temperature stability characteristics	Zero point: within $\pm 0.02\%$ -FS/°C Range: within $\pm 0.01\%$ -FS/°C	
A/D conversion characteristics	Resolution	16 bits
	Conversion time	10 $\mu$ s max.
	Conversion method	Serial comparison method
Input connector	Insulation type BNC connector	
Withstand voltage	1.5 kV AC for one minute between input connector and ground, and between channels	
S/N ratio	-46 dB or greater (at the wide range setting)	
Mass	About 270 g	

1.9.7. External drawings of 2ch Vibration & RMS Amp Unit (RMS, Model AP11-109)

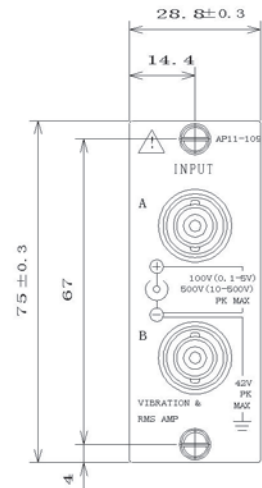
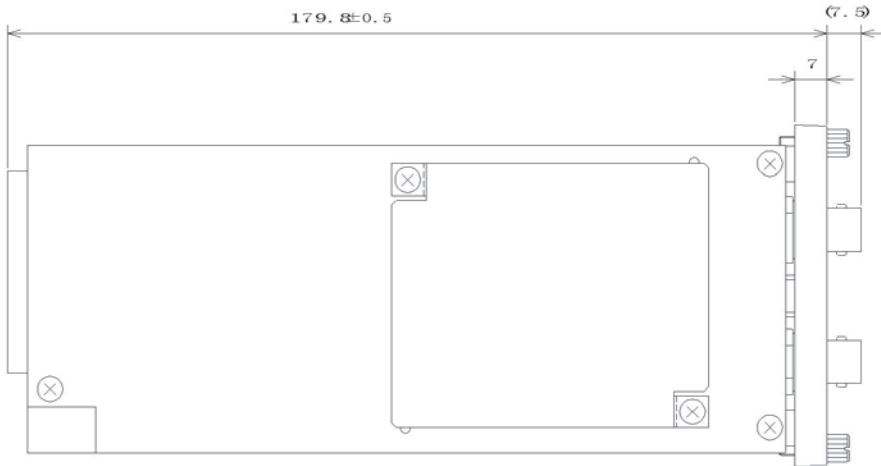
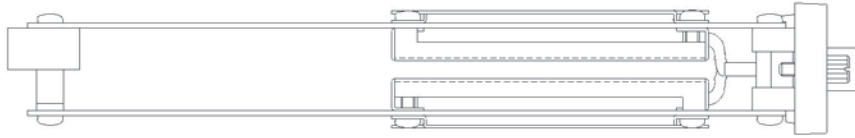

## 1.10. 2ch DC Strain Amp Unit (DCST, Model AP11-110)

The 2ch DC Strain Amp unit connects a strain gage type transducer and a bridge box connected with a strain gauge to the input and A / D converts its minute output signal to 16-bit high resolution data. The units incorporate two (2) channels per unit and the two channels are insulated to each other within the unit.

### 1.10.1. Connection with input signals

#### ■ Connection instructions

The diagrams/figures below show the input section of the 2ch DC Strain Amp unit.

Strain gauge type transducers or bridge boxes are connected to the input connector.

When the unit is used as a DC amplifier, the terminals of B (- input), D (+ input) and E (shield/ground), are used.

Use the cable (47228) dedicated to the connection of the unit.

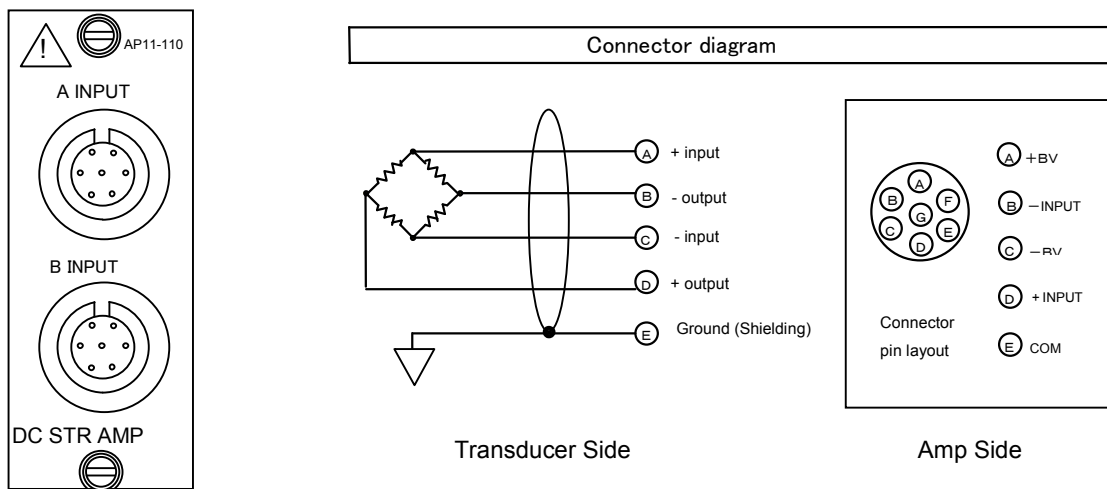

#### ■ Notes on the use of the transducers

Observe the following when you use the transducers:

##### NOTE

- # To tightly fix transducers at place by referring to the transducers instruction manual, since unstable fixation of the transducers will lead to equipment malfunctioning and/or noise generation.
- # To prevent transducers and connecting cables from rain, water, etc, while they are humidity resistant in general.
- # To use transducers that do not have connections between the ground (shield) terminal (E) and any of the other terminals (A, B, C and D) of this product.
- # Not to place transducers and connecting cables in the environment with high electric or magnetic field.
- # When the length of cables connecting this product to the bridge box or transducers is large, you will have measured values substantially lower than the actual value by the amount of voltage drop of bridge source due to line resistance. The error caused by the voltage drop can be corrected by using the following table listing bridge voltage drop factors.

Bridge voltage drop factors (approximate in %):

Bridge resistance ( $\Omega$ )	Length of cable between this product and bridge box (Wire type: AWG20, at +20°C)			
	20 m	50 m	100 m	200 m
120 $\Omega$	- 1.2	- 3.0	- 5.8	- 11.0
350 $\Omega$	- 0.4	- 1.1	- 2.1	- 4.1
500 $\Omega$	- 0.3	- 0.7	- 1.5	- 2.9
1 k $\Omega$	- 0.1	- 0.4	- 0.7	- 1.5

### 1.10.2. How to set 2ch DC Strain Amp Unit (DCST, Model AP11-110)

This section covers operations in the Amp Basic screen that appears when the Amp button on the operation panel is pressed and the Amp Detailed screen that appears when the channel button is pressed.

The displayed contents are those in Strain measurement mode as shown below.

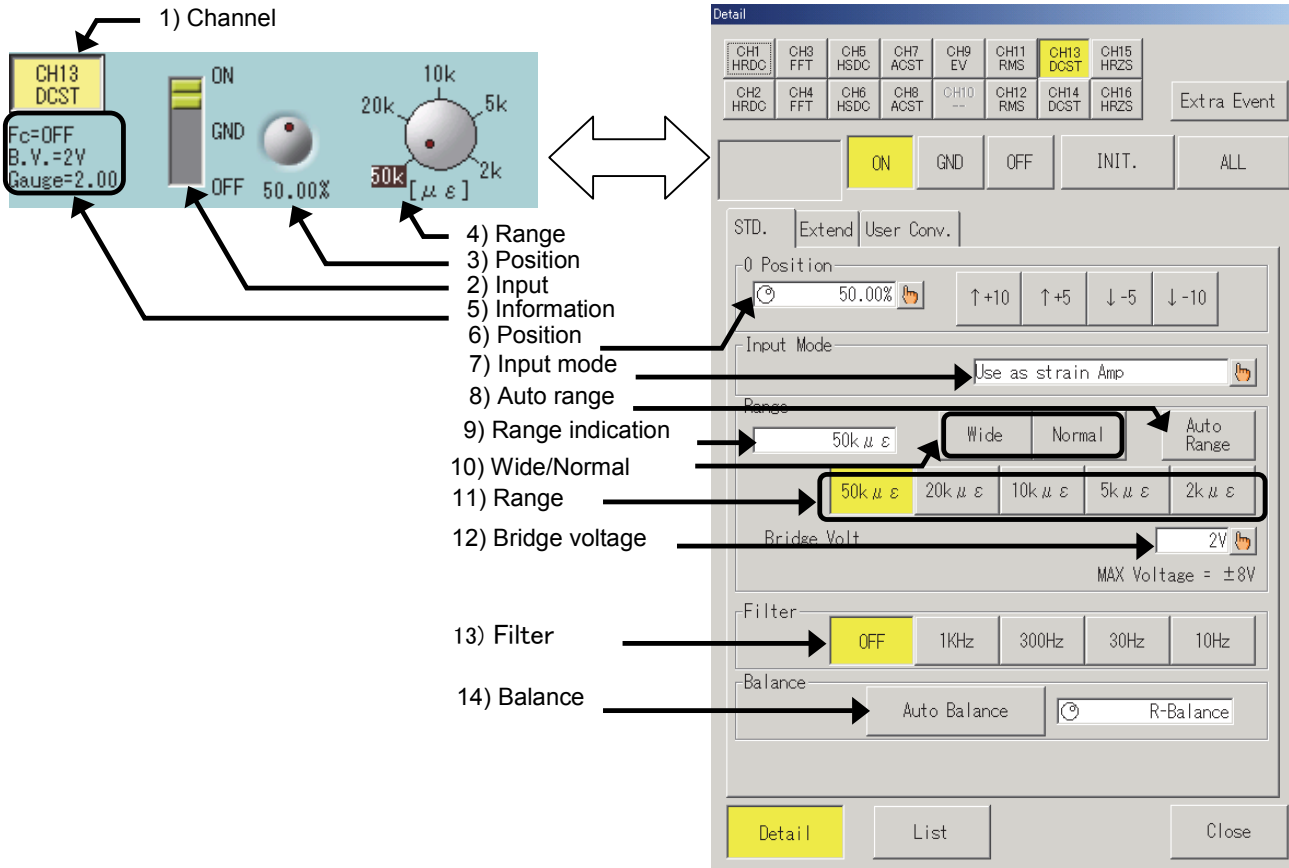

- 1) Basics - Channel  
The channel number, input amp unit type, and waveform color are indicated in this portion. Pressing this button displays the Amp Details screen.
- 2) Basics - Input  
Input mode can be selected. Pressing this button permits switching among ON, GND, and OFF.
- 3) Basics - Position  
This button is used to zero position. Pressing this button changes the button appearance. The setup can be made with the jog dial.
- 4) Basics - Range  
This button is used to set the range. Pressing this button changes the button appearance. The setup can be made with the jog dial. The displayed contents are the same as those in Voltage Measurement Mode. That is, the contents are different from those for Vibration Measurement Mode.
- 5) Basics – Information indication  
This portion indicates settings that are unable to be set on this screen. When changing the settings, make the settings in the Amp Detailed screen.  
Fc: Filter setting  
BV: Bridge Voltage setting  
Gauge: Gauge factor setting

## 6) Details - Position

The zero position (base line) is set with a button. The zero position means the waveform display position at 0V input (input short). The base line can be set in 5% steps in reference to 100% as the full scale. Also, you can set it with the jog dial by pressing the jog button, or set it from the numeric input window by pressing the window button. And the position change is available through the setup of Physical Unit Conversion or Printing/Display Range. For more information, see Chapter 4. Physical Unit Conversion – Changing Printing/Display Range.

## 7) Details – Input mode

This button is used to set the measurement mode of input signal. The change of range contents can be made to set input mode. When the voltage measurement is set, Bridge Voltage setting is invalid (No invalid indication).

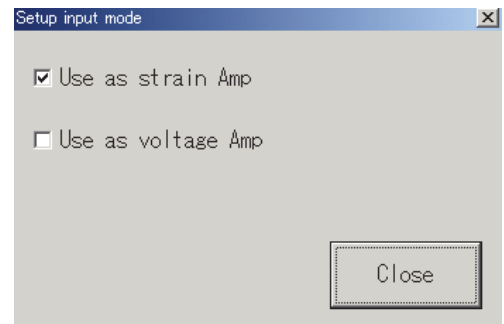

## 8) Details – Auto range

This button is automatically set the range adjustment corresponding to input signal.

## 9) Details - Range indication

The value of the current display range is displayed.

"#" is displayed when selecting the "Wide" range or changing "Printing / Display Range". After that, if you select the "Normal" range, the setting of "Printing / Display Range" is cleared and "#" disappears.

Also, when checking "Set EU." on the "User Conv." Tab and setting to use physical unit conversion, the full scale converted value will be displayed with \*.

For more information on physical unit conversion and printing / display range setting, see Chapter 4. Physical Unit Conversion - Changing Printing / Display Range.

## 10) Details – Wide/Normal

Wide: Entire measuring range is displayed.

Normal: Half of measuring range is displayed (Default).

## 11) Details - Range

The range can be directly set. Range contents change depending on the input mode settings.

**TIPS**

When the measurement range is changed, the waveform clip range is cleared to the default value corresponding to the new range.

## 12) Details – Bridge voltage

When input mode is set the Strain, bridge voltage is set. Range contents change if setting is changed.

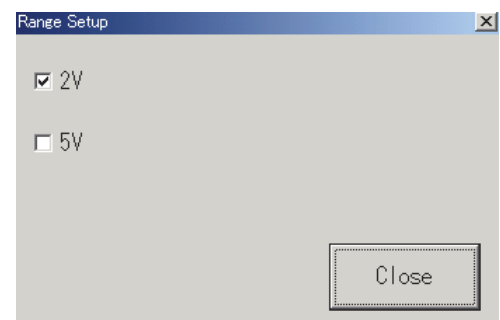

## 13) Details - Filter

Value for the low-pass filter can be set.

## 14) Details - Balance

Pressing the Auto Balance button automatically performs R balances, thereby canceling the initial imbalance (offset). If the adjustment cannot be made correctly, the R-balance can be adjusted by turning the jog dial after pressing the R-Balance button.

### 1.10.3. Gauge Factor Setup

When the input mode is strain, the gauge factor can be set based on the strain gauge being used. Setting the gauge factor outputs the measurement value with corrections. The corrections are effective on digital value indication and trigger level. Press the Gauge Factor button in the Expansion tab in the Amp Details screen to set the gauge factor with the jog dial. Alternatively, press the Window button to set the gauge factor through the value entry window.

Setup range	1.50 to 2.50
Resolution	0.01
Default	2.00

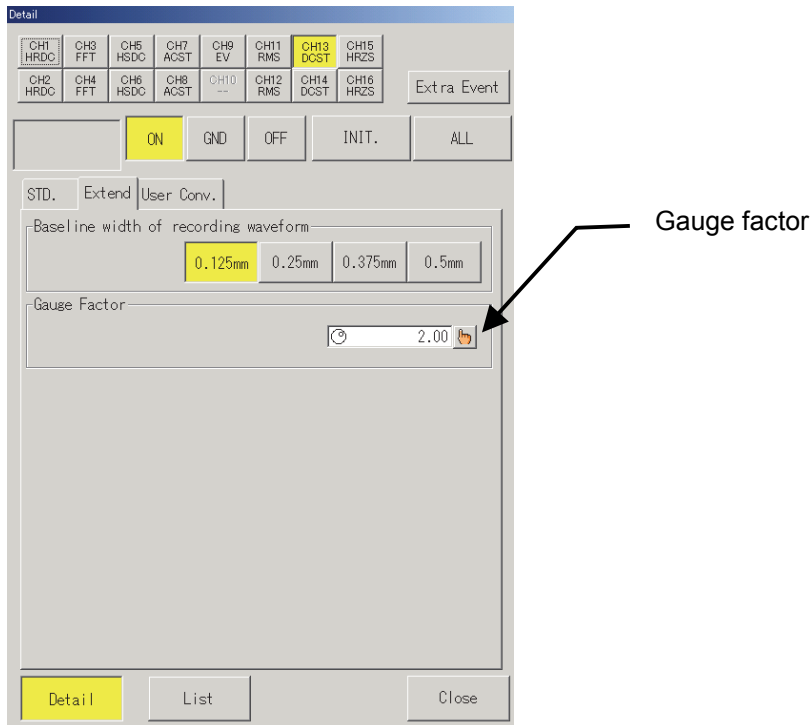



## 1.10.4. Specifications of 2ch DC Strain Amp Unit (DCST, Model AP11-110)

Number of channels	2 channels (chs)/unit	
Input mode	Unbalanced input (Each channel is insulated to each other and also from cabinet.)	
Input coupling mode	DC coupling	
Applicable strain gauge resistance	120Ω - 2kΩ (for BV=2V), 350Ω - 2kΩ (for BV=5V)	
Gauge factor (ratio)	2.00 (when factory shipped) 1.50 to 2.50 changeable	
Bridge voltages (BV)	2V or 5V	
Auto balance	Time required	within 0.5 sec./channel
	Accuracy in residual voltage	within ±0.3%-FS
Balancing range	Within ±3% (strain of 15000x10 <sup>-6</sup> )	
Sensitivity and Accuracy	For use as strain amplifier:	
	BV=2V	2k, 5k, 10k, 20k and 50k x10 <sup>-6</sup> of strain-FS
	BV=5V	800, 2k, 4k, 8k and 20k x10 <sup>-6</sup> of strain-FS
	For use as DC amplifier: 2, 5, 10, 20 and 50 mV-FS	
	Accuracy	±0.3%-FS
	Stability	±0.01%/°C
Offset accuracy	Within ±0.3%-FS for use as DC amplifier *at 23°C of environment temperature of mainframe operation	
Input impedance	No Less than 10 MΩ+10 MΩ	
Linearity	Within ±0.1%-FS	
Frequency characteristics	DC - 50 kHz (within +0.5,-3 dB )	
Low pass filter	Two-pole Bessel type: 10Hz, 30Hz, 300Hz, 1kHz and OFF Attenuation characteristics: -12 dB/oct. approximately	
Permissible input voltage	±8V(DC or AC peak value)	
Permissible common mode input voltage (CMV)	300 VAC	
Common mode rejection ratio (CMRR)	No less than 100 dB for frequencies DC - 60 Hz (50, 60Hz)	
Temperature stability characteristics	Zero point: within ±0.1%-FS/°C	
	Range: within ±0.01%-FS/°C	
A/D conversion characteristics	Resolution	16 bits
	Conversion time	10 μs max.
	Conversion method	Serial comparison method
Input connector	NDIS strain input connector	
Withstand voltage	1 kV AC for one minute between input terminal and ground, and between channels.	
S/N ratio	-42 dB or greater (when set at Wide Range)	
Mass	About 240 g	

1.10.5. External drawings of 2ch DC Strain Amp Unit (DCST, Model AP11-110)

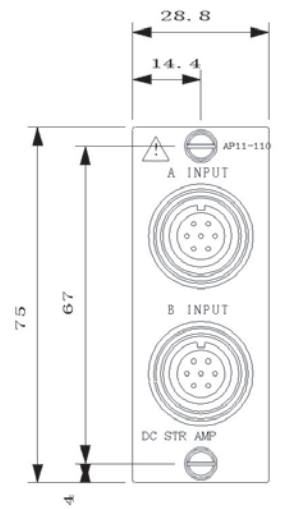
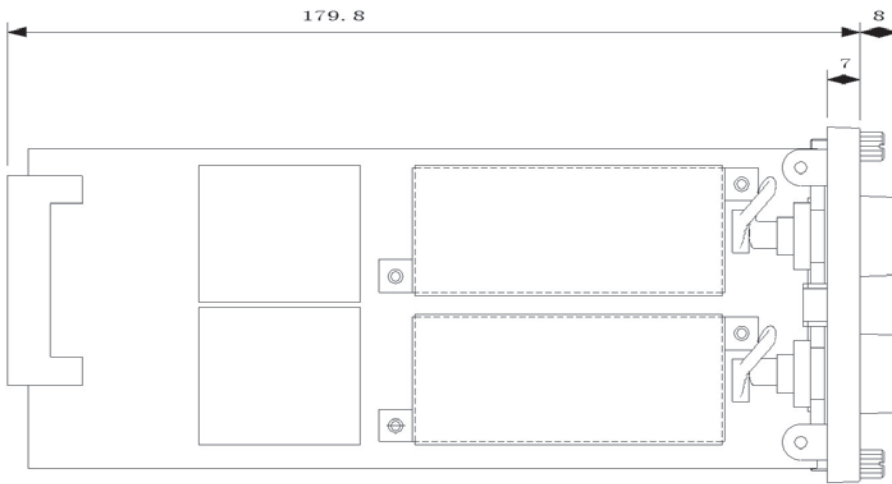
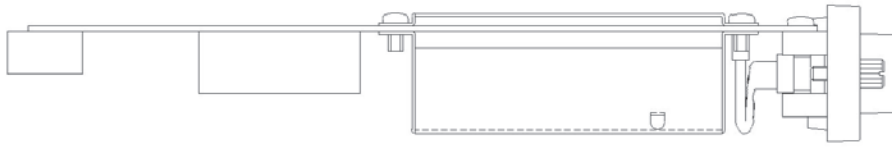

## 1.11. 2ch Zero Suppression Amp Unit (HRZS, Model AP11-111)

The 2ch Zero suppression amp unit (HRZS, Model AP11-111) is a direct-current amplifier which can increase only the varied portion of the input signal by canceling DC voltage superimposed on the input signal. In this document, this cancelled voltage is expressed as zero suppression voltage.

### 1.11.1. Connection with input signals

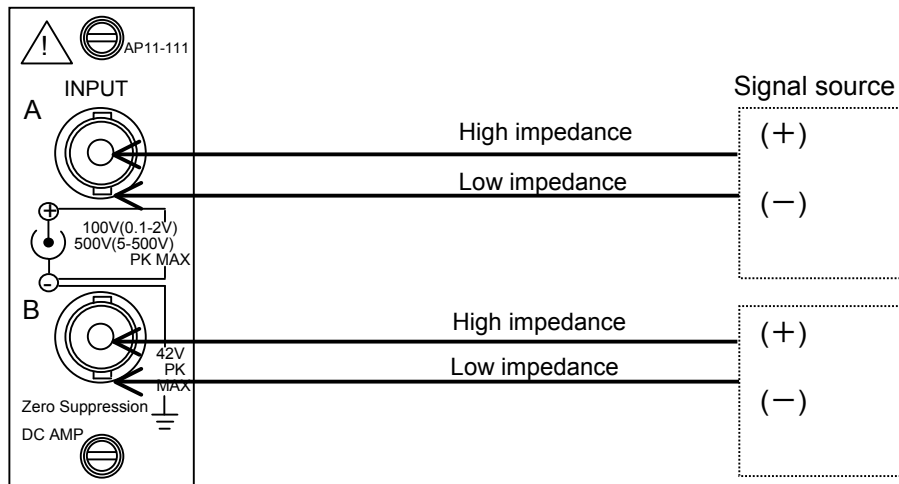

**WARNING** Always use an insulated BNC cable for signal input (Signal input cable 0311-5175, optional, 2m with BNC - Alligator clip). The polarity of the exterior metal in the metal-type BNC connector is minus. Do not touch while this cable is connected to the signal source. If you use a metal-type BNC cable, use under the condition that the permissible common mode voltage is less than  $\pm 42$  VDC (DC or AC peaks). Also, some metal type BNC cables may cause mating problems. Insulated BNC sockets may crack if they are forcibly connected, so please do not use what cannot be mated smoothly.

**NOTE** Please pay attention to the following points especially when recording small signals.  
 # Do not use an input cable that is longer than required.  
 # Use shielded cables for input connection to avoid static electricity noise.

**NOTE** Please keep the signal source resistance as low as possible (e.g. 100  $\Omega$  or less). The lower the signal source impedance is, the higher the quality of measurement record is.

### ■ Input signals

**CAUTION** Permissible input voltage  
 If a voltage higher than the rated voltage is input, this unit may be damaged due to internal damage such as component breakdown. Be sure not to exceed the following permissible input voltage for each input range.

Range (V-FS)	0.1, 0.2, 0.5, 1, 2	5, 10, 20, 50, 100, 200, 500
Permissible Input Voltage (V)	100 V	500 V

**CAUTION** Input impedance  
 The input impedance is set to approximately 1 M $\Omega$ . Note that, however, if  $\pm 15$  V or higher voltage is input in the range of 0.1 to 1 V FS at DC coupling, the input impedance is decreased to 15 M $\Omega$ .

**CAUTION** Permissible common mode input voltages (CMV)  
 Use an optional isolated BNC cable. In this case, use this cable under the condition of which common mode voltage is not exceeding  $\pm 300$  VDC or AC peak values.

## 1. How to Use Amp Unit (2ch Zero Suppression Amp Unit)

### NOTE

The sample speed must be set at 10 $\mu$ s steps, otherwise the signal waveform cannot be obtained correctly.  
Example: 5  $\mu$ s or 11  $\mu$ s, etc. makes the waveform distort.

### NOTE

Use cables with the insulation sheath of no less than 2 kV of withstand voltages.

### NOTE

Do not apply voltages exceeding the permissible common mode input voltage, since application of such voltages would lead to malfunctions or failures of equipment. Also, note that recorded waveforms may involve noise components due to degradation of common mode rejection ratio (CMRR), when noise-like impulsive common mode voltages are applied.

### NOTE

When the range is set to 0.1 to 2.0 V FS in the AC coupling, use this amp under the condition of which the input voltage within  $\pm 30$  V including the DC portion. If a signal over this voltage is input, measurement cannot be performed correctly.

### 1.11.2. How to set 2ch Zero Suppression Amp Unit (HRZS, Model AP11-111)

This section covers operations in the Amp Basic screen that appears when the Amp button on the operation panel is pressed and the Amp Details screen that appears when a channel button is pressed.

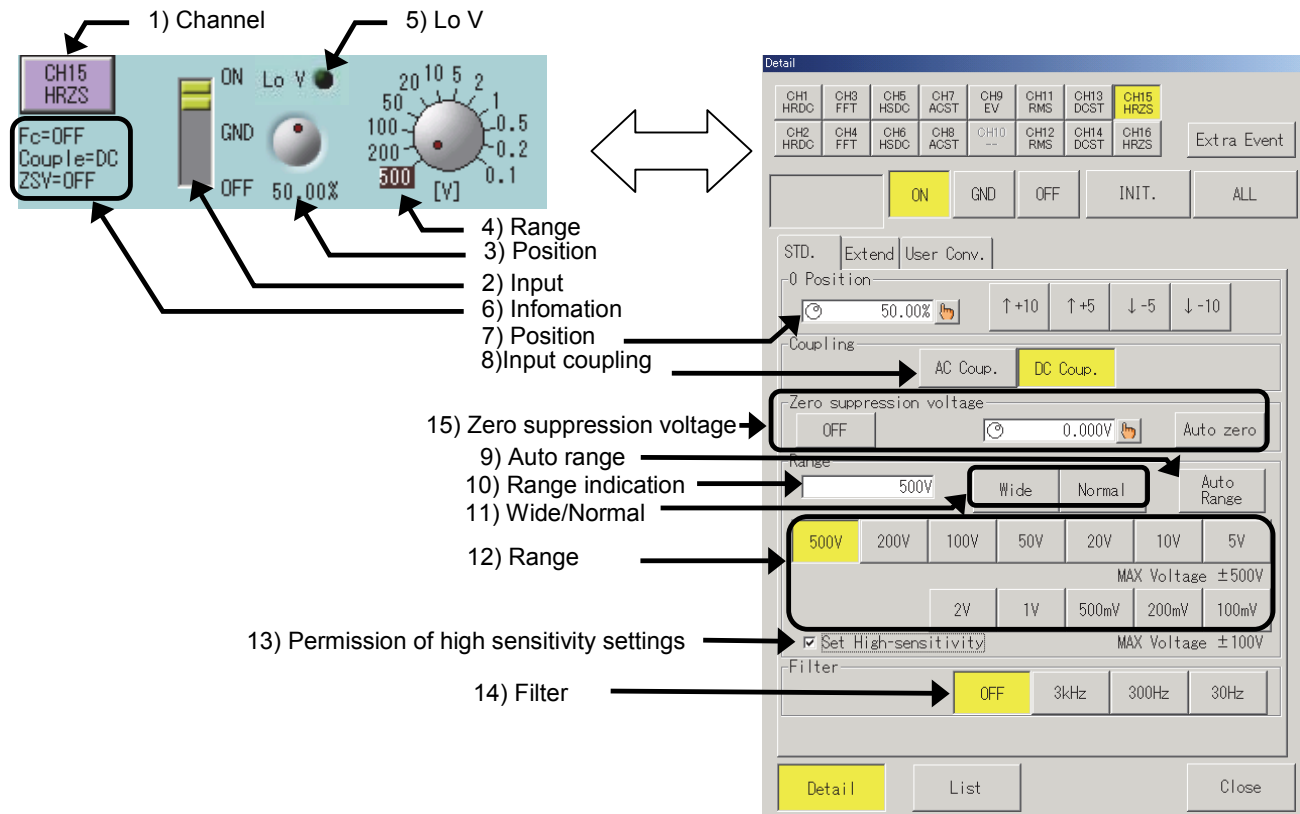

- 1) Basics - Channel  
The channel number, input amp unit type, and waveform color are indicated in this portion. Pressing this button displays the Amp Details screen.
- 2) Basics - Input  
Input mode can be selected. Pressing this button permits switching among ON, GND, and OFF.
- 3) Basics - Position  
This button is used to set the zero position. Pressing this button changes the button appearance. The setup can be made with the jog dial.

- 4) Basics - Range  
This button is used to set the range. Pressing this button changes the button appearance. The setup can be made with the jog dial.
- 5) Basics – Lo V  
The LED lights if the high sensitivity range can be permitted.
- 6) Basics - Information  
This portion indicates settings that are unable to be set on this screen. When changing the settings, make the settings in the Amp Details Screen.  
Fc: Filter setting  
Couple: Input coupling setting  
ZSV: Zero Suppression setting
- 7) Details - position  
The zero position (base line) is set with a button. The zero position means the waveform display position at 0V input (input short). The base line can be set in 5% steps in reference to 100% as the full scale. Also, you can set it with the jog dial by pressing the jog button, or set it from the numeric input window by pressing the window button. And the position change is available through the setup of Physical Unit Conversion or Printing/Display Range. For more information, see Chapter 4. Physical Unit Conversion – Changing Printing/Display Range.
- 8) Details - Input coupling  
The input coupling is set by pressing the AC coupling button or DC coupling button.

**TIPS**

When the AC coupling button is pressed, a capacitor is connected to the input terminal. The DC component can be eliminated, which enables the measurement of alternating voltage.

- 9) Details - Auto range  
The range is automatically adjusted to the input signal.
- 10) Details - Range indication  
The value of the current display range is displayed.  
"#" is displayed when selecting the "Wide" range or changing "Printing / Display Range". After that, if you select the "Normal" range, the setting of "Printing / Display Range" is cleared and "#" disappears.  
Also, when checking "Set EU." on the "User Conv." Tab and setting to use physical unit conversion, the full scale converted value will be displayed with \*.  
For more information on physical unit conversion and printing / display range setting, see Chapter 4. Physical Unit Conversion - Changing Printing / Display Range.
- 11) Details - Wide/Normal  
Wide: Entire measuring range is displayed.  
Normal: Half of the measuring range is displayed (Default).
- 12) Details - Range  
Range can be directly set.

**TIPS**

When the measurement range is changed, the waveform clip range is cleared to the default value corresponding to the new range.  
Example: During expansion of the waveform in the waveform clip range between +40 and -40 at 100 V, if the range is set to 100 V again, the waveform clip range is set to between +50 to -50 as the default. (Enlarged display is cancelled.)



Pay attention to the permissible input voltage when setting the range. See Permissible input voltages in "Input Signals".

- 13) Details - Permission of high sensitivity settings  
Settings to the high-sensitivity range (5 V to 100 mV) can be prohibited/permitted.  
When using the high-sensitivity range, check the check box.  
When the high-sensitivity range is not used, prohibition of the high-sensitivity range without checking the box is recommended for safety.
- 14) Details - Filter  
This button is used to set the low-pass filter.

## 1. How to Use Amp Unit (2ch Zero Suppression Amp Unit)

### 15) Details - Zero suppression voltage

This is used to set the DC voltage value to be cancelled for the input signal.

The following figure shows the setting portion for zero suppression voltage separated from the Amp Details screen.

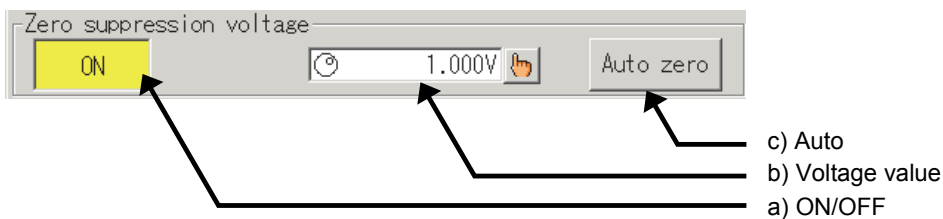

#### a) Zero suppression ON/OFF

This button is used to set whether the zero suppression voltage is applied or not.

#### TIPS

When OFF is indicated, the Zero suppression voltage value and Auto zero buttons are displayed in an invalid color and the operation is prohibited. Before changing the settings, first switch the button to ON.

#### b) Zero suppression voltage value

This is used to set the zero suppression voltage value. The setting can be made with the jog dial or through the value entry window. The setting is restricted by the input range.

The adjustable range and resolution of the zero suppression voltage to the input range are described below.

Input range	Adjustable range	Set resolution
0.1 to 2 V-FS	$\pm 13$ VDC	500 $\mu$ V
5 to 500 V-FS	$\pm 110$ VDC	5 mV

#### NOTE

In the range of 5 to 500V, the zero suppression voltage is adjustable up to  $\pm 130$ V but the precision of the range of the residual voltage is ensured only within  $\pm 110$ V.

#### TIPS

If the zero suppression voltage exceeds the specification limits by changing the range, OVER is displayed.

#### c) Auto zero suppression

The zero suppression voltage can be automatically adjusted.

### 1.11.3. Specifications of 2ch Zero Suppression Amp Unit (HRZS, Model AP11-111)

Number of channels	2 channels (chs)/unit	
Input type	Unbalanced input (insulation: between channels (ch) inside the unit, between each ch and the cabinet)	
Input coupling	AC coupling, DC coupling	
Sensitivity, Accuracy	Input range	0.1, 0.2, 0.5, 1, 2 V-FS ( $\pm 30V$ or less at AC coupling) 5, 10, 20, 50, 100, 200, 500 V-FS For all ranges (i.e., $\pm 0.1$ to $\pm 500$ V-FS), Wide-range is available.
	Accuracy	Within $\pm 0.5\%$ -FS *Within $\pm 1\%$ -FS for 500 V-FS
Offset accuracy	Within $\pm 0.5\%$ -FS * at 23°C of environment temperature of mainframe operation	
Input impedance	1 M $\Omega$ or higher	
Permissible input voltage	$\pm 500V$ (DC or AC peak value) * $\pm 100V$ (DC or AC peak value) for input ranges of 0.1 - 5 V-FS	
Permissible common mode input voltage (CMV)	$\pm 42V$ for the unit only (DC or AC peak value) *300 VAC when using an insulation BNC cable (signal cable 0311-5175)	
Common mode rejection ratio (CMRR)	80 dB or higher at up to 60 Hz	
Frequency characteristics	At DC coupling: DC to 10 kHz (within the range between +0.5 and -3 dB) At AC coupling: 0.3 Hz to 10 kHz (within the range between +0.5 and -3 dB)	
Zero suppression voltage	Setting range	0.1, 0.2, 0.5, 1, 2 V-FS ..... $\pm 13$ V 5, 10, 20, 50, 100, 200, 500 V-FS ..... $\pm 110$ V
	Setting precision	Within -0.5%~+0% within the range of $\pm 13$ V or $\pm 110$ V
	Resolution	0.1, 0.2, 0.5, 1, 2 V-FS .....500 $\mu V$ 5, 10, 20, 50, 100, 200, 500 V-FS .....5 mV
	Temp. stability	Within $\pm 0.005\%$ /°C (at a suppression voltage of 13 V)
Auto zero suppression	Process time: Within 1 sec/ch Residual voltage: Within 10-fold resolution	
Linearity	Within $\pm 0.2\%$ -FS	
Low-pass filter	2-pole vessel type: 30 Hz, 300 Hz, 3 kHz and OFF Attenuation characteristics: approx. -12 dB/oct	
Temp. stability	Zero point: Within $\pm 0.02\%$ -FS/°C Range: Within $\pm 0.01\%$ -FS/°C	
A/D conversion	Resolution	16 bits
	Conversion time	Max. 10 $\mu s$
	Conversion method	Successive comparison method
Input connector	Insulation type BNC connector	
Withstand voltage	1.5 kV AC for one minute between input connector and ground, and between channels	
S/N ratio	-46 dB or higher (at the wide range setting)	
Mass	About 250g	

1.11.4. External drawings of 2ch Zero Suppression Amp Unit

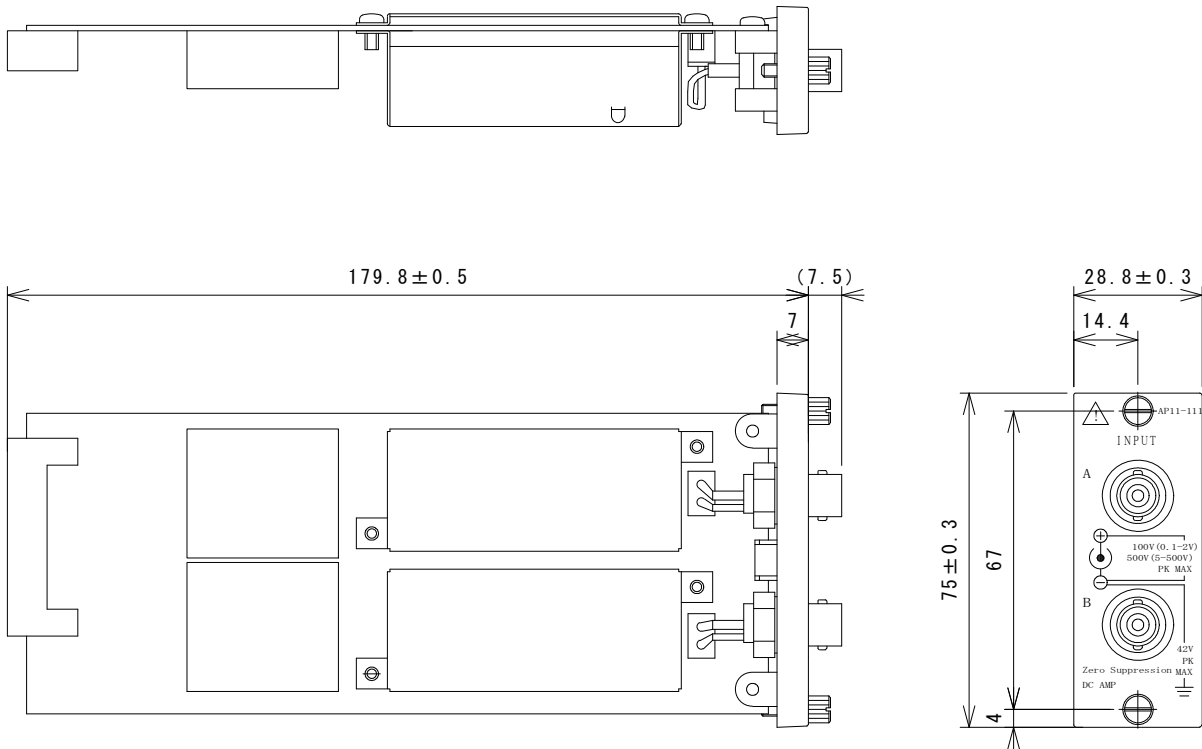



## ***2. Common Settings for Amp Details Screen***

## 2.1. ON/OFF/GND, Batch, and Initialization

The following settings are available in the Amp Details screen.

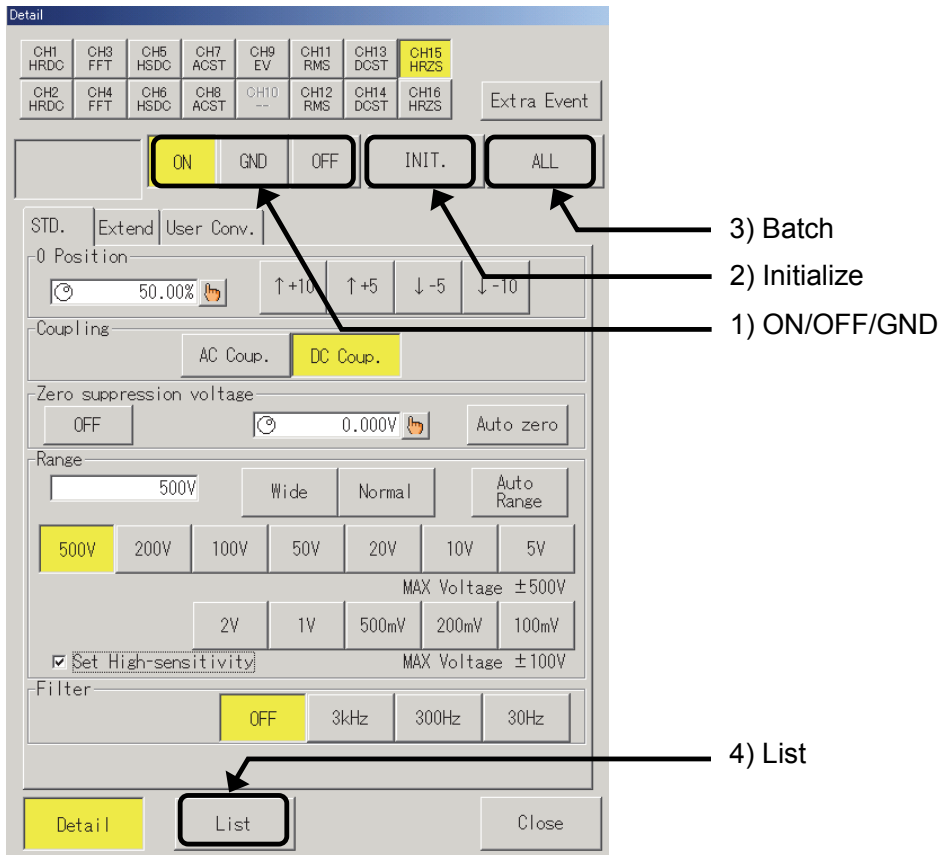

- 1) Details - ON/OFF/GND  
Display and recording for channels are set with these buttons. When the GND is selected, data for equivalent to 0 is output.
- 2) Details - Initialize  
This button initializes settings of each channel.
- 3) Details - Batch  
Settings for the same types of amps can be made at once with the Batch button. Accordingly, modifications in settings for several channels can be made. While this button is pressed, the Batch function is effective: modifications in settings in one channel are reflected to other channels. Simply pressing this button does not set anything.
- 4) Details - List  
The setup status for each channel can be observed by tab, namely Standard, Expansion, and Physical Unit Conversion.

■ Standard display screen when the List button is pressed.

Standard List

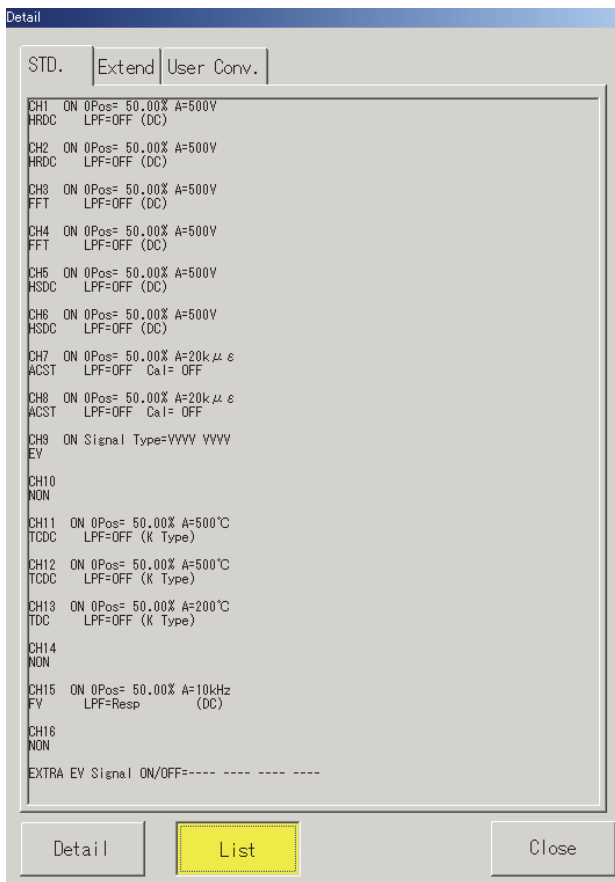

Expansion

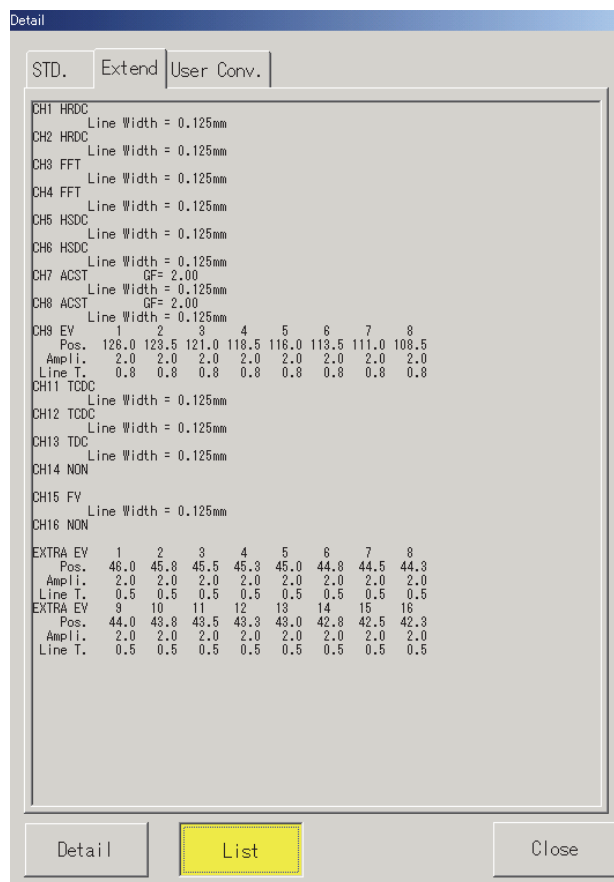

Physical Unit Conversion List

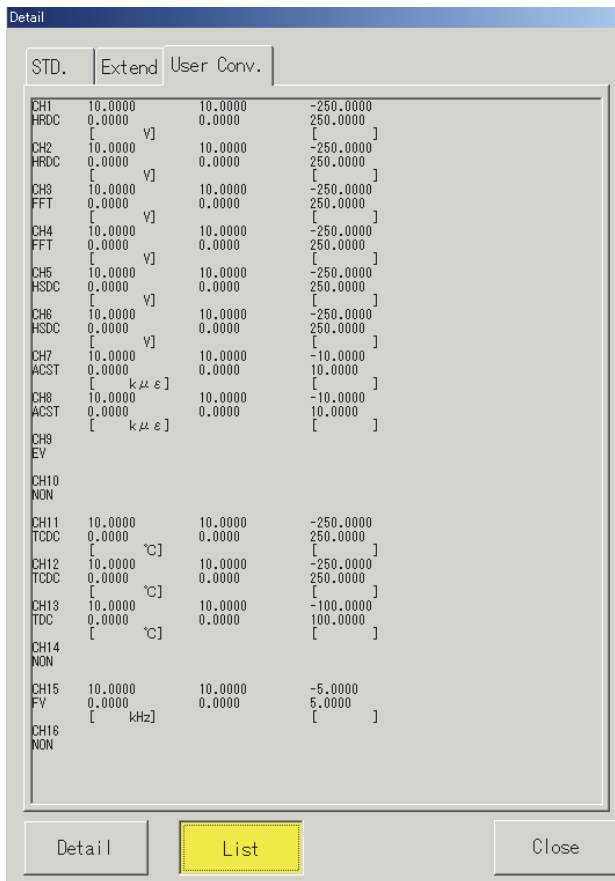

## 2.2. Initialization of Amp

### 2.2.1. Initialization in Standard Screen

2ch High-Resolution DC Amp Unit (AP11-101)

Detail

CH1 HRDC	CH3 FFT	CH5 HSDC	CH7 ACST	CH9 EV	CH11 TCDC	CH13 TDC	CH15 FV	
CH2 HRDC	CH4 FFT	CH6 HSDC	CH8 ACST	CH10 --	CH12 TCDC	CH14 --	CH16 --	Extra Event

ON GND OFF INIT. ALL

STD. | Extend | User Conv.

0 Position: 50.00%

Coupling: AC Coup. DC Coup.

Range: 500V Wide Normal Auto Range

500V 200V 100V 50V 20V 10V  
MAX Voltage ±500V

5V 2V 1V 500mV 200mV 100mV  
MAX Voltage ±100V

Set High-sensitivity

Filter: OFF 3kHz 300Hz 30Hz

Detail List Close

HRDC 2ch FFT Amp Unit (AP11-102):FFT

Detail

CH1 HRDC	CH3 FFT	CH5 HSDC	CH7 ACST	CH9 EV	CH11 TCDC	CH13 TDC	CH15 FV	
CH2 HRDC	CH4 FFT	CH6 HSDC	CH8 ACST	CH10 --	CH12 TCDC	CH14 --	CH16 --	Extra Event

ON GND OFF INIT. ALL

STD. | Extend | User Conv.

0 Position: 50.00%

Coupling: AC Coup. DC Coup.

Range: 500V Wide Normal Auto Range

500V 200V 100V 50V 20V 10V  
MAX Voltage ±500V

5V 2V 1V 500mV 200mV 100mV  
MAX Voltage ±100V

Set High-sensitivity

Filter: OFF 3kHz 300Hz 30Hz Anti\_Alias.

Detail List Close

2ch High-Speed DC Amp Unit (AP11-103):HSDC

Detail

CH1 HRDC	CH3 FFT	CH5 HSDC	CH7 ACST	CH9 EV	CH11 TCDC	CH13 TDC	CH15 FV	
CH2 HRDC	CH4 FFT	CH6 HSDC	CH8 ACST	CH10 --	CH12 TCDC	CH14 --	CH16 --	Extra Event

ON GND OFF INIT. ALL

STD. | Extend | User Conv.

0 Position: 50.00%

Coupling: AC Coup. DC Coup.

Range: 500V Wide Normal Auto Range

500V 200V 100V 50V 20V 10V  
MAX Voltage ±500V

5V 2V 1V 500mV 200mV 100mV  
MAX Voltage ±100V

Set High-sensitivity

Filter: OFF 50kHz 5kHz 500Hz 50Hz 5Hz

Detail List Close

2ch AC Strain Amp Unit (AP11-104/104A):ACST

Detail

CH1 HRDC	CH3 FFT	CH5 HSDC	CH7 ACST	CH9 EV	CH11 TCDC	CH13 TDC	CH15 FV	
CH2 HRDC	CH4 FFT	CH6 HSDC	CH8 ACST	CH10 --	CH12 TCDC	CH14 --	CH16 --	Extra Event

ON GND OFF INIT. ALL

STD. | Extend | User Conv.

0 Position: 50.00%

Range: 20 με Wide Normal

20k με 10k με 5k με 2k με 1k με

Filter: OFF 300Hz 100Hz 30Hz 10Hz

Caribration: + OFF -

5000 με 3000 με 2000 με 1000 με 500 με

Balance: Auto Balance R-Balance

Detail List Close

Event Amp Unit (AP11-105): EV

Detail

CH1 HRDC	CH3 FFT	CH5 HSDC	CH7 ACST	CH9 EV	CH11 TCDC	CH13 TDC	CH15 FV
CH2 HRDC	CH4 FFT	CH6 HSDC	CH8 ACST	CH10 --	CH12 TCDC	CH14 --	CH16 --

Extra Event

ON OFF INIT. ALL

STD. Extend

Signal Type

1	2	3	4	5	6	7	8	Volt
<input type="checkbox"/>	<input type="checkbox"/>	<input type="checkbox"/>	<input type="checkbox"/>	<input type="checkbox"/>	<input type="checkbox"/>	<input type="checkbox"/>	<input type="checkbox"/>	Contact

Event waveform print ON/OFF

1	2	3	4	5	6	7	8	ON
<input type="checkbox"/>	<input type="checkbox"/>	<input type="checkbox"/>	<input type="checkbox"/>	<input type="checkbox"/>	<input type="checkbox"/>	<input type="checkbox"/>	<input type="checkbox"/>	OFF

Detail List Close

2ch TC·DC Amp Unit (AP11-106/106A): TCDC

Detail

CH1 HRDC	CH3 FFT	CH5 HSDC	CH7 ACST	CH9 EV	CH11 TCDC	CH13 TDC	CH15 FV
CH2 HRDC	CH4 FFT	CH6 HSDC	CH8 ACST	CH10 --	CH12 TCDC	CH14 --	CH16 --

Extra Event

ON GND OFF INIT. ALL

STD. Extend User Conv.

0 Position

50.00%

Input Mode

Measure with °C

Range

500°C

R Type T Type J Type W Type

1800°C 400°C 1200°C 2400°C

K Type

1400°C 500°C

Filter

OFF 5kHz 500Hz 30Hz 1Hz

User internal R.J.C

Detail List Close

TC·DC Amp Unit (AP11-107): TDC

Detail

CH1 HRDC	CH3 FFT	CH5 HSDC	CH7 ACST	CH9 EV	CH11 TCDC	CH13 TDC	CH15 FV
CH2 HRDC	CH4 FFT	CH6 HSDC	CH8 ACST	CH10 --	CH12 TCDC	CH14 --	CH16 --

Extra Event

ON GND OFF INIT. ALL

STD. Extend User Conv.

0 Position

50.00%

Input Mode

Measure with °C

Range

200°C

R Type T Type

1600°C 800°C 400°C 200°C

J Type K Type

1000°C 200°C 1200°C 200°C

Filter

OFF 5kHz 500Hz 30Hz 1Hz

User internal R.J.C

Detail List Close

F/V Converter Unit (AP11-108): FV

Detail

CH1 HRDC	CH3 FFT	CH5 HSDC	CH7 ACST	CH9 EV	CH11 TCDC	CH13 TDC	CH15 FV
CH2 HRDC	CH4 FFT	CH6 HSDC	CH8 ACST	CH10 --	CH12 TCDC	CH14 --	CH16 --

Extra Event

ON OFF INIT. ALL

STD. Extend User Conv.

0 Position

50.00%

Coupling

AC Coup. DC Coup.

Range

10kHz

10kHz 5kHz 2kHz 1kHz

500Hz 200Hz 100Hz

Trigger Level

0V 2.5V

Filter

Ripple first Resp. first

Detail List Close

## 2. Common Settings in Amp Details Screen

### 2ch Vibration RMS Amp Unit (AP11-109): RMS

Detail

CH1 HRDC	CH3 FFT	CH5 HSDC	CH7 ACST	CH9 EV	<b>CH11 RMS</b>	CH13 DCST	CH15 HRZS	Extra Event
CH2 HRDC	CH4 FFT	CH6 HSDC	CH8 ACST	CH10 --	CH12 RMS	CH14 DCST	CH16 HRZS	

ON  GND  OFF  INIT.  ALL

STD. | Extend | User Conv.

RMS converter mode  
 0 Position:

Coupling:  AC Coup.  **DC Coup.**

Range:  Wide Normal Auto Range  
 **350Vrms**  200Vrms  100Vrms  50Vrms  20Vrms  10Vrms  
 MAX Voltage ±500V  
 5Vrms  2Vrms  1Vrms  500mVrms  200mVrms  100mVrms  
 Set High-sensitivity MAX Voltage ±100V

Filter:  
 LOW PASS:  OFF  1kHz  300Hz  100Hz  30Hz  
 HIGH PASS:  OFF  1kHz  30Hz  100Hz

### 2ch DC Strain Amp Unit (AP11-110): DCST

Detail

CH1 HRDC	CH3 FFT	CH5 HSDC	CH7 ACST	CH9 EV	CH11 RMS	<b>CH13 DCST</b>	CH15 HRZS	Extra Event
CH2 HRDC	CH4 FFT	CH6 HSDC	CH8 ACST	CH10 --	CH12 RMS	CH14 DCST	CH16 HRZS	

ON  GND  OFF  INIT.  ALL

STD. | Extend | User Conv.

0 Position:

Input Mode:

Range:  Wide Normal Auto Range  
 **50k με**  20k με  10k με  5k με  2k με  
 Bridge Volt:  MAX Voltage = ±8V

Filter:  OFF  1kHz  300Hz  30Hz  10Hz

Balance:  Auto Balance  R-Balance

### 2ch Zero Suppression Amp Unit (AP11-111): HRZS

Detail

CH1 HRDC	CH3 FFT	CH5 HSDC	CH7 ACST	CH9 EV	CH11 RMS	CH13 DCST	<b>CH15 HRZS</b>	Extra Event
CH2 HRDC	CH4 FFT	CH6 HSDC	CH8 ACST	CH10 --	CH12 RMS	CH14 DCST	CH16 HRZS	

ON  GND  OFF  INIT.  ALL

STD. | Extend | User Conv.

0 Position:

Coupling:  AC Coup.  **DC Coup.**

Zero suppression voltage:  OFF

Range:  Wide Normal Auto Range  
 **500V**  200V  100V  50V  20V  10V  5V  
 MAX Voltage ±500V  
 2V  1V  500mV  200mV  100mV  
 Set High-sensitivity MAX Voltage ±100V

Filter:  OFF  3kHz  300Hz  30Hz

### 2.2.2. Amp Details – Initialization in Physical Unit Conversion Screen

Example: 2ch High-Resolution DC Amp Unit (AP11-101): HRDC

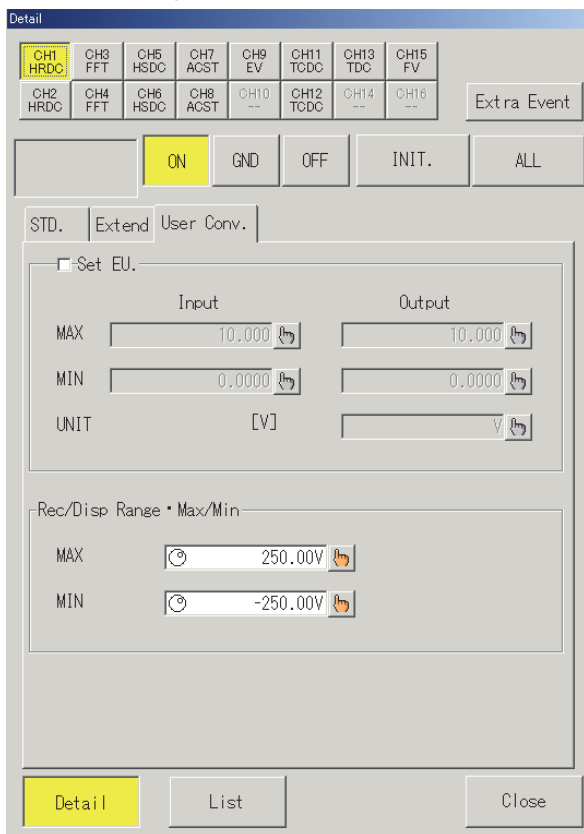

### 2.2.3. Amp Details – Initialization in Expansion Screen

(Example)

2ch High-Resolution DC Amp Unit (AP11-101):

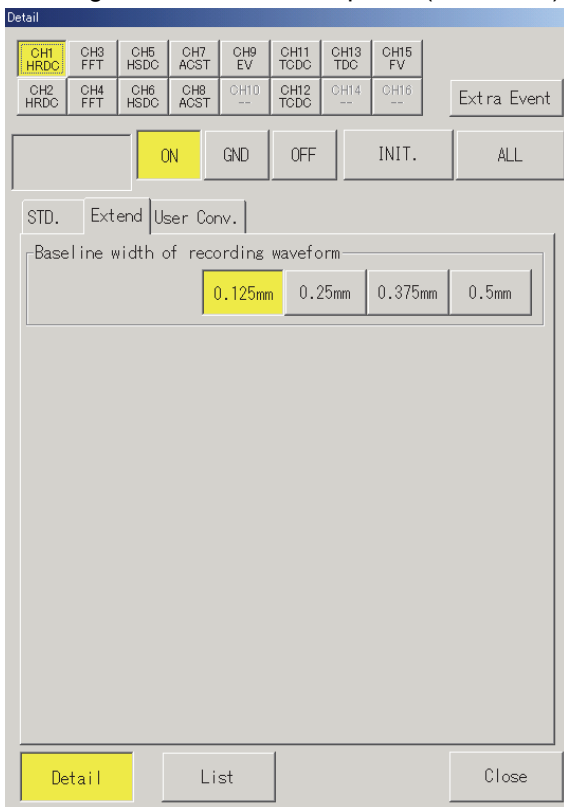

Event Amp Unit (AP11-105): EV

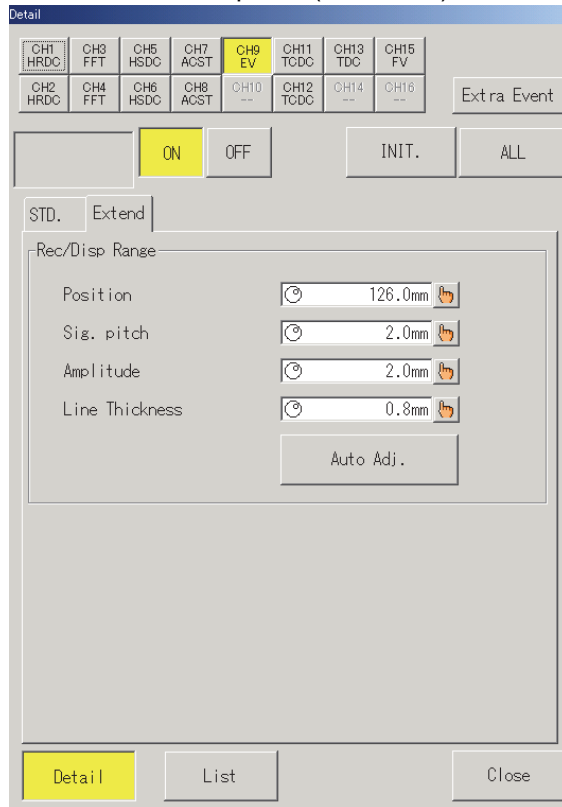





### **3. *Expansion Settings***

### 3.1. Change of Base Line Width of Printing Waveform

The following settings are available in the Amp Details screen.

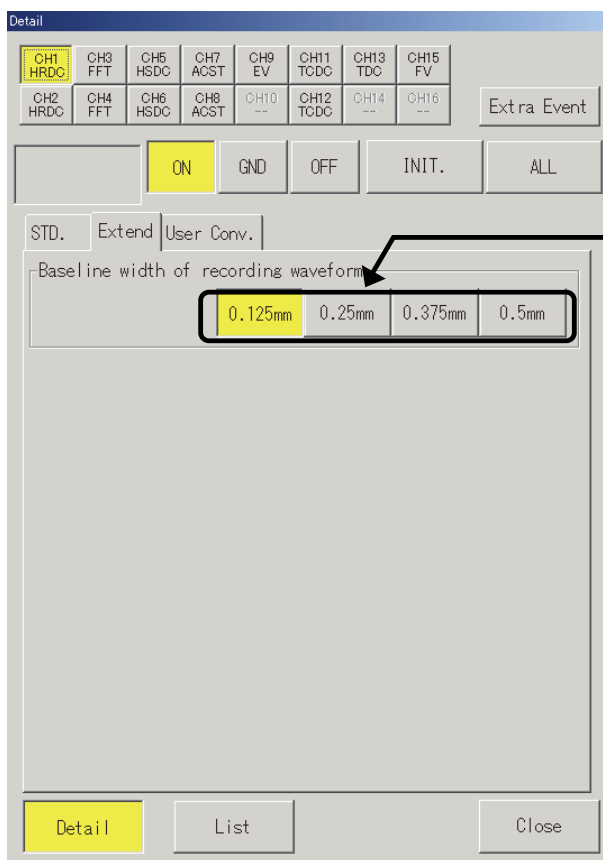

(1) Base Line Width of Printing Waveform

(1) Details – Base Line Width of Printing Waveform

The line width for printing waveform can be set for each channel.

***4. Physical Unit  
Conversion — Changing  
Printing / Display Range***

## 4.1. Overview of Physical Unit Conversion

This section explains operation of Physical Unit Conversion in User Conversion tab in the Amp Details screen. The Physical Unit Conversion is commonly provided in each analog amp, which converts the measured values into physical values and changes the printing and Display scale for waveform amplitude.

### ■ Converting physical units

Scale representation is automatically changed into the desired unit. Any complicated calculation is not needed.

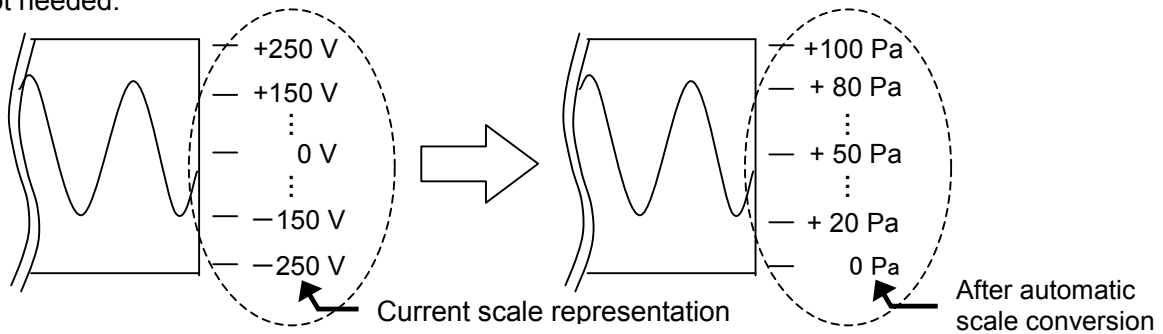

### ■ Changes printing and display range

Because the waveform amplitude can be changed, expanded display for necessary portion only is possible.

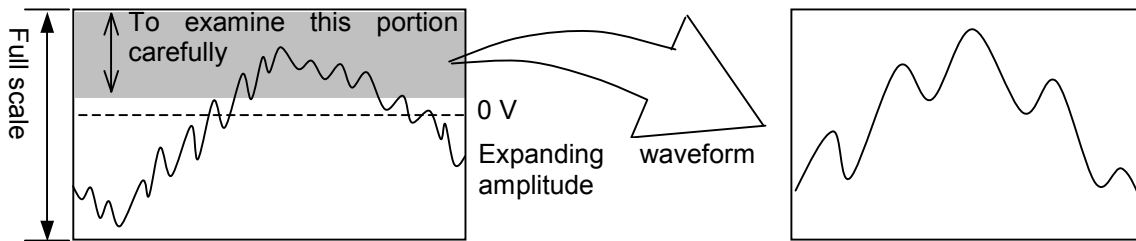

The following screen appears when the User Conversion tab in the Amp Details screen is pressed.

The screenshot shows the 'Detail' screen for the User Conversion tab. It features a grid of channel selection buttons (CH1-CH16) and control buttons (ON, GND, OFF, INIT., ALL). Below this, there are two main input/output configuration sections:

- Input/Output Section:** Contains fields for 'MAX' (10.000), 'MIN' (0.0000), and 'UNIT' ([V]). An arrow points to this section with the label 'Executing physical unit conversion'.
- Rec/Disp Range • Max/Min Section:** Contains fields for 'MAX' (250.00V) and 'MIN' (-250.00V). An arrow points to this section with the label 'Changing printing and display range in waveform representation'.

At the bottom of the screen are buttons for 'Detail', 'List', and 'Close'.

## 4.2. How to convert Physical Units

Input signals can be output after being converted into measured values. The conversion is made in the User Conversion tab in the Amp Details screen.

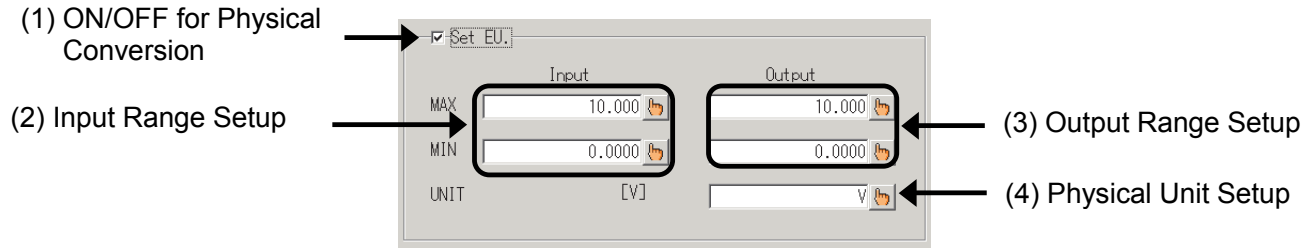

### (1) Using physical unit conversion

Specify whether to convert the scale units or not. Add a check mark when using physical unit conversion. After adding a check mark, settings of (2), (3) and (4) can be made. The \*mark that signifies that the physical unit conversion is effective is indicated at Range value indication portion.

### (2) Input range setup

The maximum and minimum values are set, which will be the references for the measurement range.

### (3) Output range setup

The maximum and minimum values are set to fix the output range against the input range. These values will be the references for the physical unit conversion.

### (4) Physical unit conversion setup

Physical unit conversion can be set. The following screen appears after the button is pressed.

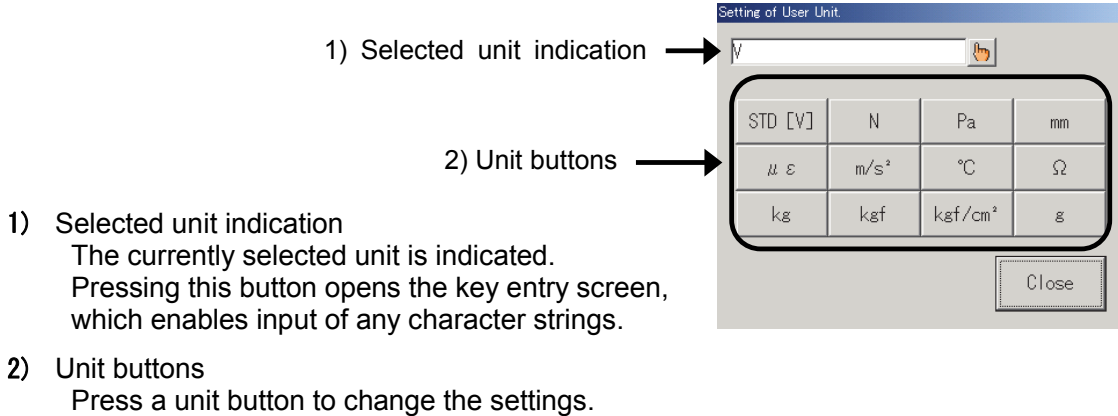

- 1) Selected unit indication  
The currently selected unit is indicated.  
Pressing this button opens the key entry screen, which enables input of any character strings.

- 2) Unit buttons  
Press a unit button to change the settings.

**TIPS**

The unit of value to be input should be the basic unit including neither kilo nor mega. Due to such entry system, physical unit conversion can be effective even amp range is changed.

**TIPS**

When value entry for physical unit conversion is made, the following functions will be effective for easy operation.

# When the input values are changed, the same values are set to the output values and printing/display range.

# When the output values are changed, the same values are set for printing/display range.

**NOTE**

In the case where the following setup is made for input maximum and minimum value settings, the measurement values will not be displayed correctly. (Even input signal changes, only certain values are output.)

# If the maximum value and minimum value are equivalent. (Division by 0 in the internal calculation will occur.)

# If the range of input maximum and minimum values does not include the effective measurement range (the measurement values exceeds the set range.).

### 4.3. Printing/Display Range

Within the currently set full-scale, maximum and minimum values of a necessary portion can be set for the full-scale.

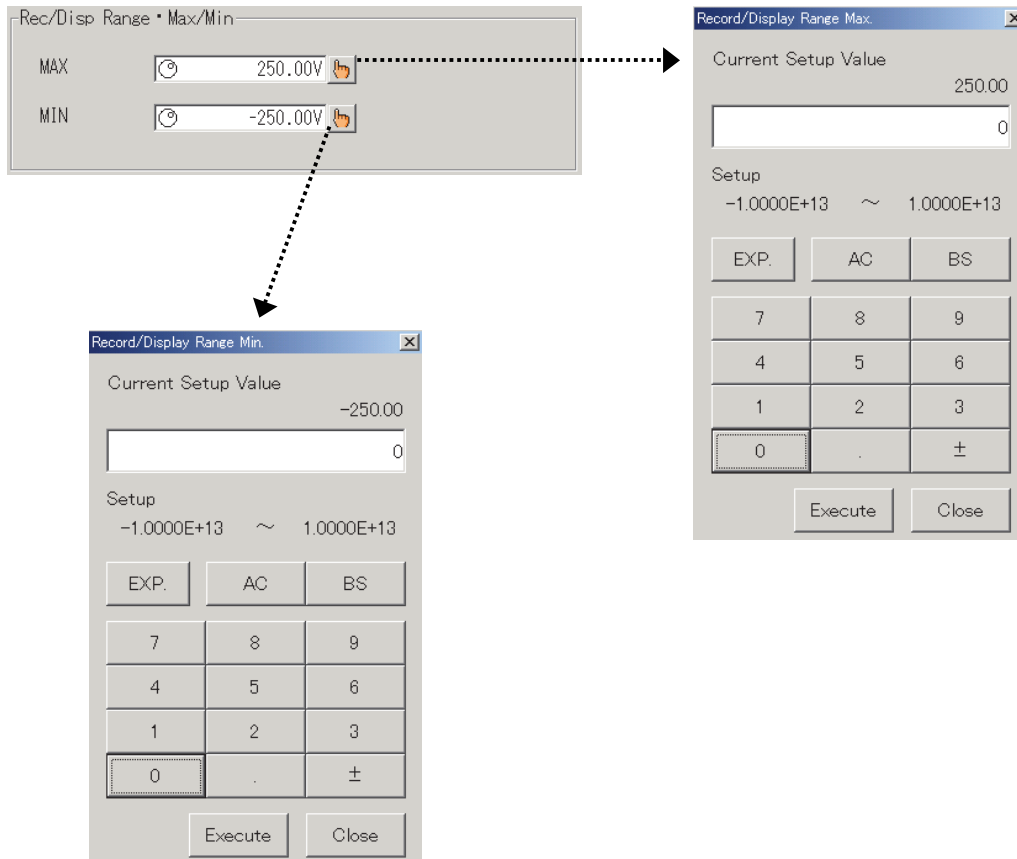
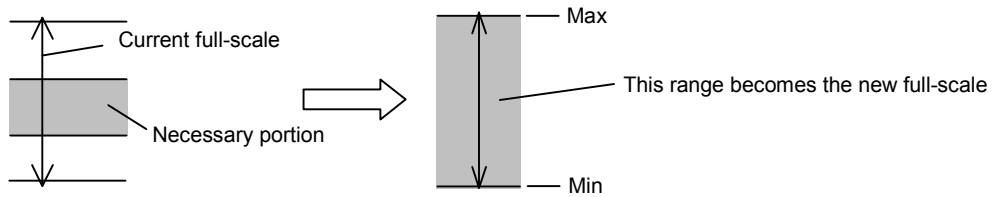

**TIPS**

Waveform can be oppositely displayed by setting to Max<Min.

Example: Max = -2.50000, Min = +2.5000

With this manner, waveform output will be up-side-down. In this case, scale representation will be up-side-down, too (Top: -2.5000, Bottom: +2.5000). To invert positive/negative for input signal, set either settings of input or outputs to Max<Min.

By setting the minimum value to 0 and setting the maximum value by the jog dial, it is possible to continuously enlarge / reduce the waveform.

Please change the center position by Position after setting the enlargement ratio.

## ***5. Procedure for Changing Amplifier Units***

Amplifier units can be changed easily, since they have plug-in mounting structure.

**However, mount or dismount amplifier units, only after you have turned off the power supply switch and disconnected the power supply cable from the mainframe.**

Mounting or dismounting amplifier units while the mainframe is powered on would lead to damages to the mainframe.

Be sure to change amplifier units after confirming the mainframe power supply switched-off by all means.

## 5.1. Example of Replacement

The following describes the procedure of changing amplifier units by taking a sample of the amplifier unit at the second position from the right as seen from the mainframe front.

- (1) Turn off the power supply switch.
- (2) Disconnect the power supply cable from the mainframe.
- (3) Disconnect all input cables that are connected to individual amplifier units.
- (4) Turn the two screws until they come off the mainframe.



Confirm that the power supply of the mainframe is off.

By using a flat tip screw driver, turn the two (2) screws at the top and bottom positions of the amplifier unit which are fixing the unit to the mainframe. (The flat tip screw driver should have the tip thickness of no more than 0.65 mm.)

Turn the screws until they come off the mainframe. (Be careful that screws might come off the amplifier unit if you turn them too much.)

- (5) Pull the amplifier unit out of the mainframe.



Hold between your fingers the two screws (at the top and bottom for RA2300A, and at the right and left sides for RA2800A) which fix the amplifier unit, and draw the unit of the mainframe toward yourself.

Thus, you can easily take the amplifier unit off the mainframe.

The mounting procedure for the amplifier unit is just the reverse of the above.

Tighten the screws firmly using a flat tip screw driver.

Operations of mounting amplifier units should also be done after switching off the mainframe power supply.



**WARNING**

Always keep blank panels mounted at individual vacant slots for input amplifier units to prevent electric shock and potential damages of the mainframe due to foreign matter penetration.



# To be used for a long time

A&D Company,Limited.

Thank you for purchasing our products.

In order to use the purchased product for a long time, we offer the following maintenance service system.

## **1. Warranty period**

One year is warranted from the date of purchase and will be repaired free of charge in the event of failure. (However, it is limited to the case where the fault that occurred is our responsibility.)

## **2. Maintenance service when the warranty period has passed**

If the warranty period has passed, the repair service will be charged.  
In addition, overhaul is also accepted at customer's request.

## **3. Maintenance agreement recommendation**

At our company we also conduct periodic inspection and maintenance services so that the products you purchase can always be used with confidence.

**Address inquiries to:**

- (1) This manual may not be reproduced to any form in whole or in part.
- (2) Then contents in this manual may be updated without prior notice.

**The AP Amplifier series units for RA2000 Series  
Instruction Manual (1WMPD4003505)**

1st Edition :        September 2017

**A&D Company, Limited**





**A&D Company, Limited**

3-23-14 Higashi-Ikebukuro, Toshima-ku, Tokyo 170-0013, JAPAN

Telephone: [81] (3) 5391-6132 Fax: [81] (3) 5391-6148