

PROTEX
SERIES

X-RAY INSPECTION SYSTEM AD-4991



INSPECTION SIMPLIFIED

AND
A&D Company, Ltd.

Discover Precision
www.aandd.jp

Why A&D Inspection

Why X-ray?

A proper HACCP program will help prevent contamination as long as the technology and processes are suitable for the application. At A&D we are committed to providing a consultative approach to help our customers enjoy full benefit from the technologies that we have worked diligently to produce. Our systems protect brand image and allow companies to expand their future business because of our reliability, ease of operation, and serviceability.

Cutting Edge Inspection

A&D Inspection offers cutting edge X-ray inspection systems to assist food packaging and pharmaceutical companies better understand how to leverage this incredible technology in an effort to improve and manage the quality of their products.

Top Considerations

X-ray systems use in food packaging and pharmaceutical applications are growing exponentially because of the versatility they provide. The increased dynamic inspection capabilities provide great confidence and increased quality control standards, which allow customers to further differentiate their brand.

X-ray Benefits Include

- Increased consumer protection
- Quality assurance - taken to new levels
- Brand protection and recall prevention
- Food safety compliance
- Customer trust
- High return on investment

Applications Include

- Ready Meals
- Prepared foods
- Meat
- Bakery Products
- Cereals
- Dairy foods
- Confectionery
- Vegetables
- Fruit
- Cosmetics

***but are not limited to**



Most Compact System on the Market

- The size of 575mm width and 800mm length makes integration painless whether it be an existing line or new production line.



15" Color Touchscreen for Easy Operation

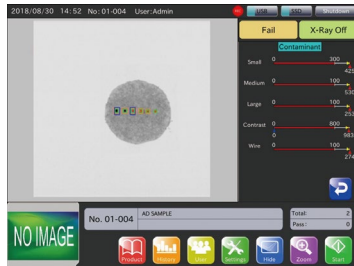

- Simple GUI for Operators of all types.
- Easy to discern good products from bad products.



Easy Product Setup

- Setting up a new product requires three passes through the machine.
- Inspection thresholds will automatically be configured based on the sample that was registered, making product setup foolproof.



1000 Unique products

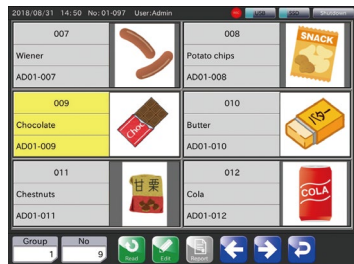

- Store products in 10 groups of 100.
- Product selector window allows the user to see all registered products at a glance.



Data Management and HACCP Compliance

- Export production reports, statistics, and image via USB or access on the machine in real-time.

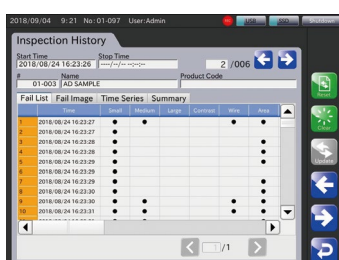

Rejects Log

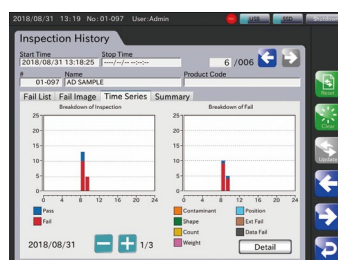

Production Charts

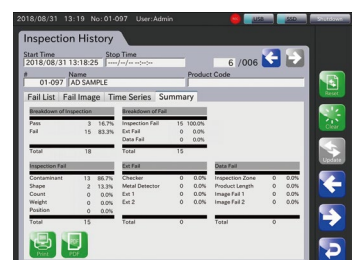

Inspection Summary

FEATURES

Foreign Matter Detection

Precise detection of the smallest of foreign contaminants.

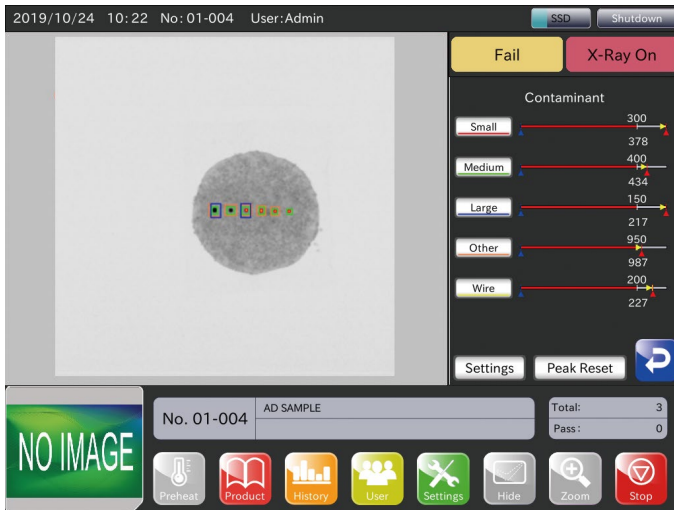

Types of contaminants X-ray can detect.

- Metal
- Non-ferrous metals in foil, including stainless steel
- Glass
- Bone (calcified)
- PVC plastic
- TFE (Teflon) plastic
- Ceramic or concrete
- Flavor/sugar clumps

Shape Detection

Check for product uniformity and flaws, such as cracks or chips.



Example of good products

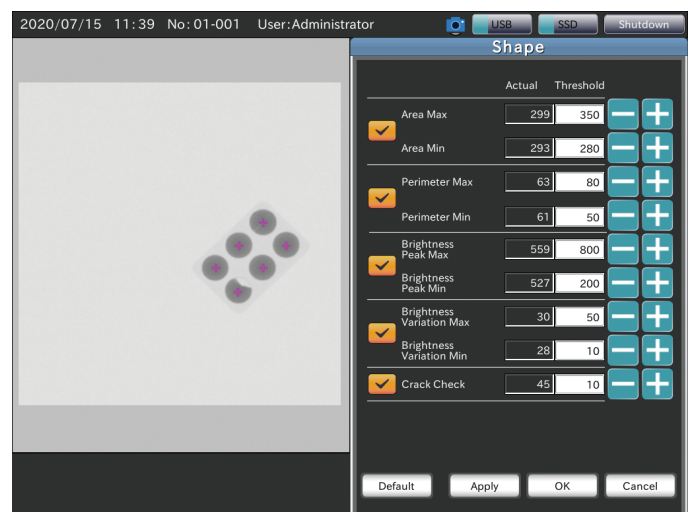

Example of a cracked product

Mass Estimation

Estimate the weight of a product to determine if it meets desired weight parameters.

The X-ray machine measures the product density to determine the approximate mass of a product. This is especially useful with continuous packaging.

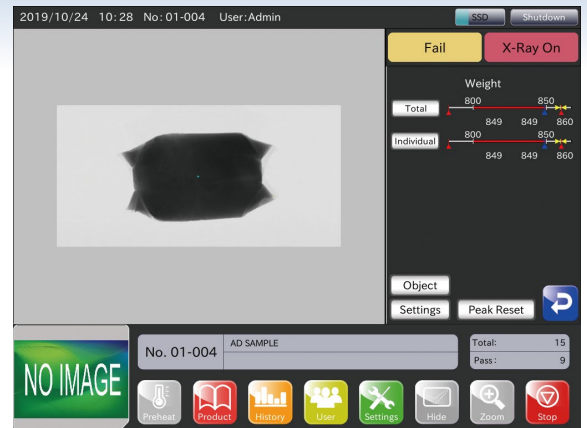

Piece Counting and Positioning

Search for missing items within a package and verify proper positioning.

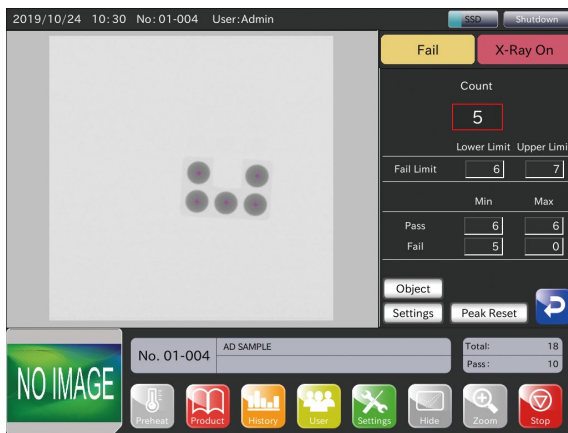

Example of a missing piece

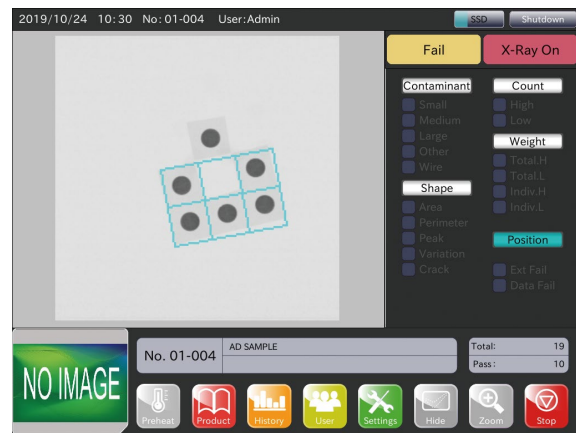

Example of misplaced product

Masking Function

Confirm product integrity and reduce the number of false rejections.

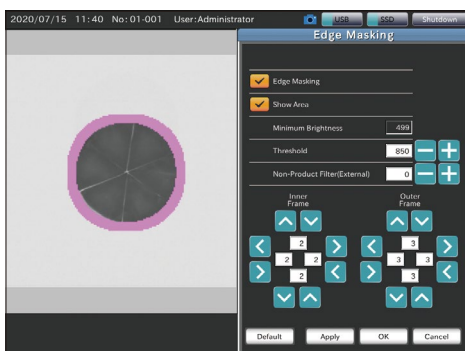

Example of masking the edge of product.

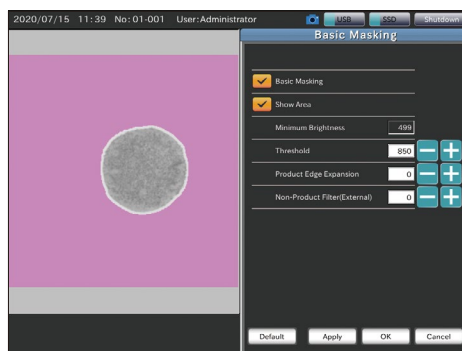

Example of masking non-inspection area.

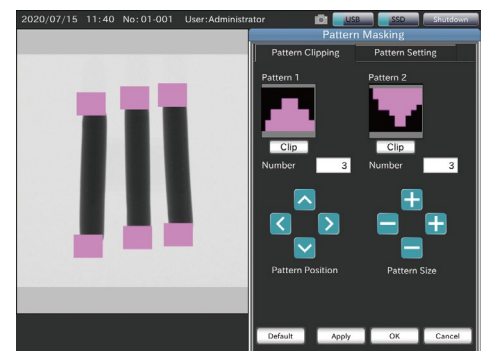

Example of masking the clipped area.

A&D X-ray systems feature advanced inspection algorithms to tackle the toughest of applications.

Basic X-ray Principles

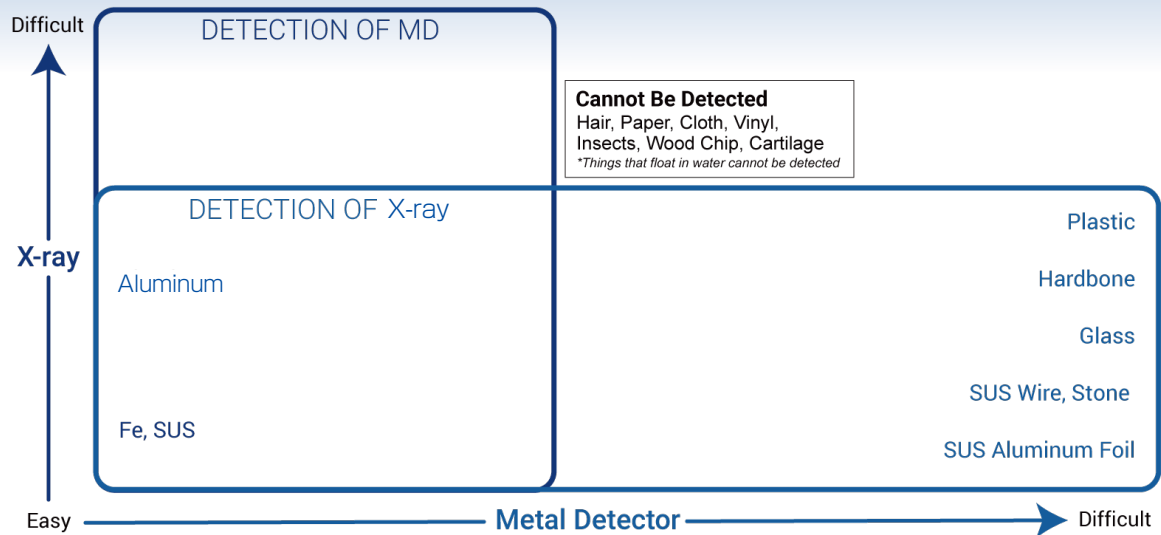

Sanitary Design

Sloped surfaces are designed to minimize water collection and maximize cleanability.



Quick release belt designed for easy cleaning and replacement.



Quick release curtains allows for easy cleaning and replacement.

X-ray Safety



Safety sensors are embedded at access points to provide additional safety.



Machine Faults are visually displayed allowing operators to quickly fix and resume operation.

Model and their dimensions

AD-4991-2510 / AD-4991-2515

AD-4991-2510

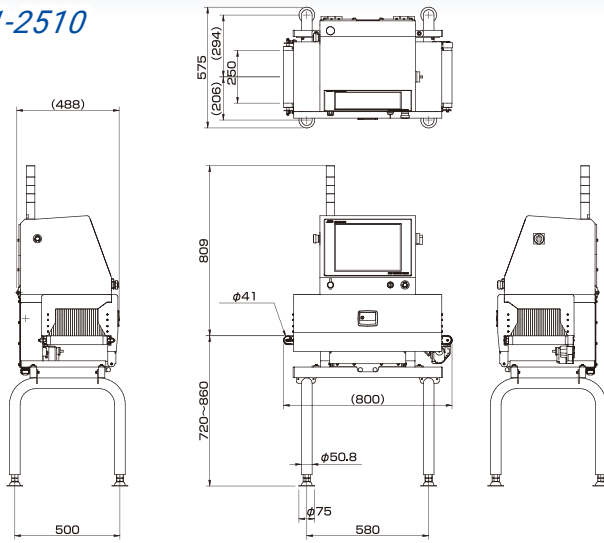

AD-4991-2515

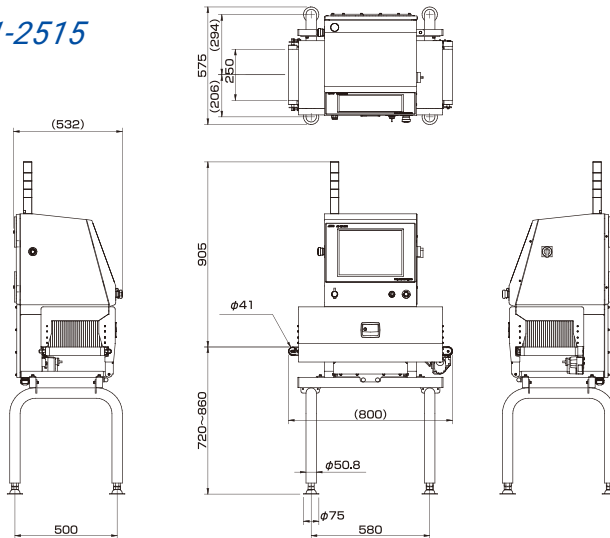

AD-4991-3530

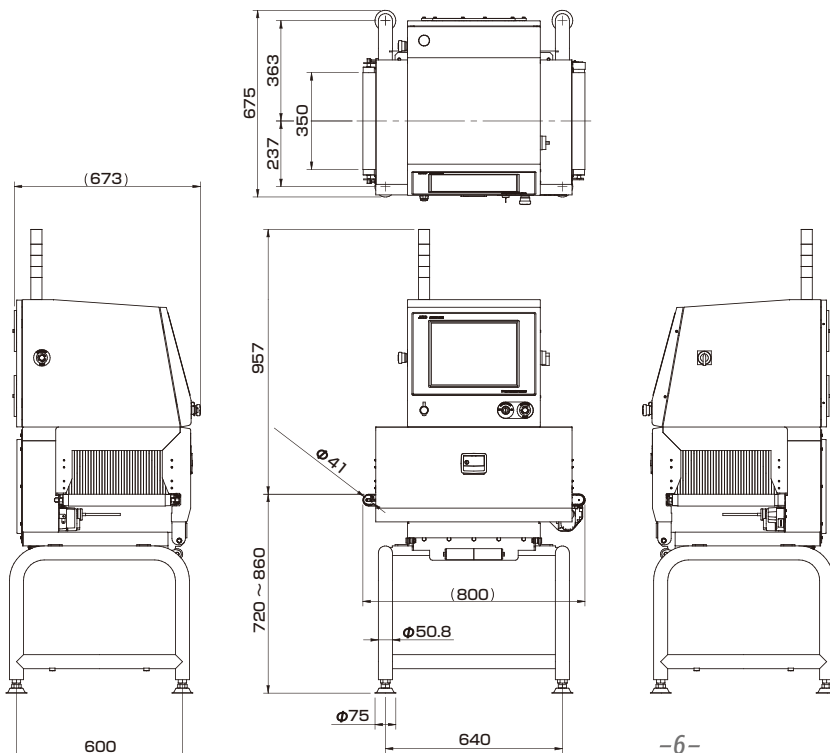

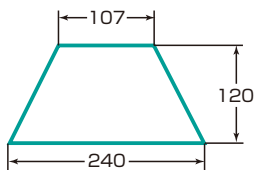
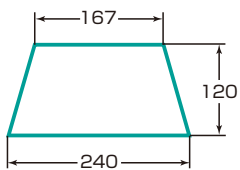
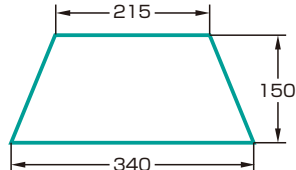
Model	AD-4991-2510	AD-4991-2515	AD-4991-3530
Conveyor width	250mm		350mm
System length	800mm		
Conveyor height	720-860mm		
X-ray output	100W(50kV_2mA)	150W(50kV_3mA)	300W (75kV_4mA)
Conveyor speed	10 to 45m/min	10 to 70m/min	10 to 45m/min
Maximum conveying capacity	5kg (depends on speed for AD-4991-2515)		
Operation temperature/humidity	0 to 35°C / humidity below 85% (with no condensation)		
Dust/water resistance specifications	IP66 for inspection room		
Power supply	Single phase AC100 to 240V(± 10%), 50/60Hz, D class grounding *1		
The maximum power consumption	About 570VA *2	About 670VA *2	About 900VA *2
Weight	About 90kg	About 105kg	About 165kg
Display	15 inch touch panel color display		
Casing material	SUS304		
Belt	Antifungal/antibacterial Polyurethane compounds		
Shielding curtain	Tungsten		
X-ray safety	Leakage less than 1 μSv/h		
Communication functions	Modbus TCP / Modbus RTU / RS232C/485 (selectable) / TCP/IP /USB (for PostScript printer, USB memory, data storage, image import use)		
External input	Non - voltage contact input 8 points *3		
External output	Relay output 8 points *3		
Number of recorded items	1000items(10groups x 100 items)		
Beam diagram(mm)			

※1 The cable doesn't come as standard.

※2 The maximum power consumption when a rejector is connected.

※3 8points can be added with an option.



Discover Precision

A&D Company, Ltd.

3-23-14 Higashi-Ikebukuro, Toshima-Ku, Tokyo, 170-0013, Japan Tel: +81 3-5391-6132 Fax: +81 3-5391-1566 <http://www.aandd.jp>

A&D Engineering, Inc.

1756 Automation Parkway, San Jose, CA 95131, U.S.A. Tel: +1 408-263-5333 Fax: +1 408-263-0119

A&D Australasia Pty Ltd.

32 Dew Street, Thebarton, South Australia 5031, Australia Tel: +61 8-8301-8100 Fax: +61 8-8352-7409

A&D Instruments Ltd.

Unit 24/26 Blacklands Way, Abingdon Business Park, Abingdon, Oxfordshire, OX14 1DY, United Kingdom Tel: +44 1235-550420 Fax: +44 1235-550485

<German Sales Office>

Hamburger Straße 30, D-22926, Ahrensburg, Germany Tel: +49 4102-459230 Fax: +49 4102-459231

A&D Korea Ltd.

8F Manhattan Bldg., 33, Gukjegeumyung-ro 6-gil, Yeongdeungpo-gu, Seoul, 07331, Korea Tel: +82 2-780-4101 Fax: +82 2-782-4280

A&D Rus Co., Ltd.

Vereyskaya Str. 17, 121357, Moscow, Russia Tel: +7 495-937-33-44 Fax: +7 495-937-55-66

A&D Instruments India (P) Ltd.

509 Udyog Vihar Phase V Gurgaon-122 016, Haryana, India Tel: +91 (124) 471-5555 Fax: +91 (124) 471-5599